

# XC9301/9302 Series



PWM, PWM/PFM Switching Step-Up & Down DC/DC Converter Controller ICs

- ◆ Input Voltage Range : 2.0V ~ 10.0V
- ◆ Output Voltage Range : 2.4V ~ 6.0V ( $\pm 2.5\%$  accuracy)
- ◆ Oscillation Frequency Range : 180kHz, 300kHz ( $\pm 15\%$  accuracy)
- ◆ Maximum Duty Ratio : 85% (typ)
- ◆ PWM/PFM Switching Step-Up & Down Control (XC9302)
- ◆ Efficiency : 81% (typ) 5.0V , 78% (typ) 3.3V
- ◆ SOT-25 Package

## Applications

- Mobile phones
- PDAs
- Palmtop computers
- Portable audio equipment
- Various power supplies

## General Description

The XC9301/02 series are step-up/down DC/DC converter controller ICs with fast, low ON resistance drivers built-in. A versatile, large output current, step-up/down DC/DC converter can be realised using only 4 basic external components - transistors, coils, diodes and capacitors.

Output voltage is selectable in 0.1V steps within a 2.4V ~ 6.0V ( $\pm 2.5\%$  accuracy) range and switching frequency is set at 180kHz or 300kHz.

The XC9302 series switches from PWM to PFM control during light loads and the series offers high efficiencies from light loads through to large output currents.

Soft-start time is internally set to 10 msec which offers protection against rush currents when the power is switched on and also against voltage overshoot.

During shutdown (CE pin = L), consumption current can be reduced to as little as 0.5 $\mu$ A or less.

## Features

- Input Voltage Range : 2.0V ~ 10V
- Output Voltage Range : 2.4V ~ 6.0V ( $\pm 2.5\%$  accuracy) (selectable in 0.1V steps)
- Oscillation Frequency : 180kHz, 300kHz ( $\pm 15\%$  accuracy)
- Output Current : more than 250mA ( $V_{IN}=2.4V$ ,  $V_{OUT}=3.3V$ )
- Efficiency : 81% (typ) at 5.0V, 78% (typ) at 3.3V
- Stand-By :  $I_{STB} = 0.5\mu A$  (max)
- Output Voltage Internal Set-Up
- SOT-25 Package

## Typical Application Circuit

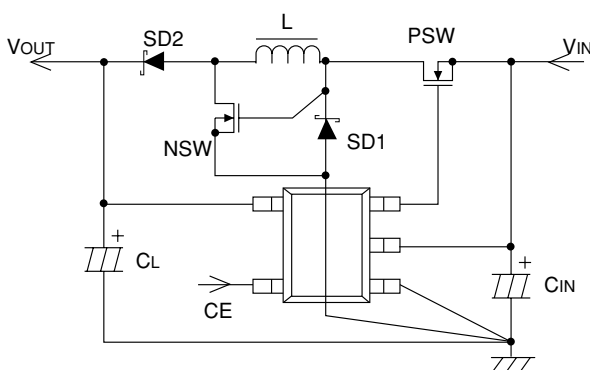

## Typical Performance Characteristic

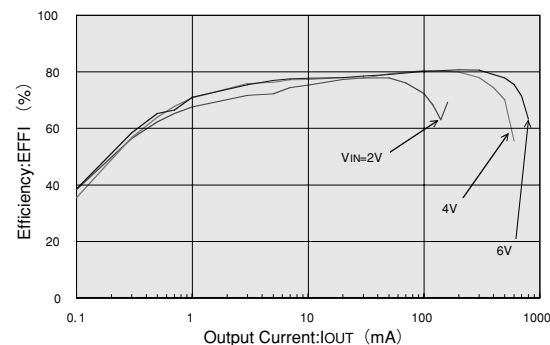

## Pin Configuration

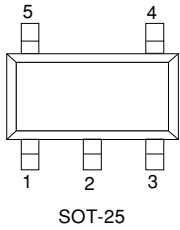

## Pin Assignment

PIN NUMBER	PIN NAME	FUNCTION
1	GND	Ground
2	VDD	Power Supply
3	EXT/	External Tr. Drive
4	VOUT	Output Voltage Monitor
5	CE	Chip Enable

## Product Classification

### Ordering Information

XC9301 ①②③④⑤⑥

XC9301 Series PWM control

DESIGNATOR	SYMBOL	DESCRIPTION
①	A	Standard (5-pin)
②		Output Voltage
③		e.g. V <sub>OUT</sub> =3.0V→②=3, ③=0, V <sub>OUT</sub> =5.3V→②=5, ③=3
④		Oscillation Frequency:
	2	180kHz
	3	300kHz
⑤	M	Package: SOT-25
⑥	R	Embossed Tape: Standard
	L	Reverse

XC9302 ①②③④⑤⑥

XC9302 Series PWM/PFM switching control (same as XC9302 Series)

## Packaging Information

### SOT-25

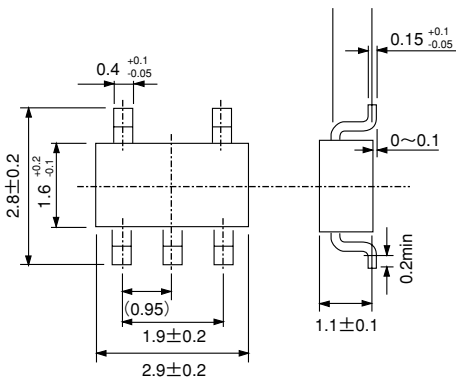

## Marking

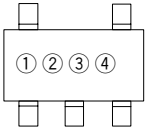

SOT-25  
(TOP VIEW)

① Represents the Product Classification

DESIGNATOR	PRODUCT NAME
<u>A</u>	XC9301A* * *M*
<u>K</u>	XC9302A* * *M*

② Represents the integer of the Output Voltage and Oscillation Frequency

OUTPUT VOLTAGE (V)	DESIGNATOR	
	FREQUENCY=180kHz (XC9301/XC9302A* * *2M*)	FREQUENCY=300kHz (XC9301/XC9302A* * *3M*)
2.X	<u>2</u>	<u>2</u>
3.X	<u>3</u>	<u>3</u>
4.X	<u>4</u>	<u>4</u>
5.X	<u>5</u>	<u>5</u>
6.X	<u>6</u>	<u>6</u>

③ Represents the decimal number of the Output Voltage and Oscillation Frequency

OUTPUT VOLTAGE (V)	DESIGNATOR	
	FREQUENCY=180kHz (XC9301/XC9302A* * *2M*)	FREQUENCY=300kHz (XC9301/XC9302A* * *3M*)
X.0	<u>0</u>	<u>A</u>
X.1	<u>1</u>	<u>B</u>
X.2	<u>2</u>	<u>C</u>
X.3	<u>3</u>	<u>D</u>
X.4	<u>4</u>	<u>E</u>
X.5	<u>5</u>	<u>F</u>
X.6	<u>6</u>	<u>H</u>
X.7	<u>7</u>	<u>K</u>
X.8	<u>8</u>	<u>L</u>
X.9	<u>9</u>	<u>M</u>

④ Denotes the production lot number  
0 to 9, A to Z repeated(G.I.J.O.Q.W excepted)

## Block Diagram

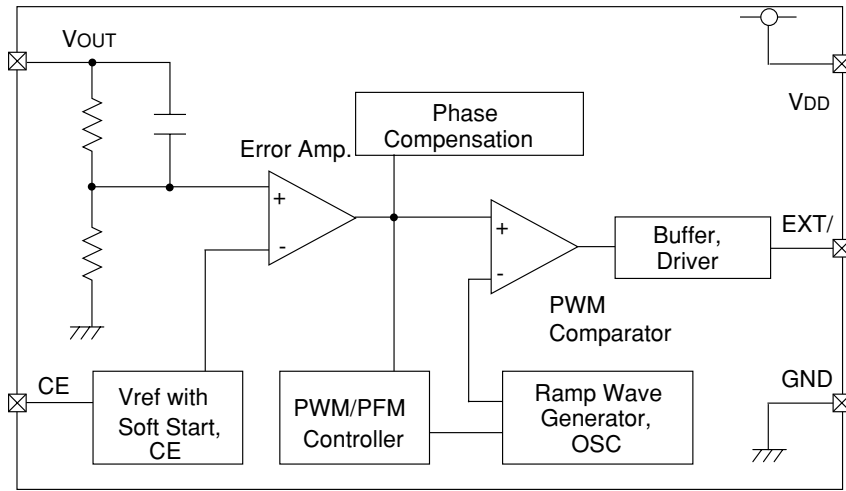

## 6

## Absolute Maximum Ratings

Ta = 25°C

PARAMETER	SYMBOL	RATINGS	UNITS
VDD Pin Voltage	VDD	-0.3~12	V
VOUT Pin Voltage	VOUT	-0.3~12	V
CE Pin Voltage	VCE	-0.3~12	V
EXT / Pin Voltage	VEXT/	-0.3~VDD+0.3	V
EXT / Pin Current	I EXT/	±100	mA
Power Dissipation	Pd	150	mW
Operating Ambient Temp.	Topr	-40~+85	°C
Storage Temp.	Tstg	-40~+125	°C

## Electrical Characteristics

XC9301x332MR, XC9302x332MR

(V<sub>OUT</sub>=3.3V, F<sub>OSC</sub>=180kHz)

T<sub>a</sub>=25°C

PARAMETER	SYMBOL	CONDITIONS	MIN.	TYP.	MAX.	UNITS
Output Voltage	V <sub>OUT</sub>		3.218	3.300	3.383	V
Supply Voltage	V <sub>DD</sub>		2.0	-	10.0	V
Supply Current 1	I <sub>DD1</sub>	V <sub>OUT</sub> =CE: Set Output Voltage × 0.95 applied	-	80	140	μA
Supply Current 2	I <sub>DD2</sub>	V <sub>OUT</sub> =CE: Set Output Voltage + 0.5 applied	-	15	26	μA
Stand-By Current	I <sub>STB</sub>	V <sub>OUT</sub> : Set Output Voltage × 0.95 applied, CE=0V	-	-	0.5	μA
Oscillation Frequency	F <sub>OSC</sub>	V <sub>DD</sub> =V <sub>OUT</sub> =CE: Set Output Voltage × 0.95 applied	153	180	207	KHz
Max. Duty Ratio	MAXDTY	V <sub>DD</sub> =V <sub>OUT</sub> =CE: Set Output Voltage × 0.95 applied	78	85	92	%
PFM Duty Ratio <sup>Note1</sup>	PFMDTY	No Load	15	25	35	%
Efficiency <sup>Note2</sup>	EFFI	V <sub>DD</sub> =V <sub>IN</sub> =CE: Set Output Voltage × 0.95 applied	-	78	-	%
Soft-Start Time	T <sub>SS</sub>		5.0	10.0	20.0	mS
CE 'H' Voltage	V <sub>CEH</sub>	V <sub>OUT</sub> : Set Output Voltage × 0.95 applied	0.65	-	-	V
CE 'L' Voltage	V <sub>CEL</sub>	V <sub>OUT</sub> : Set Output Voltage × 0.95 applied	-	-	0.20	V
EXT/ 'H' ON Resistance	R <sub>EXTBH</sub>	Same as I <sub>DD1</sub> , V <sub>EXT/</sub> = V <sub>OUT</sub> - 0.4V	-	29	43	Ω
EXT/ 'L' ON Resistance	R <sub>EXTBL</sub>	Same as I <sub>DD1</sub> , V <sub>EXT/</sub> = 0.4V	-	19	27	Ω

Measuring Conditions : Unless otherwise stated, V<sub>DD</sub> = 3.3V, I<sub>OUT</sub> = 130mA

Note: 1. XC9302 series only

2. EFFI=([(Output Voltage) × (Output Current)] ÷ [(Input Voltage) × (Input Current)]) × 100

XC9301x333MR, XC9302x333MR

(V<sub>OUT</sub>=3.3V, F<sub>OSC</sub>=300kHz)

T<sub>a</sub>=25°C

PARAMETER	SYMBOL	CONDITIONS	MIN.	TYP.	MAX.	UNITS
Output Voltage	V <sub>OUT</sub>		3.218	3.300	3.383	V
Supply Voltage	V <sub>DD</sub>		2.0	-	10.0	V
Supply Current 1	I <sub>DD1</sub>	V <sub>OUT</sub> =CE: Set Output Voltage × 0.95 applied	-	130	200	μA
Supply Current 2	I <sub>DD2</sub>	V <sub>OUT</sub> =CE: Set Output Voltage + 0.5 applied	-	20	35	μA
Stand-By Current	I <sub>STB</sub>	V <sub>OUT</sub> : Set Output Voltage × 0.95 applied, CE=0V	-	-	0.5	μA
Oscillation Frequency	F <sub>OSC</sub>	V <sub>DD</sub> =V <sub>OUT</sub> =CE: Set Output Voltage × 0.95 applied	255	300	345	KHz
Max. Duty Ratio	MAXDTY	V <sub>DD</sub> =V <sub>OUT</sub> =CE: Set Output Voltage × 0.95 applied	78	85	92	%
PFM Duty Ratio <sup>Note1</sup>	PFMDTY	No Load	15	25	35	%
Efficiency <sup>Note2</sup>	EFFI	V <sub>DD</sub> =V <sub>IN</sub> =CE: Set Output Voltage × 0.95 applied	-	78	-	%
Soft-Start Time	T <sub>SS</sub>		5.0	10.0	20.0	mS
CE 'H' Voltage	V <sub>CEH</sub>	V <sub>OUT</sub> : Set Output Voltage × 0.95 applied	0.65	-	-	V
CE 'L' Voltage	V <sub>CEL</sub>	V <sub>OUT</sub> : Set Output Voltage × 0.95 applied	-	-	0.20	V
EXT/ 'H' ON Resistance	R <sub>EXTBH</sub>	Same as I <sub>DD1</sub> , V <sub>EXT/</sub> = V <sub>OUT</sub> - 0.4V	-	29	43	Ω
EXT/ 'L' ON Resistance	R <sub>EXTBL</sub>	Same as I <sub>DD1</sub> , V <sub>EXT/</sub> = 0.4V	-	19	27	Ω

Measuring Conditions : Unless otherwise stated, V<sub>DD</sub> = 3.3V, I<sub>OUT</sub> = 130mA

Note: 1. XC9302 series only

2. EFFI=([(Output Voltage) × (Output Current)] ÷ [(Input Voltage) × (Input Current)]) × 100

## Typical Application Circuit

### ●Circuit Connection Example

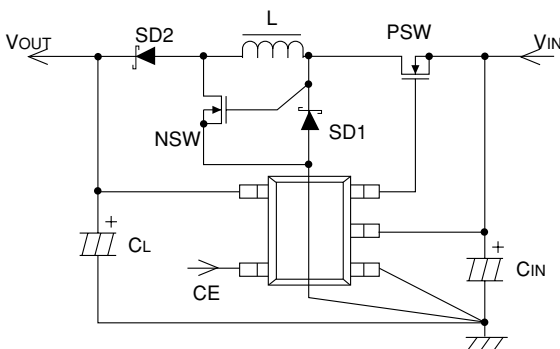

#### External Components

PSW : XP162A12 ( SOT-89 pkg, Torex )

NSW : XP161A12 ( SOT-89 pkg, Torex )

L : 22 μH ( Sumida CR54 )

SD : U2FWJ44N ( Schottky, Toshiba )

CL : 16V, 47 μF × 2 ( Tantalum, Nichicon MCE )

CIN : 16V, 220 μF ( Tantalum, Nichicon MCE )  
220 μF ( Nichicon, PJ )

## Operational Explanation

<Circuit Connection Example>

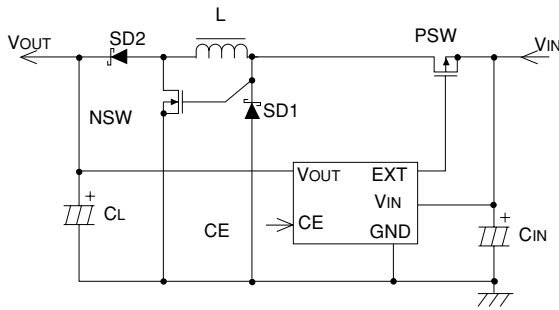

<Block Diagram>

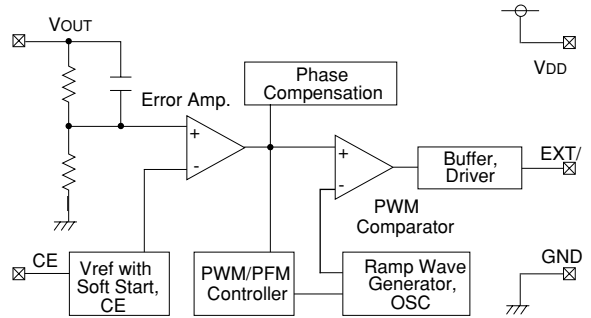

The XC9301/9302 series are PWM (PWM/PFM switching) step-up/down DC/DC converter controller ICs. The XC9302 series switches to PFM operations during light loads and is very efficient over a wide range in relation to load. Further, the efficiency can be maintained over a wide input voltage range as both step-up & step-down operations are PWM controlled. Output voltage settings are laser trimmed.

[ON TIME]

P-Ch MOSFET (PSW) = ON, N-Ch MOSFET (NSW) = ON : Current flows from  $V_{IN}$  via PSW, L, NSW, to GND : L is charged.

[OFF TIME]

P-Ch MOSFET (PSW) = OFF, N-Ch MOSFET (NSW) = OFF : Current flows from GND via SD1, L, SD2, to  $V_{OUT}$  :  $V_{OUT}$  rises due to the charge stored at L.

By comparing  $V_{OUT}$  with the internal reference voltage, the ON TIME vs OFF TIME ratio can be regulated & output stability can be protected.

### Block Diagram Explanation

<Error Amp.>

The error amplifier is used as an output voltage monitor. It compares the reference voltage with the feedback from the voltage divided by the internal resistor. Should a voltage higher than the reference voltage be feedback, the output of the error amp will increase.

<PWM Comparator>

The PWM comparator compares the output of the error amp with the ramp wave. When the voltage at the output of the error amp is low, the EXT/ pin will be LOW level (Switching ON time).

<Ramp Wave Generator>

The ramp wave generator, as the name suggests, generates the switching frequency's ramp wave.

<PWM / PFM Controller>

With the XC9302 series, control is automatically switched between PWM and PFM according to the size of the load.

<Vref with Soft Start, CE>

The start up of the Vref voltage at the error amp's input is gradual due to the internal capacitor and low current circuit. Because of this *soft-start* function, the operations of the error amp's 2 inputs are balanced and the EXT/ pin's ON time can be manipulated to produce longer ON times. Further, with the UVLO function, the signal will be such so as not to turn the MOS switch ON until any instability in the internal circuit stabilizes during soft-start time. Even in cases where input voltage is so low as to produce instability in the IC, the UVLO function will operate and the MOS switch will be turned OFF.

●Product Selection (Notes)

XC9301/02 series is a group of PFM controlled (XC9302 series switches from PWM to PFM control during light loads) step-up and down DC/DC converters. The series is highly efficient with a wide range of input voltage since its stepping-up and down operation is controlled by PWM movements. In general, there are several methods available for obtaining a stable output voltage at such times when input voltage is changing from being higher than the established output voltage to being lower than the established output voltage. Each method has its merits and demerits but is essential that a method which provides the best results in terms of input & output under actual operating conditions. Below, two methods are highlighted and their respective performances in terms of efficiency are compared.

This is an efficiency comparison of two ways, step-up DC/DC converter + VR and step-up & down DC/DC converter.

[Step-up DC/DC Converter + VR] (XC6361/62)

- ◆ Step-up mode (Input voltage < set output voltage + 0.4V)

After input voltage has been stepped-up to set output voltage + 0.4V by the step-up DC/DC converter, the output voltage will be regulated to the set value by the VR. (0.4V loss via the VR)

- ◆ Step-down mode (Input voltage ≥ set output voltage + 0.4V)

After input voltage has been stepped-up to set output voltage + 0.4V by the step-up DC/DC converter, the output voltage will be regulated to the set value by the VR. (Input/Output voltage difference loss via the VR)

[Step-up&down DC/DC Converter] (XC9301/02)

- ◆ Set output voltage obtained as a result of the automatic switching operations of the IC regardless of the difference between input voltage and set output voltage.

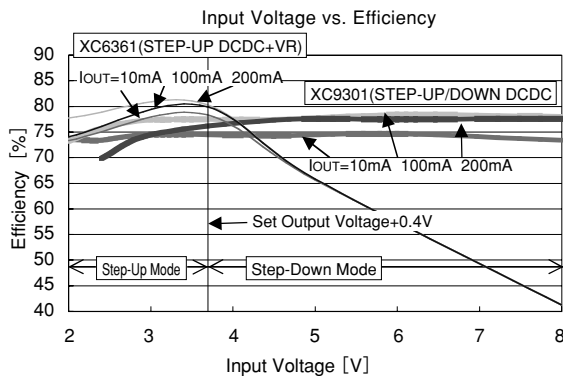

The above graph shows that over a wide input voltage range, the efficiency of the XC9301/02 is more or less constant. On the other hand, the efficiency of the XC6361/62 is clearly shown to decrease as input voltage increases. In step-down mode in particular, the efficiency of the XC9301/02 is much better than the XC6361/62. In applications that use either a standard dry 3 cell battery or a 2 cell lithium Ion battery to obtain an output of 3.3V, for example, the efficiency of the XC9301/02 series is again much better. Because the XC9301/02 series does not have a series regulator output, we recommend a test with samples for use in applications where ripple voltage is a problem.

●External Components Selection (Notes)

- The performance of the DC/DC converter IC circuit is heavily reliant upon the performance of the surrounding circuitry and components. In particular, since the VF voltage of the Schottky Diode used will have a direct effect upon efficiency, the smaller the diode, the better the efficiency obtainable. (Refer to the graph below)
- It is also recommended that a switching MOSFET with a small ON resistance be used. With the XC9301/02, an ON resistance of 500mΩ or less is recommended.

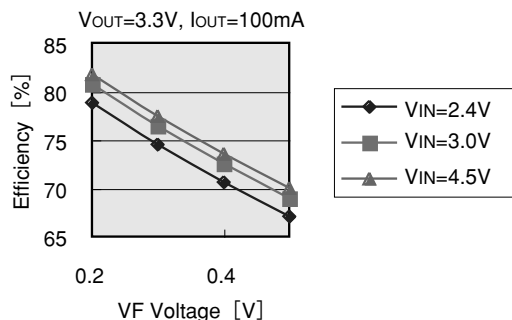

● Demo Board ver. 1.1

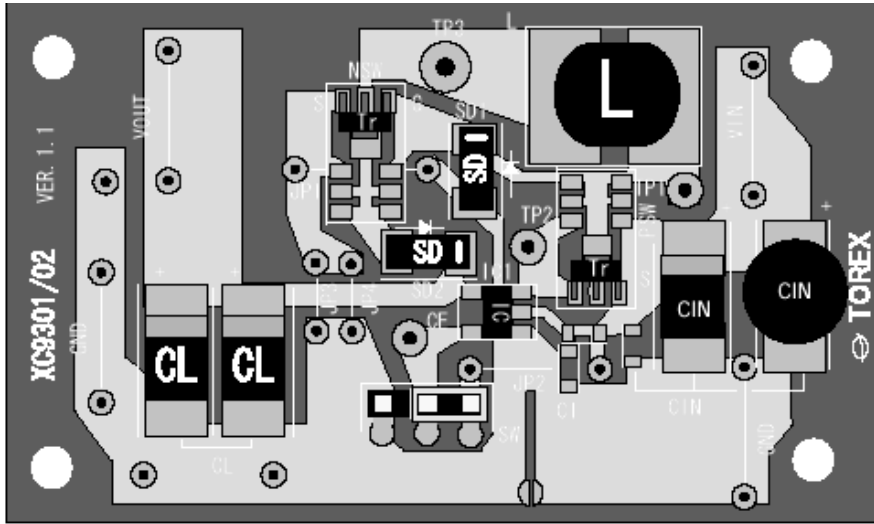

External Components

PSW : XP162A12(SOT-89)  
NSW : XP161A12(SOT-89)

L : 22  $\mu$ H (SUMIDA CR54)

SD : U2FWJ44N (Schottky, Toshiba)

CL : 16V 47  $\mu$ F $\times$ 2 (Tantalum, Nichicon MCE)

CIN : 16V 22  $\mu$ F (Tantalum, Nichicon MCE)  
16V 220  $\mu$ F (Electrolytic, PJ type)

Demo Board Connection Layout

} → suitable for SOT-23, SOT-89, CPH-6

→ suitable for CR43~CR105

→ suitable for MA720, MA735, U2FWJ44N

→ suitable for 1005 type~D2 Package

<Jumper Settings>

JP3 : Must be connected

JP2 : To be connected if using SW (CE pin fixed to  $V_{IN}$ )

\* Use tinned copper wire for  $V_{IN}$  pin,  $V_{OUT}$  pin, GND pin, JP2, and JP3.

\* Connect test pins for TP1, TP2, TP3, and CE.

Note:

Oscillation may occur as a result of input voltage instability when the output current is large. At such times, we recommend that in place of the 220 $\mu$ F PJ type capacitor, you connect R1 & C1 as shown in the diagram below.

(In case of demo boards ver. 1.1, cut the pattern wire of R1 connecting point, then connect R1.)

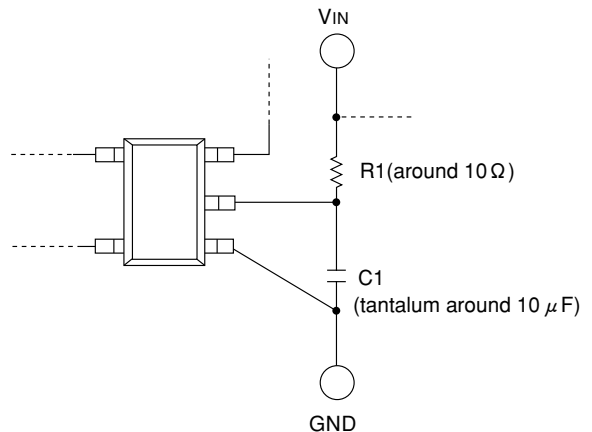



## Typical Performance Characteristics

XC9302A332 (PWM/PFM switching control, 180kHz,  $V_{OUT}=3.3V$ )

(1) OUTPUT VOLTAGE vs. OUTPUT CURRENT ( $T_{opr}=25^{\circ}C$ )

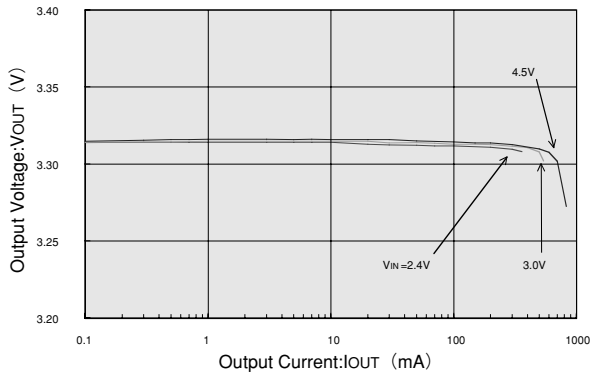

(2) EFFICIENCY vs. OUTPUT CURRENT ( $T_{opr}=25^{\circ}C$ )

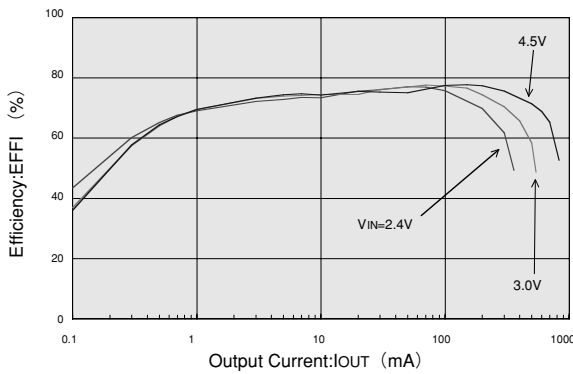

(3) RIPPLE VOLTAGE vs. OUTPUT CURRENT ( $T_{opr}=25^{\circ}C$ )

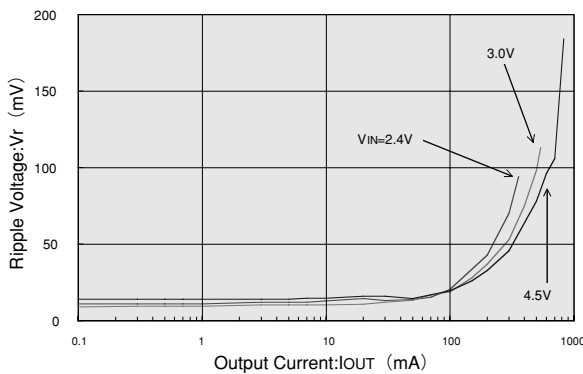

### External Components

PSW : XP162A12A6PR	CL : 47 $\mu$ F (Tantalum MCE) $\times$ 2
NSW : XP161A1265PR	CIN : 220 $\mu$ F (Electrolytic PJ type)
SD : U2FWJ44N $\times$ 2	R <sub>DD</sub> : 10 $\Omega$
L : 22 $\mu$ H (CR54)	C <sub>DD</sub> : 47 $\mu$ F (Tantalum MCE)
	V <sub>CE</sub> =V <sub>IN</sub>

## (4) LOAD TRANSIENT RESPONSE (T<sub>opr</sub>=25°C)

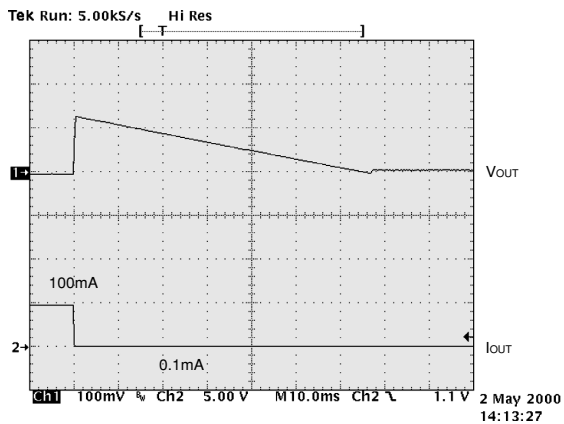
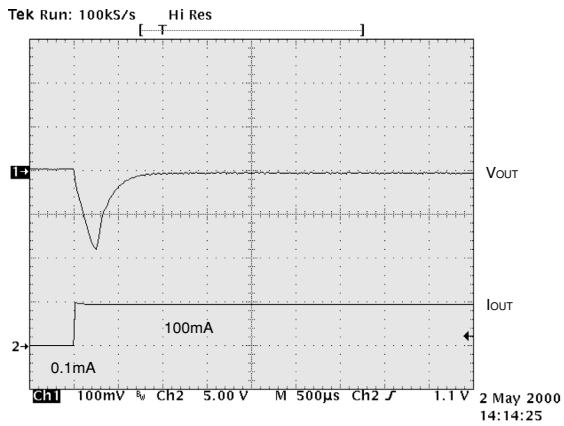

### External Components

PSW : XP162A12A6PR	C <sub>L</sub> : 47µF (Tantalum F93) ×2
NSW : XP161A1265PR	C <sub>IN</sub> : 220µF (Al. Electrolytic PJ type)
SD : U2FWJ44N ×2	R <sub>DD</sub> : 10Ω
L : 22µH (CR54)	C <sub>DD</sub> : 22µF (Tantalum)
	V <sub>CE</sub> =V <sub>IN</sub>

XC9302A502 (PWM/PFM switching control, 180kHz,  $V_{OUT}=5.0V$ )

(1) OUTPUT VOLTAGE vs. OUTPUT CURRENT ( $T_{opr}=25^{\circ}C$ )

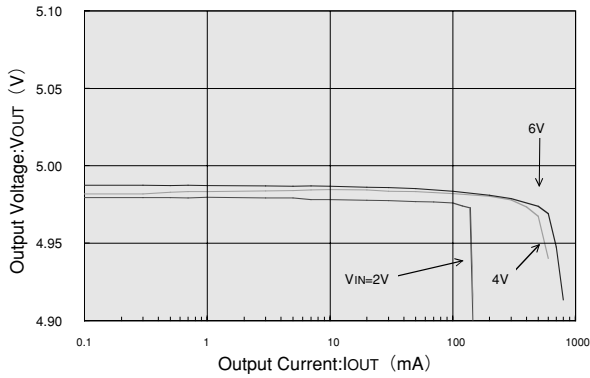

(2) EFFICIENCY vs. OUTPUT CURRENT ( $T_{opr}=25^{\circ}C$ )

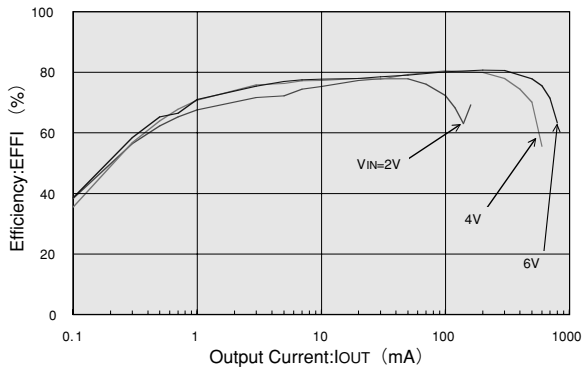

(3) RIPPLE VOLTAGE vs. OUTPUT CURRENT ( $T_{opr}=25^{\circ}C$ )

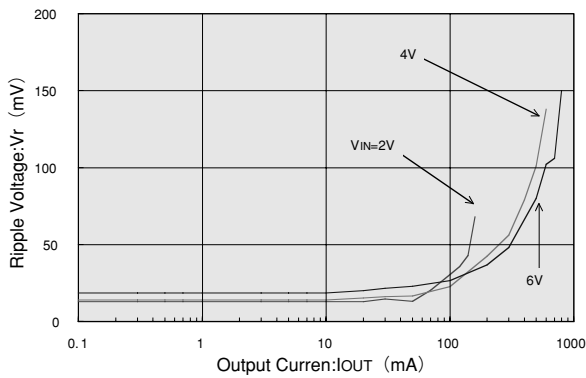

External Components

- |                          |   |
|--------------------------|---|
| PSW : XP162A12A6PR       | CL : 47 $\mu$ F (Tantalum MCE) $\times$ 2 |
| NSW : XP161A1265PR       | CIN : 220 $\mu$ F (Electrolytic PJ type)  |
| SD : U2FWJ44N $\times$ 2 | RDD : 10 $\Omega$                         |
| L : 22 $\mu$ H (CR54)    | CDD : 47 $\mu$ F (Tantalum MCE)           |
|                          | VCE=VIN                                   |

## (4) LOAD TRANSIENT RESPONSE (Topr=25°C)

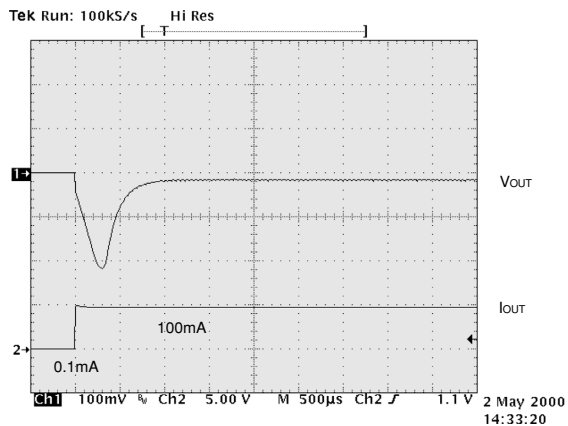

V<sub>IN</sub>=4.0V

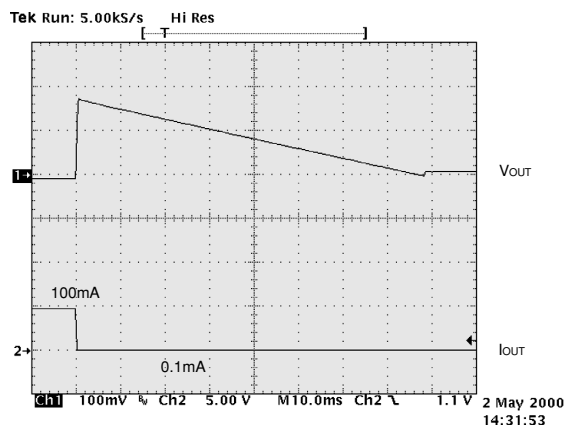

V<sub>IN</sub>=4.0V

### External Components

PSW : XP162A12A6PR	C <sub>L</sub> : 47µF (Tantalum F93) ×2
NSW : XP161A1265PR	C <sub>IN</sub> : 220µF (Electrolytic PJ type)
SD : U2FWJ44N	R <sub>DD</sub> : 10Ω
L : 22µH (CR54)	C <sub>DD</sub> : 47µF (Tantalum)
	V <sub>CE</sub> =V <sub>IN</sub>