

Features

- IDEAL FOR STORAGE APPLICATIONS
- COMPLEMENTARY DATA OUTPUTS
- COMMON CLOCK FOR SYNCHRONOUS OPERATION
- CLOCK ACTS AS ENABLE CONTROL WITH 1 UL
- PULLUP RESISTORS ON CHIP

General Description

The 370 contains four clocked D-type flip-flops with a common clock input acting as an enable line. Each stage has complementary outputs with passive pullup. Applications include quad latches and registers with parallel inputs and outputs.

Logic Diagram

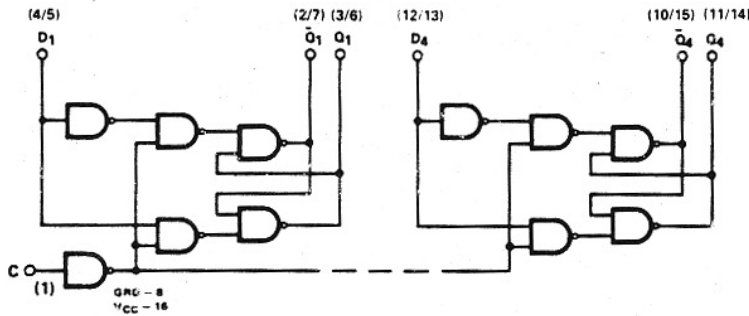

TRUTH TABLE

| C | D | Q^{n+1} |
|---|---|-------------|
| 1 | 1 | Q^n |
| 1 | 0 | \bar{Q}^n |
| 0 | 1 | 1 |
| 0 | 0 | 0 |

Equivalent Circuit

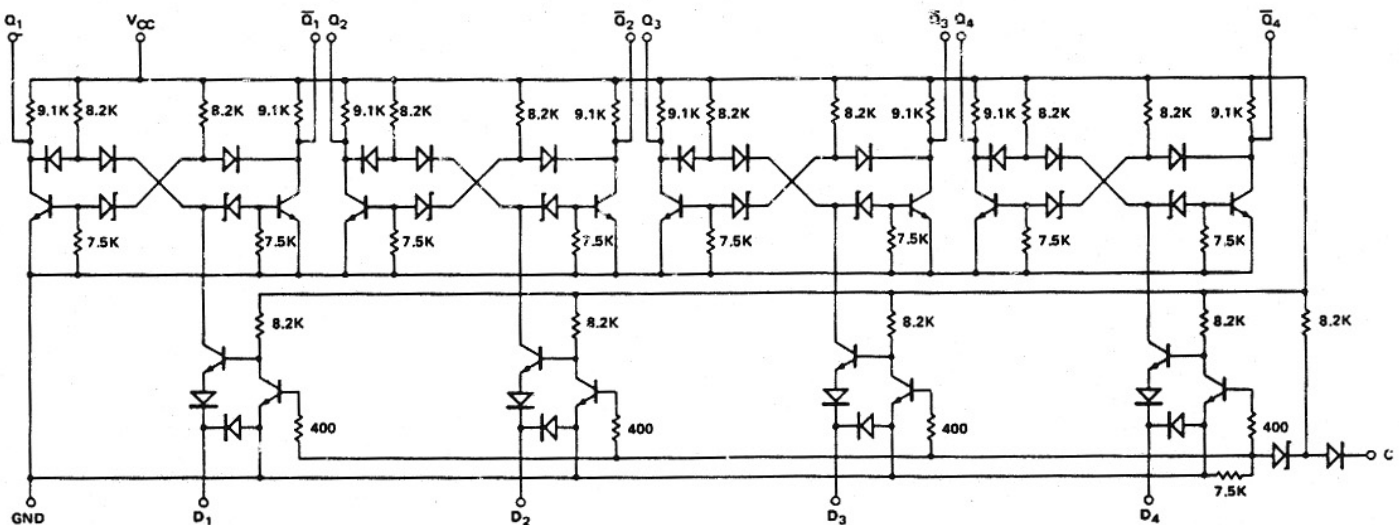

Key Specifications

| | | |
|---------------------------|--------------------------|--------|
| I_{CC} (WORST-CASE) | 38 mA @ 13V, 48 mA @ 16V | |
| t_{PD} | 750 ns | 750 ns |
| I/O FUNCTION FOR t_{PD} | C-Q+ | C-Q- |

Note: I_{CC} is tested at $V_{CC} + 1$ Volt (+13V for C type and +16V for A type) and is guaranteed across the applicable temp range. t_{PD} is guaranteed at $V_{CC} \pm 1V$ and across the applicable temp range with the output loaded with 4 unit loads.

See page 12 for electrical summary data.

Switching Time Waveforms

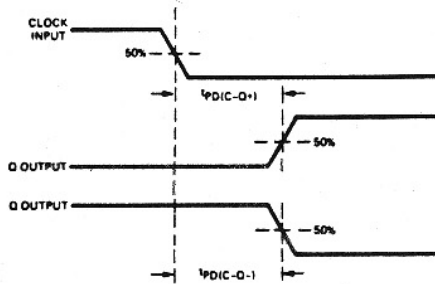

Loading Table

| PINS | FUNCTION | LOADING |
|--------------|-------------|---------|
| D | Data inputs | 2 UL |
| C | Clock input | 1 UL |
| Q, \bar{Q} | Outputs | 4 UL |

Typical Performance Characteristics

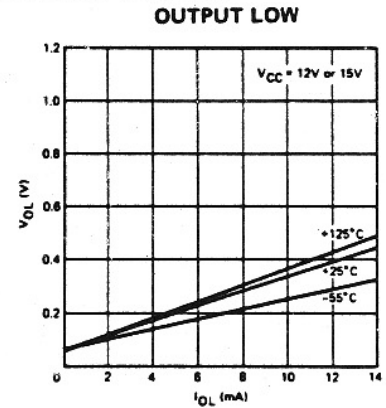
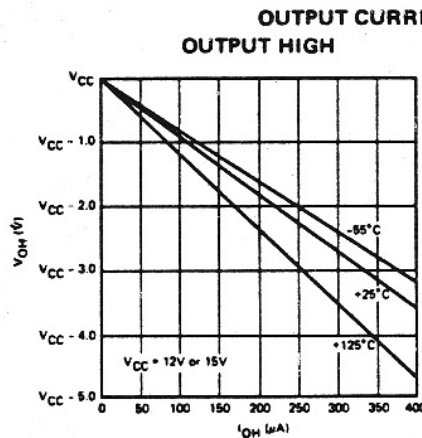
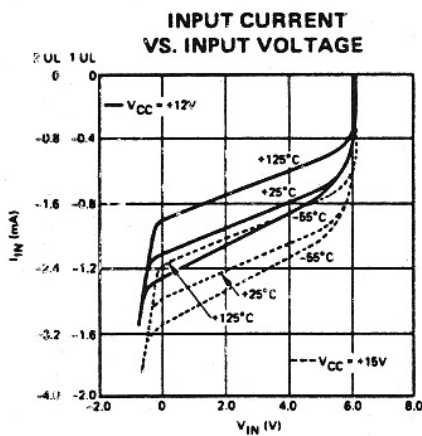

Typical Applications

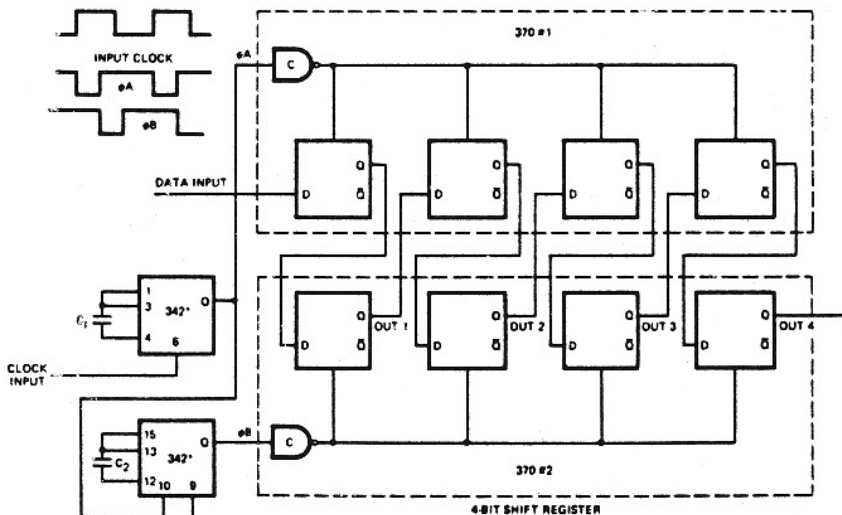

$1/2$ OF DUAL 342 ONE SHOT ELEMENT

Any number of 370 flip-flops may be connected to expand the shift register to any length. The 342 one-shots generate the two-phase clock signals.

Whenever the clock line is high, the flip-flops ignore the data on the D inputs, allowing the clock line to be used as a common input enable control. When the clock line is low, new data can enter the flip-flops and become available on the outputs, as shown by the truth table.