

**TAS1020A**  
**USB Streaming Controller**

*Data Manual*

## IMPORTANT NOTICE

Texas Instruments Incorporated and its subsidiaries (TI) reserve the right to make corrections, modifications, enhancements, improvements, and other changes to its products and services at any time and to discontinue any product or service without notice. Customers should obtain the latest relevant information before placing orders and should verify that such information is current and complete. All products are sold subject to TI's terms and conditions of sale supplied at the time of order acknowledgment.

TI warrants performance of its hardware products to the specifications applicable at the time of sale in accordance with TI's standard warranty. Testing and other quality control techniques are used to the extent TI deems necessary to support this warranty. Except where mandated by government requirements, testing of all parameters of each product is not necessarily performed.

TI assumes no liability for applications assistance or customer product design. Customers are responsible for their products and applications using TI components. To minimize the risks associated with customer products and applications, customers should provide adequate design and operating safeguards.

TI does not warrant or represent that any license, either express or implied, is granted under any TI patent right, copyright, mask work right, or other TI intellectual property right relating to any combination, machine, or process in which TI products or services are used. Information published by TI regarding third-party products or services does not constitute a license from TI to use such products or services or a warranty or endorsement thereof. Use of such information may require a license from a third party under the patents or other intellectual property of the third party, or a license from TI under the patents or other intellectual property of TI.

Reproduction of information in TI data books or data sheets is permissible only if reproduction is without alteration and is accompanied by all associated warranties, conditions, limitations, and notices. Reproduction of this information with alteration is an unfair and deceptive business practice. TI is not responsible or liable for such altered documentation.

Resale of TI products or services with statements different from or beyond the parameters stated by TI for that product or service voids all express and any implied warranties for the associated TI product or service and is an unfair and deceptive business practice. TI is not responsible or liable for any such statements.

### Mailing Address:

Texas Instruments  
Post Office Box 655303  
Dallas, Texas 75265

# Contents

<i>Section</i>	<i>Title</i>	<i>Page</i>
<b>1</b>	<b>Introduction</b>	<b>1–1</b>
1.1	Features	1–1
1.2	Functional Block Diagram	1–3
1.3	Terminal Assignments—Normal Mode	1–3
1.4	Terminal Assignments—External MCU Mode	1–4
1.5	Ordering Information	1–4
1.6	Terminal Functions—Normal Mode	1–5
1.7	Terminal Functions—External MCU Mode	1–6
1.8	Device Operation Modes	1–7
1.9	Terminal Assignments for Codec Port Interface Modes	1–7
<b>2</b>	<b>Description</b>	<b>2–1</b>
2.1	Architectural Overview	2–1
2.1.1	Oscillator and PLL	2–1
2.1.2	Clock Generator and Sequencer Logic	2–1
2.1.3	Adaptive Clock Generator (ACG)	2–1
2.1.4	USB Transceiver	2–1
2.1.5	USB Serial Interface Engine (SIE)	2–1
2.1.6	USB Buffer Manager (UBM)	2–2
2.1.7	USB Frame Timer	2–2
2.1.8	USB Suspend and Resume Logic	2–2
2.1.9	MCU Core	2–2
2.1.10	MCU Memory	2–2
2.1.11	USB Endpoint Configuration Blocks and Buffer Space	2–2
2.1.12	DMA Controller	2–2
2.1.13	Codec Port Interface	2–3
2.1.14	I <sup>2</sup> C Interface	2–3
2.1.15	General-Purpose IO Ports (GPIO)	2–3
2.1.16	Interrupt Logic	2–3
2.1.17	Reset Logic	2–3
2.2	Device Operation	2–3
2.2.1	Clock Generation	2–4
2.2.2	Boot Process	2–4
2.2.3	USB Enumeration	2–8
2.2.4	TAS1020A USB Reset Logic	2–9
2.2.5	USB Suspend and Resume Modes	2–10
2.2.6	Adaptive Clock Generator (ACG)	2–11
2.2.7	USB Transfers	2–14
2.2.8	Microcontroller Unit	2–24

2.2.9	External MCU Mode Operation .....	2–24
2.2.10	Interrupt Logic .....	2–24
2.2.11	General-Purpose I/O (GPIO) Ports .....	2–29
2.2.12	DMA Controller .....	2–32
2.2.13	Codec Port Interface .....	2–32
2.2.14	I <sup>2</sup> C Interface .....	2–43
<b>3</b>	<b>Electrical Specifications .....</b>	<b>3–1</b>
3.1	Absolute Maximum Ratings Over Operating Temperature Ranges .....	3–1
3.2	Recommended Operating Conditions .....	3–1
3.3	Electrical Characteristics Over Recommended Operating Conditions .....	3–1
3.4	Timing Characteristics .....	3–2
3.4.1	Clock and Control Signals Over Recommended Operating Conditions .....	3–2
3.4.2	USB Signals When Sourced by TAS1020A Over Recommended Operating Conditions .....	3–2
3.4.3	Codec Port Interface Signals (AC '97 Modes), T <sub>A</sub> = 25°C, DV <sub>DD</sub> = 3.3 V, AV <sub>DD</sub> = 3.3 V .....	3–3
3.4.4	Codec Port Interface Signals (I <sup>2</sup> S Modes) Over Recommended Operating Conditions .....	3–4
3.4.5	Codec Port Interface Signals (General-Purpose Mode) Over Recommended Operating Conditions .....	3–4
3.4.6	I <sup>2</sup> C Interface Signals Over Recommended Operating Conditions .....	3–5
<b>4</b>	<b>Application Information .....</b>	<b>4–1</b>
<b>A</b>	<b>MCU Memory and Memory-Mapped Registers .....</b>	<b>A–1</b>
A.1	MCU Memory Space .....	A–1
A.2	Internal Data Memory .....	A–2
A.3	External MCU Mode Memory Space .....	A–3
A.4	USB Endpoint Configuration Blocks and Data Buffer Space .....	A–4
A.4.1	USB Endpoint Configuration Blocks .....	A–4
A.4.2	Data Buffer Space .....	A–4
A.4.3	USB OUT Endpoint Configuration Bytes .....	A–9
A.4.4	USB IN Endpoint Configuration Bytes .....	A–12
A.4.5	USB Control Endpoint Setup Stage Data Packet Buffer ..	A–15
A.5	Memory-Mapped Registers .....	A–16
A.5.1	USB Registers .....	A–18
A.5.2	DMA Registers .....	A–21
A.5.3	Adaptive Clock Generator Registers .....	A–25
A.5.4	Codec Port Interface Registers .....	A–28
A.5.5	P3 Mask Register .....	A–38
A.5.6	I <sup>2</sup> C Interface Registers .....	A–38
A.5.7	Miscellaneous Registers .....	A–41
<b>B</b>	<b>Mechanical Data .....</b>	<b>B–1</b>

## List of Illustrations

<i>Figure</i>	<i>Title</i>	<i>Page</i>
2-1	Adaptive Clock Generator .....	2-12
2-2	TAS1020A Interrupt, Reset, Suspend, and Resume Logic .....	2-25
2-3	Activation of Setup Stage Transaction Overwrite Interrupt .....	2-27
2-4	GPIO Port 1 and Port 3 Functionality .....	2-30
2-5	Codec Port Interface Parameters – AC '97 1.0 .....	2-35
2-6	Codec Port Interface Parameters – AIC .....	2-36
2-7	Codec Port Interface Parameters – I <sup>2</sup> S .....	2-38
2-8	Byte Reversal Example .....	2-39
2-9	Connection of the TAS1020A to an AC '97 Codec .....	2-40
2-10	Connection of the TAS1020A to Multiple AC '97 Codecs .....	2-41
2-11	Bit Transfer on the I <sup>2</sup> C Bus .....	2-44
2-12	I <sup>2</sup> C START and STOP Conditions .....	2-44
2-13	TAS1020A Acknowledge on the I <sup>2</sup> C Bus .....	2-45
2-14	Single Byte Write Transfer .....	2-45
2-15	Multiple Byte Write Transfer .....	2-45
2-16	Single Byte Read Transfer .....	2-46
2-17	Multiple Byte Read Transfer .....	2-46
3-1	External Interrupt Timing Waveform .....	3-2
3-2	USB Differential Driver Timing Waveform .....	3-2
3-3	BIT_CLK and SYNC Timing Waveforms .....	3-3
3-4	SYNC, SD_IN, and SD_OUT Timing Waveforms .....	3-3
3-5	I <sup>2</sup> S Mode Timing Waveforms .....	3-4
3-6	General-Purpose Mode Timing Waveforms .....	3-4
3-7	SCL and SDA Timing Waveforms .....	3-5
3-8	Start and Stop Conditions Timing Waveforms .....	3-5
3-9	Acknowledge Timing Waveform .....	3-5
4-1	Typical TAS1020A Device Connections .....	4-1
A-1	Boot Loader Mode Memory Map .....	A-2
A-2	Normal Operating Mode Memory Map .....	A-3
A-3	USB Endpoint Configuration Blocks and Buffer Space Memory Map .....	A-5

## List of Tables

<i>Table</i>	<i>Title</i>	<i>Page</i>
2-1	EEPROM Header .....	2-6
2-2	ACG Frequency Registers .....	2-13
2-3	Terminal Assignments for Codec Port Interface General-Purpose Mode ..	2-33
2-4	Terminal Assignments for Codec Port Interface AC '97 1.0 Mode .....	2-39
2-5	Terminal Assignments for Codec Port Interface AC '97 2.0 Mode .....	2-40
2-6	Terminal Assignments for Codec Port Interface I2S Modes .....	2-41
2-7	SLOT Assignments for Codec Port Interface I <sup>2</sup> S Mode 4 .....	2-42
2-8	SLOT Assignments for Codec Port Interface I <sup>2</sup> S Mode 5 .....	2-42
2-9	Terminal Assignments for Codec Port Interface AIC Mode .....	2-43
A-1	USB Endpoint Configuration Blocks Address Map .....	A-6
A-2	USB Control Endpoint Setup Data Packet Buffer Address Map .....	A-15
A-3	Memory-Mapped Registers Address Map .....	A-16

# 1 Introduction

The TAS1020A integrated circuit (IC) is a universal serial bus (USB) peripheral interface device designed specifically for applications that require isochronous data streaming. Applications include digital speakers, which require the streaming of digital audio data between the host PC and the speaker system via the USB connection. The TAS1020A device is fully compatible with the USB Specification Version 1.1 and the USB Audio Class Specification.

The TAS1020A uses a standard 8052 microcontroller unit (MCU) core with on-chip memory. The MCU memory includes 8K bytes of program memory ROM that contains a boot loader program. At initialization, the boot loader program downloads the application program code to a 6,016-byte RAM from either the host PC or a nonvolatile memory on the printed-circuit board (PCB). The MCU handles all USB control, interrupt and bulk endpoint transactions. DMA channels are provided to handle isochronous endpoint transactions.

The USB interface includes an integrated transceiver that supports 12 Mb/s (full speed) data transfers. In addition to the USB control endpoint, support is provided for up to seven IN endpoints and seven OUT endpoints. The USB endpoints are fully configurable by the MCU application code using a set of endpoint configuration blocks that reside in on-chip RAM. All USB data transfer types are supported.

The TAS1020A device also includes a codec port interface (C-Port) that can be configured to support several industry standard serial interface protocols. These protocols include the audio codec (AC) '97 Revision 1.X, the audio codec (AC) '97 Revision 2.X and several inter-IC sound (I<sup>2</sup>S) modes.

A direct memory access (DMA) controller with two channels is provided for streaming the USB isochronous data packets to/from the codec port interface. Each DMA channel can support one USB isochronous endpoint.

An on-chip phase lock loop (PLL) and adaptive clock generator (ACG) provide support for the USB synchronization modes, which include asynchronous, synchronous and adaptive.

Other on-chip MCU peripherals include an inter-IC control (I<sup>2</sup>C) serial interface, and two 8-bit general-purpose input/output (GPIO) ports.

The TAS1020A device is implemented in a 3.3-V 0.25  $\mu$ m CMOS technology.

## 1.1 Features

- **Universal Serial Bus (USB)**
  - USB specification version 1.1 compatible
  - USB audio class specification 1.0 compatible
  - Integrated USB transceiver
  - Supports 12 Mb/s data rate (full speed)
  - Supports suspend/resume and remote wake-up
  - Supports control, interrupt, bulk, and isochronous data transfer types
  - Supports up to a total of seven IN endpoints and seven OUT endpoints in addition to the control endpoint
  - Data transfer type, data buffer size, single or double buffering is programmable for each endpoint
  - On-chip adaptive clock generator (ACG) supports asynchronous, synchronous and adaptive synchronization modes for isochronous endpoints
  - To support synchronization for streaming USB audio data, the ACG can be used to generate the master clock for the codec

- **Micro-Controller Unit (MCU)**
  - Standard 8052 8-bit core
  - 8K bytes of program memory ROM that contains a boot loader program and a library of commonly used USB functions
  - 6016 bytes of program memory RAM which is loaded by the boot loader program
  - 256 bytes of internal data memory RAM
  - Two GPIO ports
  - MCU handles all USB control, interrupt, and bulk endpoint transfers
- **DMA Controller**
  - Two DMA channels to support streaming USB audio data to/from the codec port interface
  - Each channel can support a single USB isochronous endpoint
  - In the I<sup>2</sup>S mode the device can support DAC/ADCs at different sampling frequencies
  - A circular programmable FIFO used for isochronous audio data streaming
- **Codec Port Interface**
  - Configurable to support AC'97 1.X, AC'97 2.X, AIC or I<sup>2</sup>S serial interface formats
  - I<sup>2</sup>S modes can support a combination of one DAC and/or two ADCs
  - Can be configured as a general-purpose serial interface
  - Can support bulk data transfer using DMA for higher throughput
- **I<sup>2</sup>C Interface**
  - Master only interface
  - Does not support a multimaster bus environment
  - Programmable to 100 kb/s or 400 kb/s data transfer speeds
  - Supports wait states to accommodate slow slaves
- **General Characteristics**
  - High performance 48-pin TQFP Package
  - On-chip phase-locked loop (PLL) with internal oscillator is used to generate internal clocks from a 6 MHz crystal input
  - Reset output available which is asserted for both system and USB reset
  - External MCU mode supports application firmware development
  - 8K ROM with boot loader program and commonly used USB functions library
  - 3.3 V core and I/O buffers



## 1.2 Functional Block Diagram

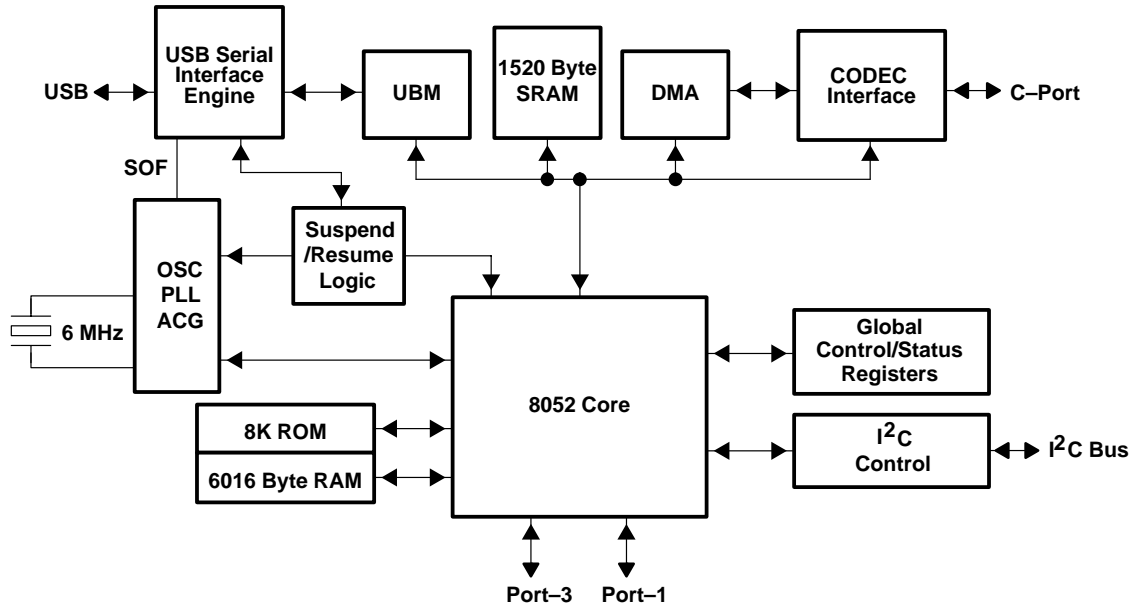

## 1.3 Terminal Assignments—Normal Mode

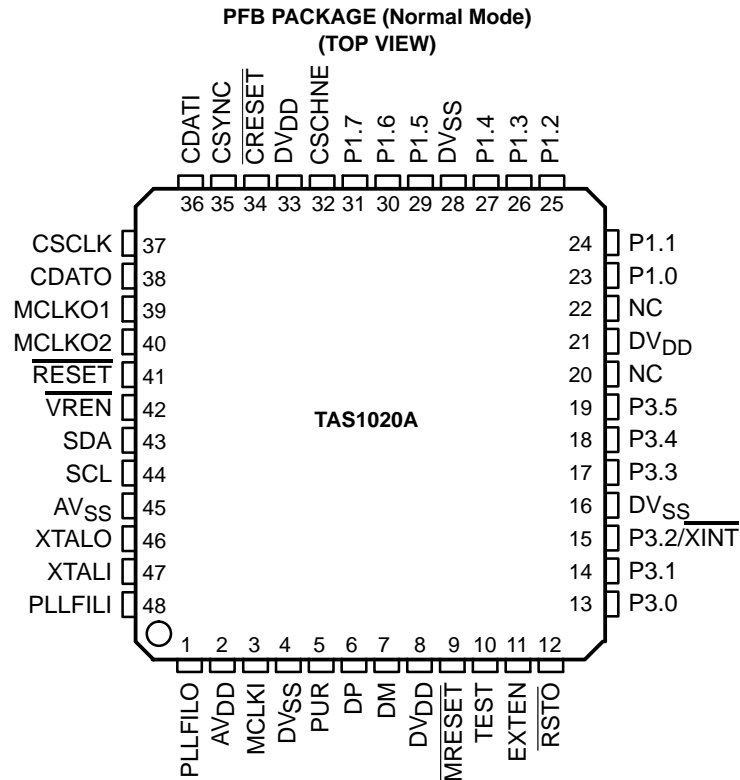

## 1.4 Terminal Assignments—External MCU Mode

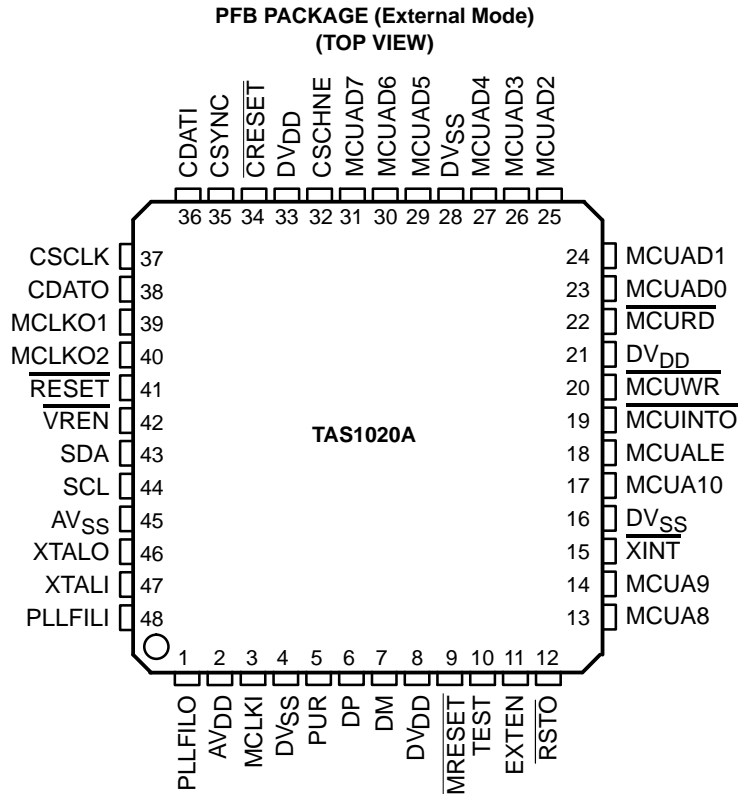

## 1.5 Ordering Information

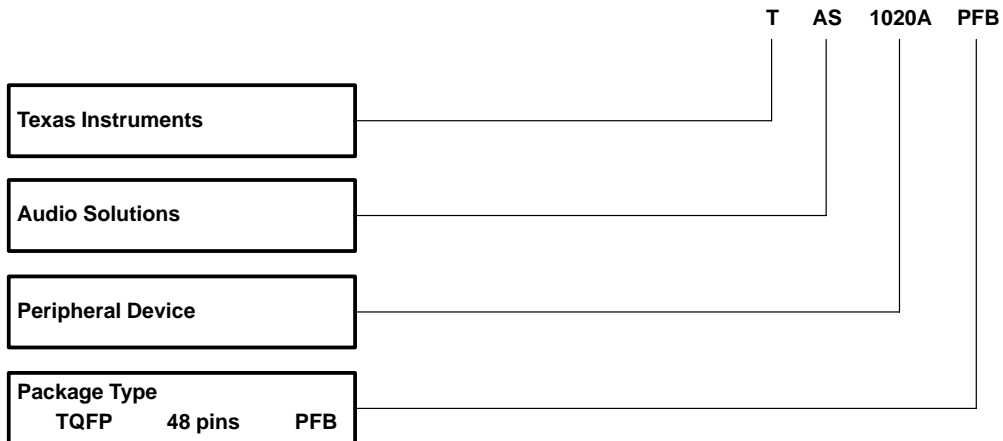

## 1.6 Terminal Functions—Normal Mode

TERMINAL			I/O	DESCRIPTION
NAME	PIN TYPE	NO.		
AV <sub>DD</sub>	Power	2		3.3-V analog supply voltage
AV <sub>SS</sub>	Power	45		Analog ground
CCLK	CMOS	37	I/O	Codec port interface serial clock: CCLK is the serial clock for the codec port interface used to clock the CSYNC, CDATO, CDATI, $\overline{\text{CRESET}}$ , AND CSCHNE signals.
CSYNC	CMOS	35	I/O	Codec port interface frame sync: CSYNC is the frame synchronization signal for the codec port interface.
CDATO	CMOS	38	I/O	Codec port interface serial data out
CDATI	CMOS	36	I/O	Codec port interface serial data in
$\overline{\text{CRESET}}$	CMOS	34	I/O	Codec port interface reset output
CSCHNE	CMOS	32	I/O	Codec port interface secondary channel enable
DP	CMOS	6	I/O	USB differential pair data signal plus. DP is the positive signal of the bidirectional USB differential pair used to connect the TAS1020A device to the universal serial bus.
DM	CMOS	7	I/O	USB differential pair data signal minus. DM is the negative signal of the bidirectional USB differential pair used to connect the TAS1020A device to the universal serial bus.
DV <sub>DD</sub>	Power	8, 21, 33		3.3-V digital supply voltage
DV <sub>SS</sub>	Power	4, 16, 28		Digital ground
EXTEN	CMOS	11	I	External MCU mode enable: Input used to enable the device for the external MCU mode
MCLKI	CMOS	3	I	Master clock input. An input that can be used as the master clock for the codec port interface or the source for MCLKO2.
MCLKO1	CMOS	39	O	Master clock output 1: The output of the ACG that can be used as the master clock for the codec port interface and the codec.
MCLKO2	CMOS	40	O	Master clock output 2: An output that can be used as the master clock for the codec port interface and the codec used in I <sup>2</sup> S modes for receive. This clock signal can also be used as a miscellaneous clock.
$\overline{\text{MRESET}}$	CMOS	9	I	Master reset: An active low asynchronous reset for the device that resets all logic to the default state
NC		20,22		Not used
P1.[0:7]	CMOS	23, 24, 25, 26, 27, 29, 30, 31	I/O	General-purpose I/O port [bits 0 through 1]: A bidirectional 8-bit I/O port with an internal 100 $\mu\text{A}$ active pullup
P3.[0:6]	CMOS	13, 14, 15, 17, 18, 19	I/O	General-purpose I/O port [bits 0 through 1]: A bidirectional I/O port with an internal 100 $\mu\text{A}$ active pullup
PLLFILO	CMOS	48	I	PLL loop filter input: Input to on-chip PLL from external filter components
PLLFILO	CMOS	1	O	PLL loop filter output: Output from on-chip PLL to external filter components
PUR	CMOS	5	O	USB data signal plus pullup resistor connect. PUR is used to connect the pullup resistor on the DP signal from a high-impedance state to 3.3 V. When the DP signal is connected to 3.3-V the host PC detects the connection of the TAS1020A device to the universal serial bus.
$\overline{\text{RESET}}$	CMOS	41	O	General-purpose active-low output which is memory mapped
$\overline{\text{RSTO}}$	CMOS	12	O	Reset output: An output that is active while the master reset input or the USB reset is active
SCL	CMOS	44	O	I <sup>2</sup> C interface serial clock
SDA	CMOS	43	I/O	I <sup>2</sup> C interface serial data
TEST	CMOS	10	I	Test mode enable: Factory test mode
$\overline{\text{VREN}}$	CMOS	42	O	General-purpose active-low output which is memory mapped
XINT	CMOS	15	I	External interrupt: An active low input used by external circuitry to interrupt the on-chip 8052 MCU
XTALI	CMOS	47	I	Crystal input: Input to the on-chip oscillator from an external 6-MHz crystal
XTALO	CMOS	46	O	Crystal Output: Output from the on-chip oscillator to an external 6-MHz crystal

## 1.7 Terminal Functions—External MCU Mode

TERMINAL			I/O	DESCRIPTION
NAME	PIN TYPE	NO.		
AVDD	Power	2	–	3.3-V Analog supply voltage
AVSS	Power	45	–	Analog ground
CSCLK	CMOS	37	I/O	Codec port interface serial clock: CSCLK is the serial clock for the codec port interface used to clock the CSYNC, CDATO, CDATI, <u>CRESET</u> AND CSCHNE signals.
CSYNC	CMOS	35	I/O	Codec port interface frame sync: CSYNC is the frame synchronization signal for the codec port interface.
CDATO	CMOS	38	I/O	Codec port interface serial data output
CDATI	CMOS	36	I/O	Codec port interface serial data input
<u>CRESET</u>	CMOS	34	I/O	Codec port interface reset output
CSCHNE	CMOS	32	I/O	Codec port interface secondary channel enable
DP	CMOS	6	I/O	USB differential pair data signal plus: DP is the positive signal of the bidirectional USB differential pair used to connect the TAS1020A device to the universal serial bus.
DM	CMOS	7	I/O	USB differential pair data signal minus. DM is the negative signal of the bidirectional USB differential pair used to connect the TAS1020A device to the universal serial bus.
DVDD	Power	8, 21, 33	–	3.3-V Digital supply voltage
DVSS	Power	4, 16, 28	–	Digital ground
EXTEN	CMOS	11	I	External MCU mode enable: Input used to enable the device for the external MCU mode. This signal uses a 3.3 V TTL/LVCMOS input buffer.
MCLKI	CMOS	3	I	Master clock input: An input that can be used as the master clock for the codec port interface or the source for MCLKO2.
MCLKO1	CMOS	39	O	Master clock output 1: The output of the ACG that can be used as the master clock for the codec port interface and the codec.
MCLKO2	CMOS	40	O	Master clock output 2: An output that can be used as the master clock for the codec port interface and the codec. This clock signal can also be used as a miscellaneous clock.
<u>MRESET</u>	CMOS	9	I	Master reset: An active low asynchronous reset for the device that resets all logic to the default state.
MCUAD [0:7]	CMOS	23, 24, 25, 26, 27, 29, 30, 31	I/O	MCU multiplexed address/data: Multiplexed address bits[0:7]/data bits[0:7] for external MCU access to the TAS1020A external data memory space.
MCUA [8:10]	CMOS	13, 14, 17	I/O	MCU address bus: Multiplexed address bus bits[8:10] for external MCU access to the TAS1020A external data memory space.
MCUALE	CMOS	18	I	MCU address latch enable: Address latch enable for external MCU access to the TAS1020A external data memory space.
<u>MCUINTO</u>	CMOS	19	O	MCU interrupt output: Interrupt output to be used for external MCU <u>INTO</u> input signal. All internal TAS1020A interrupt sources are read together to generate this output signal.
<u>MCUWR</u>	CMOS	20	I	MCU write strobe: Write strobe for external MCU write access to the TAS1020A external data memory space.
<u>MCURD</u>	CMOS	22	I	MCU read strobe: Read strobe for external MCU read access to the TAS1020A external data memory space.
PLLFILO	CMOS	48	I	PLL loop filter input: Input to on-chip PLL from external filter components.
PLLFILO	CMOS	1	O	PLL loop filter output: Output to on-chip PLL from external filter components.
PUR	CMOS	5	O	USB data signal plus pullup resistor connect. PUR is used to connect the pullup resistor on the DP signal to 3.3V from a high-impedance state. When the DP signal is connected in a 3.3-V state, the host PC should detect the connection of the TAS1020A device to the universal serial bus.
<u>RESET</u>	CMOS	41	O	General-purpose active-low output which is memory mapped
<u>RSTO</u>	CMOS	12	O	Reset output: An output that is active while the master reset input or the USB reset is active.
SCL	CMOS	44	O	I <sup>2</sup> C interface serial clock
SDA	CMOS	43	I/O	I <sup>2</sup> C interface serial data input/output
TEST	CMOS	10	I	Test mode enable: Factory text mode

## 1.7 Terminal Functions—External MCU Mode (Continued)

TERMINAL			I/O	DESCRIPTION
NAME	PIN TYPE	NO.		
$\overline{\text{VREN}}$	CMOS	42	O	General-purpose active-low output which is memory mapped.
XINT	CMOS	15	I	External interrupt: An active low input used by external circuitry to interrupt the on-chip 8052 MCU.
XTALI	CMOS	47	I	Crystal input: Input to the on-chip oscillator from an external 6-MHz crystal.
XTALO	CMOS	46	O	Crystal output: Output from the on-chip oscillator to an external 6-MHz crystal.

## 1.8 Device Operation Modes

The EXTEN and TEST pins define the mode that the TAS1020A is in after reset.

MODE	EXTEN	TEST
Normal mode – internal MCU	0	0
External MCU mode	1	0
Factory test	0	1
Factory test	1	1

## 1.9 Terminal Assignments for Codec Port Interface Modes

The codec port interface has five modes of operation that support AC97, I<sup>2</sup>S, and AIC codecs. There is also a general-purpose mode that is not specific to a serial interface. The mode is programmed by writing to the mode select field of the codec port interface configuration register 1 (CPTCNF1). The codec port interface terminals CSYNC, CSCLK, CDATO, CDATI,  $\overline{\text{CRESET}}$ , and CSCHNE take on functionality appropriate to the mode programmed as shown in the following table.

TERMINAL		GP Mode 0		AIC Mode 1		AC '97 v1.X Mode 2		AC '97 v2.X Mode 3		I <sup>2</sup> S Mode 4		I <sup>2</sup> S Mode 5	
NO.	NAME		I/O										
35	CSYNC	CSYNC	I/O	$\overline{\text{FS}}$	O	SYNC	O	SYNC	O	LRCK	O	LRCK1	O
37	CSCLK	CSCLK	I/O	SCLK	O	BIT_CLK	I	BIT_CLK	I	SCLK	O	SCLK1	O
38	CDATO	CDATO	O	DOUT	O	SD_OUT	O	SD_OUT	O	SDOUT1	O	SDOUT1	O
36	CDATI	CDATI	I	DIN	I	SD_IN	I	SD_IN1	I	SDIN1	I	SDIN2	I
34	$\overline{\text{CRESET}}$	$\overline{\text{CRESET}}$	O	$\overline{\text{RESET}}$	O	$\overline{\text{RESET}}$	O	$\overline{\text{RESET}}$	O	$\overline{\text{CRESET}}$	O	SCLK2	O
32	CSCHNE	NC	O	FC	O	NC	O	SD_IN2	I	SDIN2	I	LRCK2	O

- NOTES:
1. Signal names and I/O direction are with respect to the TAS1020A device. The signal names used for the TAS1020A terminals for the various codec port interface modes reflect the nomenclature used by the codec devices.
  2. NC indicates no connection for the terminal in a particular mode. The TAS1020A device drives the signal as an output for these cases.
  3. The CSYNC and CSCLK signals can be programmed as either an input or an output in the general-purpose mode.



## 2 Description

### 2.1 Architectural Overview

#### 2.1.1 Oscillator and PLL

Using an external 6-MHz crystal, the TAS1020A derives the fundamental 48-MHz internal clock signal using an on-chip oscillator and PLL. Using the PLL output, the other required clock signals are generated by the clock generator and adaptive clock generator.

#### 2.1.2 Clock Generator and Sequencer Logic

Utilizing the 48-MHz output from the PLL, the clock generator logic generates all internal clock signals, except for the codec port interface master clock (MCLK) and serial clock (CSCLK) signals. The TAS1020A internal clocks include the 48-MHz clock, a 24-MHz clock, and a 12-MHz clock. A 12 MHz USB clock is also generated. The USB clock is the same as the internal 12-MHz clock when the TAS1020A is transmitting data, but is derived from the data when the TAS1020A is receiving data. To derive the USB clock when receiving USB data, the TAS1020A utilizes an internal digital PLL (DPLL) driven from the 48-MHz clock.

The sequencer logic controls the access to the SRAM used for the USB endpoint configuration blocks and the USB endpoint buffer space. The SRAM can be accessed by the MCU, the USB buffer manager (UBM), or the DMA channels. The sequencer controls the access to the memory using a round-robin fixed priority arbitration scheme. This means that the sequencer logic generates grant signals for the MCU, UBM, and DMA channels at a predetermined fixed frequency.

#### 2.1.3 Adaptive Clock Generator (ACG)

The adaptive clock generator is used to generate a master clock output signal (MCLKO) to be used by the codec port interface and the codec device. To synchronize data sent to or received from the codec to the USB frame rate, the MCLKO signal generated by the adaptive clock generator must be used. The synchronization of the MCLKO signal to the USB frame rate is achieved by the ACG, which, in turn, is controlled by a soft PLL, implemented in the MCU. One of the tasks performed by the ACG is to maintain count of the number of MCLKO clocks between USB Start of Frame (SOF) events. This count is monitored by the soft PLL in the MCU. Based on this count, the soft PLL outputs corrections to the ACG to adjust MCLKO to obtain the correct number of MCLKO clocks between USB SOF events.

MCLKI, the master clock input, can also be selected to source the clocks used by the codec port interface. When MCLKI is selected, it is used to derive the TAS1020A-sourced versions of the clocks CSCLK and CSYNC. In this scenario, the codec device would also use the same master clock signal (MCLKI).

#### 2.1.4 USB Transceiver

The TAS1020A provides an integrated transceiver for the USB port. The transceiver includes a differential output driver, a differential input receiver, and two single ended input buffers. The transceiver connects to the USB DP and DM signal terminals.

#### 2.1.5 USB Serial Interface Engine (SIE)

The serial interface engine logic manages the USB packet protocol for packets being received and transmitted by the TAS1020A. For packets being received, the SIE decodes the packet identifier field (PID) to determine the type of packet being received and to ensure the PID is valid. The SIE then calculates the cycle redundancy check (CRC) of the received token and data packets and compares the value to the CRC contained in the packet to verify that the packet was not corrupted during transmission. For transmitted token and data packets, the SIE generates the CRC that is transmitted with the packet. The SIE also generates the synchronization field (SYNC) and the correct PID for all transmitted packets. Another major function of the SIE is the serial-to-parallel conversion of received data packets and the parallel-to-serial conversion of transmitted data packets.

### **2.1.6 USB Buffer Manager (UBM)**

The USB buffer manager provides the control logic that interfaces the SIE to the USB endpoint buffers. One of the major functions of the UBM is to decode the USB function address to determine if the host PC is addressing the TAS1020A device USB peripheral function. In addition, the endpoint address field and direction signal are decoded to determine which particular USB endpoint is being addressed. Based on the direction of the USB transaction and the endpoint number, the UBM will either write or read the data packet to or from the appropriate USB endpoint data buffer.

### **2.1.7 USB Frame Timer**

The USB frame timer logic receives the start of frame (SOF) packet from the host PC each USB frame. Each frame, the logic stores the 11-bit frame number value from the SOF packet in a register and asserts the internal SOF signal. The frame number register can be read by the MCU and the value can be used as a time stamp. For USB frames in which the SOF packet is corrupted or not received, the frame timer logic will generate a pseudo start of frame (PSOF) signal and increment the frame number register.

### **2.1.8 USB Suspend and Resume Logic**

The USB suspend and resume logic detects suspend and resume conditions on the USB. This logic also provides the internal signals used to control the TAS1020A device when these conditions occur. The capability to resume operation from a suspend condition with a locally generated remote wake-up event is also provided.

### **2.1.9 MCU Core**

The TAS1020A uses an 8-bit microcontroller core that is based on the industry standard 8052. The MCU is software compatible with the 8052, 8032, 80C52, 80C53, and 87C52 MCUs. The 8052 MCU is the processing core of the TAS1020A and handles all USB control, interrupt and bulk endpoint transfers. Bulk out end-point transfers can also be handled by one of the two DMA channels.

### **2.1.10 MCU Memory**

In accordance with the industry standard 8052, the TAS1020A MCU memory is organized into program memory, external data memory and internal data memory. A boot ROM program is used to download the application code to a 6K byte RAM that is mapped to the program memory space. The external data memory includes the USB endpoint configuration blocks, USB data buffers, and memory mapped registers. The total external data memory space available is 1.5K bytes. A total of 256 bytes are provided for the internal data memory.

### **2.1.11 USB Endpoint Configuration Blocks and Buffer Space**

The USB endpoint configuration blocks are used by the MCU to configure and operate the required USB endpoints for a particular application. In addition to the control end-point, the TAS1020A supports a total of seven IN endpoints and seven OUT endpoints. A set of six bytes is provided for each endpoint to specify the endpoint type, buffer address, buffer size, and data packet byte count.

The USB endpoint buffer configuration blocks and buffer space provided totals 1440 bytes. The buffer space to be used by a particular endpoint is fully configurable by the MCU for a particular application. Therefore, the MCU can configure each buffer based on the total number of endpoints to be used, the maximum packet size to be used for each endpoint, and the selection of single or double buffering.

### **2.1.12 DMA Controller**

Two DMA channels are provided to support the streaming of data for USB isochronous IN endpoints, isochronous OUT endpoints, and bulk OUT endpoints. Each DMA channel can support one USB isochronous IN endpoint, or one isochronous OUT endpoint, or one bulk OUT endpoint. The DMA channels are used to stream data between the USB



endpoint data buffers and the codec port interface. The USB endpoint number and direction can be programmed for each DMA channel. Also, the codec port interface time slots to be serviced by each DMA channel can be programmed.

### 2.1.13 Codec Port Interface

The TAS1020A provides a configurable full duplex bidirectional serial interface that can be used to connect to a codec or other external device types for streaming USB isochronous data. The interface can be configured to support several different industry standard protocols, including AC '97 1.X, AC '97 2.X, AIC, and I<sup>2</sup>S. The TAS1020A also has a general-purpose mode to support other protocols.

### 2.1.14 I<sup>2</sup>C Interface

The I<sup>2</sup>C interface logic provides a two-wire serial interface that the 8052 MCU can use to access other ICs. The TAS1020A is an I<sup>2</sup>C master device only and supports single byte or multiple byte read and write operations. The interface can be programmed to operate at either 100 kbps or 400 kbps. In addition, the protocol supports 8-bit or 16-bit addressing for accessing the I<sup>2</sup>C slave device memory locations. The TAS1020A supports I<sup>2</sup>C wait states. This means slaves can assert wait state on the I<sup>2</sup>C bus by pulling the SCL line low.

### 2.1.15 General-Purpose IO Ports (GPIO)

The TAS1020A provides two general-purpose IO ports that are controlled by the internal 8052 MCU. The two ports are port 1 and port 3. Port 1 provides true GPIO capability. Each bit of port 1 can be independently used as either an input or output, and consists of an output buffer, an input buffer, and a pullup resistor. Some of the bits of port 3 also provide true GPIO capability, but, in addition, some of the bits of port 3 also provide alternate input and output uses. An example of this is P3.2, which is used as the external interrupt ( $\overline{XINT}$ ) input to the TAS1020A. A detailed description of the alternate uses of some of the port 3 bits is presented in Section 2.2.11.

The pullup resistors for port 1 and port 3 can be disabled by bits P1PUDIS and P3PUDIS respectively in the on-chip register GLOBCTL. In addition, any port 3 pin can be used to wake up the host PC from a low-power suspend mode.

### 2.1.16 Interrupt Logic

The interrupt logic monitors the various conditions that can cause an interrupt and asserts the interrupt 0 (INT0) input on the 8052 MCU core accordingly. All of the TAS1020A internal interrupt sources and the external interrupt ( $\overline{XINT}$ ) input are ORed together to generate the INT0 signal. An interrupt vector register is used by the MCU to identify the interrupt source.

### 2.1.17 Reset Logic

An external master reset ( $\overline{MRESET}$ ) input signal that is asynchronous to the internal clocks can be used to reset the TAS1020A logic. In addition to this master reset, the TAS1020A logic can also be reset by a USB reset from the host PC if bit FRSTE in the on-chip register USBCTL is set to 1. The TAS1020A also provides a reset output ( $\overline{RSTO}$ ) signal that can be used by external devices. This signal is asserted when either a master reset occurs or when a USB reset occurs and FRSTE is set to 1.

## 2.2 Device Operation

The operation of the TAS1020A is explained in the following sections. For additional information on USB, refer to the Universal Serial Bus Specification, Version 1.1.

## 2.2.1 Clock Generation

The TAS1020A requires an external 6-MHz crystal with load capacitors and PLL loop filter components to derive all the clocks needed for both USB and codec operation. Figure 4–1 shows the connection of these components to the TAS1020A. Figure 4–1 also shows a ground shield residing on the top layer of the PCB and underneath the crystal and its load capacitors and the PLL components. The PLL is an analog PLL, and noise pickup in these components can translate to phase jitter at the output of the PLL, which in turn can translate to distortion at the codec. A ground shield is recommended to attenuate the digital noise components on the board as seen at the PLL.

The  $AV_{SS}$  and  $AV_{DD}$  pins on the TAS1020A are used exclusively to power the analog PLL. To maintain isolation from the digital noise residing on a board,  $AV_{SS}$  should be a separate ground plane that connects to the primary ground plane (DGND) at a single point via a ferrite bead. The ferrite bead should exhibit around  $9\ \Omega$  of impedance at 100 MHz.  $AV_{DD}$  should also be distinct from  $DV_{DD}$ . A recommended architecture is to generate  $DV_{DD}$  and  $AV_{DD}$  from the same regulator line, with each derived from a RC filter in series with the regulator output. It is finally recommended that the ground shield for the crystal and its load capacitors and the PLL loop filter components be connected to  $AV_{SS}$  at a single point via a ferrite bead of the same type as above.

Using the low frequency 6-MHz crystal and generating the required higher frequency clocks internally in the TAS1020A is a major advantage with regard to EMI.

## 2.2.2 Boot Process

The TAS1020A can boot from EEPROM or execute a host boot. Host boot will be used in the following circumstances:

- No EEPROM is present.
- An EEPROM is present, but does not contain a valid header.
- An EEPROM is present, but is a device EEPROM (contains header information only).

### 2.2.2.1 EEPROM Boot Process

If the target device has an application EEPROM (an EEPROM that contains both header and application data), and if the header portion of the EEPROM content is valid, the EEPROM application code is downloaded to on-chip RAM. During the download process, the RAM is mapped to data space, and the boot code that orchestrates the download is part of the on-chip firmware housed in on-chip ROM. Also, while the application code is being downloaded, the TAS1020A remains disconnected from the USB bus.

When the download is complete, the firmware sets the ROM disable bit SDW. The setting of this bit maps the RAM from data space to program space, starting address 0x0000. Having set bit SDW, the firmware then branches to address 0x0000, which is the reset entry point for the application code. The application code is now running.

The application code then switches on the PUR output. The PUR output pin is connected, through a resistor, to the positive (DP) line of the differential USB bus. Switching PUR on informs the host that a full speed (12 Mb/s) device is present on the bus. In the enumeration procedure that follows, the application code reports its run-time device descriptor set. Following enumeration, the device is actively running its application.

### 2.2.2.2 Host Boot Process

The DFU code in the TAS1020A fully adheres to the USB Device Class Specification for DFU 1.0. In addition, the TAS1020A utilizes the communication protocols from the DFU specification to implement a *host boot* capability for those applications that do not have an EEPROM resource. In such cases, the TAS1020A, at power-up, reports its DFU mode descriptor set rather than its run-time descriptor set and directly enters what the DFU specification terms the DFU Program Mode. The host processor must be cognizant of the fact that the device under enumeration does not have an EEPROM resource with valid code, and is already in the DFU mode awaiting a download per the DFU protocol. All of this capability is provided by the ROM-based code (firmware) that resides on the TAS1020A.

Specifically, the host boot process addresses three cases—an EPROM is not present, an EEPROM is present but the data in the EEPROM is invalid, or an EEPROM is present but the EEPROM is a device EEPROM (contains only

header data). In all three of these cases, the TAS1020A firmware comes up in the DFU Program Mode. A host boot ensues, but the final destination of the download depends on the status of the onboard EEPROM.

- If the firmware determines that no EEPROM is present (by noting, when addressing the EEPROM, the absence of an acknowledge from the EEPROM), a Vendor ID of 0xFFFF and a Product ID of 0xFFFE is reported during enumeration. The download that follows enumeration is written to the on-chip RAM. The download from the host must include a header (see Section 2.2.2.3.1), and the *header overwrite* bit in the header downloaded must be set to 0. (The *header overwrite* bit is used to instruct the TAS1020A firmware as to whether or not the header portion of the download is to be written into the EEPROM. Since, in this case, no EEPROM is present, this *header overwrite* bit must be set to 0). It is noted that the host must have prior knowledge that the target will initialize in the DFU program mode and will require a download of application code (and header) to RAM.
- If the firmware determines that an EEPROM is present (acknowledges are received from the EEPROM), but that the header data in the EEPROM is invalid, a Vendor ID of 0xFFFF and a Product ID of 0xFFFE is reported during enumeration. The download that follows enumeration is written to EEPROM. Since the EEPROM data was invalid, the host has to set the *header overwrite* bit in the header portion of the download to a 1 to ensure that the header is written to the EEPROM. It is noted that the host must have prior knowledge that the target does have an EEPROM, but that the data in the EEPROM is invalid. This could be a situation such as the initial download of the application on a production line.
- If the firmware determines that an EEPROM is present, that the header data in the EEPROM is valid, but that the header data in the EEPROM indicates that the EEPROM is a *device* EEPROM, the Vendor ID and Product ID settings in the EEPROM-resident header is reported during enumeration. In addition, the strings in the header, if applicable, are reported. The EEPROM download that follows enumeration will be written to the on-chip RAM facility. In addition to downloading the application code to RAM, an option also exists to download the header portion of the download image to the EEPROM. If the host does not wish to overwrite the valid header data in the EEPROM, it must set the *header overwrite* bit in its download header to a 0. It is noted that the host must have knowledge that the target contains an EEPROM, and that the EEPROM is a *device* EEPROM.

### 2.2.2.3 EEPROM Data Organization

Two types of data can be stored in the EEPROM—header data, which contains USB device information, and application code. The presence of header data in the EEPROM is mandatory, but the presence of application code is optional.

### 2.2.2.3.1 EEPROM Header

Table 2–1 shows the format and information contained in the header data. As seen from Table 2–1, the header data begins at address 0x0000 in the EEPROM and precedes the application code.

**Table 2–1. EEPROM Header**

OFFSET	TYPE	SIZE	VALUE
0	headerChecksum	1	Header check sum—derived by adding the header data, excluding the header checksum, in bytes, and retaining the lower byte of the sum as the checksum.
1	HeaderSize	1	Size, in units of bytes, of the header including strings if applied
2	Signature	2	Signature: 0x1234
4	VendorID	2	USB Vendor ID
6	ProductID	2	USB Product ID
8	ProductVersion	1	Product version
9	FirmwareVersion	1	Firmware version
10	UsbAttributes	1	USB attributes: Bit 0: If set to 1, the header includes all three strings: language, manufacture, and product strings, if set to 0, the header does not include any string. The strings, if present, must conform to the USB string format per USB spec 1.0 or later. Bit 1 : Not used. Bit 2: If set to 1, the device can be self powered, if set to 0, cannot be self powered. Bit 3: If set to 1, the device can be bus powered, if set to 0, cannot be bus powered. Bit 4 ... 7: Reserved
11	MaxPower	1	Maximum power the device needs in units of 2 mA.
12	Attributes	1	Device attributes: Bit 0: If set to 1, the CPU clock is 24 MHz, if set to 0, the CPU clock is 12 MHz. Bit 1: If set to 1, the download version of the header will be written into the EEPROM (download target has to be EEPROM). If the header is not to be overwritten, or if the target is RAM, this bit must be cleared to 0. Bit 2: Not used. Bit 3: If set to 1, the EEPROM can support a 400 kHz I <sup>2</sup> C bus, if set to 0, the EEPROM cannot support a 400 MHz I <sup>2</sup> C bus. Bit 4 ... 7: Reserved
13	WPageSize	1	Maximum I <sup>2</sup> C write page size, in units of bytes
14	DataType	1	This value defines if the device is an application EEPROM or a device EEPROM. 0x01: Application EEPROM—contains header and application code. 0x02: Device EEPROM—contains only header. All other values are invalid.
15	RpageSize	1	Maximum I <sup>2</sup> C read page size, in units of bytes. If the value is zero, the whole payloadSize is read in one I <sup>2</sup> C read setup.
16	payloadSize	2	Size, in units of bytes, of the application, if using EEPROM as an application EEPROM, otherwise the value is 0.
xxxx	Language string	4	Language string in standard USB string format if applied. If this attribute is applied, the two attributes that follow must also be applied. If this attribute is not applied, the following two attributes cannot be applied.
xxxx	Manufacture string	...	Manufacture string in standard USB string format if applied.
xxxx	Product string	...	Product string in standard USB string format if applied.
xxxx	Application Code	...	Application code if applied

The header checksum is used by the firmware to detect the presence of a valid header in the EEPROM. The header size field supports future updates of the header.

### 2.2.2.3.2 Application Code

Application code is stored as a binary image in the EEPROM following the header information. The binary image must always be mapped to MCU program space starting at address 0x0000, and must be stored in the EEPROM as a continuous linear block of data.

#### 2.2.2.4 I<sup>2</sup>C Serial EEPROM

The TAS1020A accesses the EEPROM via an I<sup>2</sup>C serial bus. Thus the EEPROM must be an I<sup>2</sup>C serial EEPROM. The ROM boot loader assumes the EEPROM device uses the full 7-bit I<sup>2</sup>C device address with the upper four bits of the address (control code) set to 1010 and the three least significant bits (chip select bits) set to 000.

#### 2.2.2.5 DFU Upgrade Process

DFU compliance provides a host the capability of upgrading application code currently residing in a target's onboard EEPROM memory. The DFU upgrade process provided by the TAS1020A fully conforms to the requirements specified in USB Device Class Specification For DFU 1.0.

The download must consist of both header and application code. The destination of the download must be defined by the on-chip application code (as opposed to the application code being downloaded). Under normal circumstances, the download destination would be EEPROM, but it is possible for the application code to specify on-chip RAM as the download destination.

If the download destination is to be EEPROM, bit 1 of the Attribute field in the header data being downloaded determines whether or not the header data in the download image is to be written to the EEPROM. A bit value of 1 results in the header in the EEPROM being overwritten by the header content in the download image. It is important to note that if the application code targets RAM as the download destination, bit 1 in the Attribute field of the download image must be 0.

#### 2.2.2.6 Download Error Recovery

Safeguards are incorporated on the TAS1020A ROM to allow recovery from a host download that does not complete due to a loss of power. Before downloading the application code, the TAS1020A saves the value of the Data Type field in the EEPROM header and modify the Data Type field to indicate that a download is in progress. After successful completion of the download, the TAS1020A restores the saved value in the Data Type field. If the download is terminated prior to successful completion, the Data Type field still indicates that a download is in progress. In the case of an unsuccessful download the TAS1020A reboots as a DFU device in DFU Program mode and uses the Vendor and Product ID from the EEPROM header as the vendor and product ID in its USB device descriptor.

The download process consists of the following task flow.

- Header portion of download is written to EEPROM, if applicable.
- Header Data Type is retrieved and stored in RAM.
- Head Data Type is overwritten with a value indicating that a download is in progress.
- Application portion of download is written to EEPROM (or to RAM).
- Header Data Type is overwritten with the previously recorded legal value.

If the download should terminate during the downloading of the header to EEPROM, the header checksum results in the EEPROM being declared invalid on the next boot of the TAS1020A. If the download should terminate during the downloading of the application code, the Data Type field indicates that a download was in progress and the TAS1020A enters the DFU program mode on the next boot.

If the TAS1020A remains powered when a premature termination of a download occurs, the TAS1020A remains in the DFU program mode. In this case, the host can again attempt a download; the TAS1020A does not have to be rebooted.

### 2.2.2.7 ROM Support Functions

In order to conserve RAM memory resources on the TAS1020A, several USB-specific routines have been included in the firmware resident in the on-chip ROM. The inclusion of these routines frees the application code from having to implement USB-specific code.

The tasks provided by the ROM code include:

- A USB engine for handling USB control endpoint data transactions and states
- USB protocol handlers to support USB Chapter 9
- USB protocol handlers to support USB HID Class
- USB protocol handlers to support USB DFU Class
- USB protocol handlers to support the common features of USB Audio Class commands
  - Feature Unit:
    - Set/get volume control
    - Set/get mute control
    - Set/get bass control
    - Set/get treble control
  - Mixer unit: set/get input/output gain control
  - End point: set/get the audio streaming endpoint sampling frequency
  - For unsupported case, the ROM code passes the requests to the application code for processing.

### 2.2.3 USB Enumeration

USB enumeration is accomplished by interaction between the host PC and the TAS1020A. As described in Section 2.2.2, the TAS1020A can identify itself as an application device by reporting its application Vendor ID and Product ID, or it can identify itself as a DFU device by reporting a Vendor ID of 0xFFFF and a Product ID of 0xFFFE. If the TAS1020A fails to detect the presence of an EEPROM, or if an EEPROM is present but does not contain a valid header, the Vendor ID of 0xFFFF and Product ID of 0xFFFE are reported. If an EEPROM is present, but contains only valid header data, the Vendor ID and Product ID settings in the EEPROM header are reported, but the TAS1020A firmware comes up as a DFU device in the DFU program mode. If an EEPROM is present, and contains both a valid header and application code, the TAS1020A comes up as an application specific device.

For all cases where the TAS1020A comes up in the DFU program mode, once application code has been downloaded, the TAS1020A is reset by a host-issued USB reset. After this reset, the TAS1020A comes up as an application device. When the TAS1020A comes up as an application device, the ROM-resident boot loader retrieves the application code from the EEPROM, if the EEPROM is not a device EEPROM, and then runs the application code. It is the application code that connects the TAS1020A to the USB. During the enumeration that follows connection to the USB, the application code identifies the device as an application specific device and the host loads the appropriate host driver(s).

The boot loader and application code both use the CONT, SDW and FRSTE bits to control the enumeration process.

- The function connect (CONT) bit is set to a 1 by the MCU to connect the TAS1020A device to the USB. When this bit is set to a 1, the USB DP line pullup resistor (PUR) output signal is enabled. Enabling PUR connects the pullup on the PCB to the TAS1020A 3.3-V digital supply voltage. (When the TAS1020A powers up, this bit is cleared to a 0 and the PUR output is in the high-impedance state.) This bit is not affected by subsequent USB resets.
- The shadow the boot ROM (SDW) bit is set to 1 by the MCU to switch the MCU memory configuration from boot loader mode to normal operating mode. Once set to 1, this bit is not affected by subsequent USB resets.
- The function reset enable (FRSTE) bit is set to a 1 by the MCU to enable the USB reset to reset all internal logic including the MCU. However, the shadow the ROM (SDW) and the USB function connect (CONT) bits are not reset. In addition, when the FRSTE bit is set, the reset output ( $\overline{RSTO}$ ) signal from the TAS1020A device is active whenever a USB reset occurs. This bit, once set, is not affected by subsequent USB resets.

## 2.2.4 TAS1020A USB Reset Logic

There are two mechanisms provided by the TAS1020A—an external reset  $\overline{\text{MRESET}}$  and a USB reset. The reset logic used in the TAS1020A is presented in Figure 2–2.

$\overline{\text{MRESET}}$  is a global reset that results in all the TAS1020A logic and the 8052 MCU core being reset. This input to the TAS1020A is typically used to implement a power-on reset at the application of power, but it can also be used with reset pushbutton switches and external circuits to implement global resets at any time.  $\overline{\text{MRESET}}$  is an asynchronous reset that must be active for a minimum time period of one microsecond.

The TAS1020A can also detect a USB reset condition. When this reset occurs, the TAS1020A responds by setting the function reset (RSTR) bit in the USB status register (USBSTA). However, the extent to which the internal logic is reset depends on the setting of the function reset enable bit (FRSTE) in the USB control register (USBCTL).

If the MCU has set FRSTE to 1, incoming USB resets are treated as global resets, with all TAS1020A logic and the 8052 MCU core being reset. However, the shadow the ROM (SDW) and the USB function connect (CONT) bits are not reset. Also, if the USB reset results in a global reset being issued, an interrupt to the 8052 MCU is not generated. But if the MCU has cleared FRSTE, incoming USB resets is treated as interrupts to the MCU (via  $\overline{\text{INT0}}$ ) if the corresponding function reset bit RSTR in the USB interrupt mask register USBMSK has been set by the MCU. If neither FRSTE or RSTR has been set by the MCU, USB resets have no effect on the TAS1020A, other than resetting the USB serial interface engine (SIE) and the USB buffer manager (UBM) in the TAS1020A.

Regardless of the status of FRSTE and bit RSTR in the USB interrupt mask register USBMSK, the function reset bit RSTR in the USB status register USBSTA is always set whenever a USB reset condition is detected. If the USB reset results in the generation of a global reset, the global reset clears the function reset bit RSTR in USBSTA. If, instead, the USB reset results in an interrupt being generated, RSTR in register USBSTA is cleared when the MCU writes to the interrupt vector register VECINT while in the USB reset interrupt service routine (VECINT = 0x17).

The TAS1020A has two reset outputs— $\overline{\text{RST0}}$  and  $\overline{\text{CRESET}}$ .  $\overline{\text{RST0}}$  is activated every time  $\overline{\text{MRESET}}$  is active, and every time a USB reset occurs and bit FRSTE in the USB control register USBCTL is set.  $\overline{\text{CRESET}}$  is typically used as a codec reset. Although labeled a reset line, it has no direct relationship to  $\overline{\text{MRESET}}$  or detected USB resets. Instead, it is activated and deactivated when the on-chip 8052 MCU core writes a 0 and a 1, respectively, to the CRST bit in the codec port interface control and status register CPTCTL.

## 2.2.5 USB Suspend and Resume Modes

The TAS1020A can recognize a suspend state. Figure 2–2 shows the logical implementation of the suspend and resume modes in the TAS1020A. The TAS1020A enters a suspend mode if a constant idle state (j state) is observed on the USB bus for a period of 5 ms. USB compliance also requires that a device enter a suspend state, drawing only suspend current from the bus, after no more than 10 ms of bus inactivity. The TAS1020A supports this requirement by creating a suspend interrupt to the on-chip MCU after a suspend condition has been present for 5 ms. Upon receiving this interrupt, the MCU firmware can then take the steps necessary to assure that the device enters a suspend state within the next 5 ms.

There are two ways for the TAS1020A device to exit the suspend mode: 1) detection of USB resume signaling and 2) proactively performing a local remote wake-up event.

### 2.2.5.1 USB Suspend Mode

When a suspend condition is detected on the USB, the suspend/resume logic sets the function suspend request bit (SUSR) in the USB status register, resulting in the generation of the function suspend request interrupt SUSR. To enter the low-power suspend state and disable all TAS1020A device clocks, the MCU firmware, upon receiving the SUSR interrupt, must set the idle mode bit (IDL), which is bit 0 in the MCU power control (PCON) register. Setting the IDL bit results in the TAS1020A suspending all internal clocks, including the clocks to the MCU. The MCU thus suspends instruction execution while in the idle mode.

The MCU must not set the IDL bit while in the SUSR interrupt service routine (ISR), or while in any other ISR. As described in Section 2.2.5.3, it is intended that the receipt of an  $\overline{\text{INT0}}$  interrupt at the MCU result in exiting the suspend state. But if the MCU has suspended instruction execution while in an ISR, subsequent  $\overline{\text{INT0}}$  activity is not recognized, as the MCU is still servicing an interrupt. For this reason then, it is necessary that IDL not be set while processing an ISR. (As described in Section 2.2.5.3, an external wake-up event will resume clocks within the TAS1020A. But even if the clocks to the MCU resume, if the MCU does not recognize  $\overline{\text{INT0}}$ , the IDL bit remains set and thus the MCU core itself remains in the suspend state).

The SUSR bit is cleared while in the SUSR ISR by writing to the interrupt vector register VECINT. While servicing the SUSR ISR, the VECINT output is 0x16 – the USB function suspend interrupt vector. As shown in Figure 2–2, the occurrence of a write to VECINT, while the USB function suspend interrupt vector is being output, results in clearing bit SUSR of the USB status register. (The data written to VECINT is of no consequence; the clearing action takes place upon decoding the write transaction to VECINT).

### 2.2.5.2 USB Resume Mode

When the TAS1020A is in a suspend state, any non-idle signaling on the USB is detected by the suspend/resume logic and device operation resumes. When the resume signal is detected, the TAS1020A clocks are enabled and the function resume request bit (RESR) is set, resulting in the generation of the function resume request interrupt. The function resume request interrupt to the MCU automatically clears the idle mode bit IDL in the PCON register, and as a result the MCU exits the suspend state and becomes fully functional, with all internal clocks active. After the RETI from the ISR, the next instruction to be executed is the one following the instruction that set the IDL bit. The RESR bit is cleared while in the RESR ISR by writing to the interrupt vector register VECINT.

### 2.2.5.3 USB Remote Wake-Up Mode

The TAS1020A device has the capability to remotely wake up the USB by generating resume signaling upstream, providing the host has granted permission to generate remote wake-ups via a SET\_FEATURE DEVICE\_REMOTE\_WAKEUP control transaction. If remote wakeup capability has been granted, the MCU firmware, upon awakening from a suspend state, has to activate the remote wake-up request bit RWUP in the USB control register USBCTL. Activation of RWUP consists of the MCU firmware writing a 1 followed by a 0 to RWUP. This action creates a pulse, which results in the TAS1020A generating resume signaling upstream by driving a k state (non-idle) onto the USB bus. The USB specification requires that remote wake-up resume signaling not be generated until the



suspend state has been active for at least 5 ms. In addition, the specification requires that the remote wake-up resume signaling be generated for at least 1ms but for no more than 15 ms. The 5 ms requirement is met by not entering the suspend mode until an idle state, or j state, is detected, uninterrupted, for 5 ms. The RWUP pulse results in driving a k state onto the USB bus for 1 to 2 ms, and thus the 15 ms requirement is also met. Moreover, if an application wishes to extend the duration of the k state on the USB bus, it need only extend the pulse width of RWUP. The resulting duration of the resume signaling is the duration of the RWUP pulse plus 1 to 2 ms.

The condition that activates a remote wake-up is a transition from 1 to 0 on one of the P3 port bits whose corresponding mask bit has been set to zero. (When in the suspend mode, the  $\overline{XINT}$  input is treated as port bit P3.2). As seen in Figure 2–2, the P3 mask register bits are gated with the P3 port input lines from the I/O port cells. The gated P3 port bits are then all ORed together and the output is ANDed with the suspend signal. The output of this logic drives the clock input of a flip-flop, and when the output of this logic transitions from 0 to 1, the flip-flop is set to 1. The setting of this flip-flop to 1 results in the TAS1020A exiting the suspend state and resuming all clocks, including those to the MCU core. The output of this flip-flop is also gated with bit XINTEN in the global control register GLOBCTL, and the output of this gate drives the  $\overline{INT0}$  interrupt logic. This means that a remote wake-up generates an  $\overline{INT0}$  interrupt to the MCU only if bit XINTEN has been set. Therefore, before entering a suspend state, the firmware must set XINTEN if remote wake-up capability is to be enabled.

The wake-up interrupt is seen by the firmware as an  $\overline{XINT}$  interrupt; that is, the interrupt vector register VECINT has an output value of 0x1F. If the  $\overline{XINT}$  pin is to be used as an event marker during normal operation, and if one of the P3 port bits is to be used for a wake-up interrupt, the firmware must be able to distinguish between a wake-up interrupt and a normal  $\overline{XINT}$  interrupt. One technique would be to examine the state of the IDL bit in the MCU power control register. If this bit is set, the interrupt event is a wake-up interrupt; otherwise, the interrupt is a normal  $\overline{XINT}$  interrupt. If an  $\overline{XINT}$  event should occur during a suspend mode, the event is ignored if the mask bit for P3.2 is set. (During a suspend mode the TAS1020A clocks are disabled, and thus an incoming  $\overline{XINT}$  interrupt event does not propagate through the synchronization logic and activate the MCU  $\overline{INT0}$  input).

## 2.2.6 Adaptive Clock Generator (ACG)

The adaptive clock generator is used to generate two programmable master clock output signals (MCLKO and MCLKO2) that can be used by the codec port interface and the codec device. Two separate and programmable frequency synthesizers provide the two master clocks. This allows the TAS1020A to support different record and playback rates for those devices that require separate master clocks to implement different rates. For isochronous transactions, the ACG can also support USB asynchronous, synchronous, and adaptive modes of operation. The ACG keeps count of the number of master clock events between USB SOF time marks, and the DCNTX/Y field of the endpoint register IEPDCNTX/Y keeps track of the number of samples received between USB SOF time marks. Synchronous isochronous operation can be accomplished by adjusting one of the two frequency synthesizers until the correct number of master clock events is obtained between USB SOF time marks. Similarly, monitoring the number of samples received between USB SOF events can accommodate adaptive isochronous operation. Here the frequency synthesizer is adjusted to obtain the proper codec output rate for the number of samples received. The TAS1020A can also accommodate asynchronous isochronous operation, and the input MCLKI is provided for this case. For asynchronous isochronous operation, the external clock pin MCLKI is used to derive the data and sync signal to the codec. However, the external clock that provides the input to pin MCLKI, instead of the master clock output (MCLKO or MCLKO2) from the ACG, must also source the codec's MCLK.

A block diagram of the adaptive clock generator is shown in Figure 2–1. Each frequency synthesizer circuit generates a programmable clock with a frequency range of 12–25 MHz, and each frequency synthesizer output feeds a divide-by-M-circuit, which can be programmed to divide by 1 to 16. As a result, the frequency range of each master clock is 750 kHz to 25 MHz. Also, the duty cycle of each master clock is 50% for all programmable frequencies.

As indicated in Figure 2–1, multiplexers precede the master clocks MCLKO and MCLKO2. These multiplexers provide the option of using the output of either frequency synthesizer (after division by the divide-by-M circuit) or the MCLKI input (after division by the divide-by-I circuit) to source each master clock. Each master clock is also assigned its own divide circuit to generate its associated CSCLK. The C-port serial clock (CSCLK) is derived by setting the *divide by B* value in codec port interface configuration register CPTNCF4 [2:0] and the C-port serial clock2 (CSCLK2) is derived by setting the *divide by B2* value in codec port receive interface configuration register 4 CPTRXCNF4 [2:0].

In addition, although not shown in Figure 2–1, each master clock is assigned its own CSYNC generator, with the length and polarity of each CSYNC separately programmable.

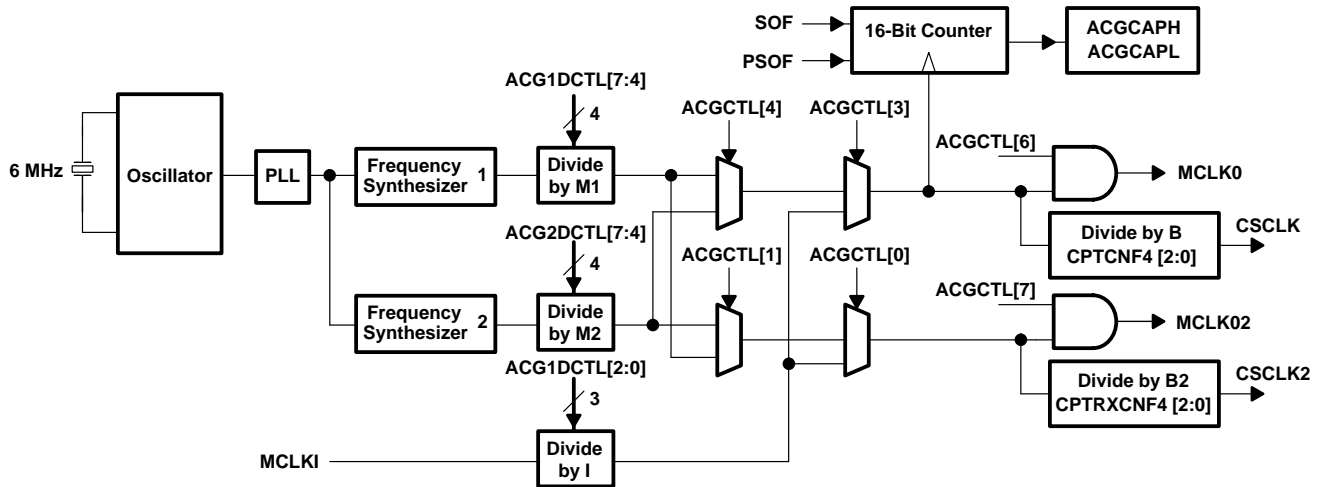

Figure 2–1. Adaptive Clock Generator

The ACG is controlled by the following registers. Refer to section A.5.3 for details.

FUNCTIONAL REGISTER	ACTUAL BYTE-WIDE REGISTERS		
24-bit frequency register #1	ACG1FRQ2	ACG1FRQ1	ACG1FRQ0
16-bit capture register		ACGCAPH	ACGCAPL
8-bit synthesizer 1 divider control register			ACG1DCTL
8-bit ACG control register			ACGCTL
24-bit frequency register #2	ACG2FRQ2	ACG2FRQ1	ACG2FRQ0
8-bit synthesizer 2 divider control register			ACG2DCTL

The main functional modules of the ACG are described in the following sections.

### 2.2.6.1 Programmable Frequency Synthesizer

The 24-bit ACG frequency register value is used to program the frequency synthesizer, and the value of the frequency register can be updated by the MCU while the ACG is running. The high resolution of each frequency value programmed allows the firmware to adjust the frequency value by +LSB or more to lock onto the USB start-of-frame (SOF) signal and achieve a synchronous mode of operation, a necessity for streaming audio applications. The 24-bit frequency register value is updated and used by the frequency synthesizer only when MCU writes to the ACGFRQ0 register. The proper way to update a frequency value then is to write the least significant byte (ACGFRQ0) last.

The frequency resolution of the output master clock depends on the actual frequency being output. In general, the frequency resolution decreases with increasing output frequencies. The clock frequency of the MCLK0 output signal is calculated by using the formula:

$$\text{For } N \geq 24 \text{ and } N < 50, \text{ MCLK0 frequency} = 600/N \text{ MHz}$$

$$\text{For } N = 50, \text{ MCLK0 frequency} = 12 \text{ MHz}$$

where N is the value in the 24-bit frequency register (ACGFRQ). The value of N can range from 24 to 50. The six most significant bits of the 24-bit frequency register are used to represent the integer portion of N, and the remaining 18 bits of the frequency register are used to represent the fractional portion of N. An example is shown below.

#### Example Frequency Register Calculation

Suppose the desired MCLK0 frequency is 24.576 MHz. Using the above formula,  $N = 24.4140625$  decimal. To determine the binary value to be written to the ACGFRQ register, separately convert the integer value (24) to 6-bit binary and the fractional value (4140625) to 18-bit binary. As a result, the 24-bit binary value is 011000.011010100000000000.

The corresponding values to program into the ACGFRQ registers are:

ACGFRQ2 = 01100001b = 61h

ACGFRQ1 = 10101000b = A8h

ACGFRQ0 = 00000000b = 00h

Keep in mind that writing to register ACGFRQ0 loads the frequency synthesizer with the new 24-bit value in registers ACGFRQ2, ACGFRQ1, and ACGFRQ0.

### Example Frequency Resolution Calculation

To illustrate the frequency resolution capabilities of the ACG, the next possible higher and lower frequencies for MCLKO can be calculated.

To get the next possible higher frequency of MCLKO (24.57600384 MHz), decrease the value of N by 1 LSB. Thus, N = 011000.01 – 10100111 – 11111111 binary.

To get the next possible lower frequency of MCLKO (24.57599600 MHz), increase the value of N by 1 LSB. Thus, N = 011000.01 – 10101000 – 00000001 binary.

For this example with a nominal MCLKO frequency of 24.576 MHz, the frequency resolution is approximately 4 Hz.

Table 2-2 lists typically used frequencies and the corresponding ACG frequency register values.

**Table 2–2. ACG Frequency Registers**

SYNTHESIZED CLOCK OUTPUT	ACG1FRQ2/ACG2FRQ2	ACG1FRQ1/ACG2FRQ1	ACG1FRQ0/ACG2FRQ0
25 MHz	0x60	0	0
24.576 MHz	0x61	0xA8	0x0F
22.579 MHz	0x6A	0x4B	0x20
18.432 MHz	0x82	0x35	0x55
16.934 MHz	0x8D	0xBA	0x09
16.384 MHz	0x92	0x7C	0x00
12.288 MHz	0xC3	0x50	0x00
12 MHz	0xC8	0	0

### 2.2.6.2 Capture Counter and Register

The capture counter and register circuit consists of a 16-bit free running counter which runs at the capture clock frequency. The capture clock source can be selected by programming bits MCLK01S0 and MCLK01S1 in the ACGCTL register. The options are the divided output of frequency synthesizer no. 1, the divided output of frequency synthesizer no. 2, or the divided input clock MCLKI. At each USB start-of-frame (SOF) event or pseudo-start-of-frame (PSOF) event, the capture counter value is stored into the 16-bit capture register. This value is valid until the next SOF or PSOF signal occurs (~1 ms). The MCU can read the 16-bit capture register value by reading the ACGCAPH and ACGCAPL registers. Because the counter is a free running counter, and because the count range of the counter extends over several frames before rolling over and beginning the count anew, the capture count values obtained are correlated over several SOF cycles. This attribute is useful should a case ever arise when the MCU fails to read the capture counter after a SOF event, and thus skips an SOF cycle.

As shown in Figure 2–1, there is only one capture counter and register, and its capture clock frequency is always the clock selection for MCLKO. This means that MCLKO2 cannot be synchronized to the incoming USB data stream. However, MCLKO2 is intended to support record capability for those cases where record and playback are conducted at different master clock frequencies. Synchronization to the USB bus for record is handled by the handshaking protocol established between the assigned DMA channel and the USB buffer manager (UBM) (see Section 2.2.7.4.1, Subsection *Circular Buffer Operation for Isochronous IN Transactions* for more detail). Thus it is not necessary that MCLKO2 itself be synchronized to the USB bus.

## 2.2.7 USB Transfers

The TAS1020A device supports all USB data transfer types: control, bulk, interrupt, and isochronous. In accordance with the USB specification, endpoint zero is reserved for the control endpoint and is bidirectional. In addition to the control endpoint, the TAS1020A is capable of supporting up to 7 IN endpoints and 7 OUT endpoints. These additional endpoints can be configured as bulk, interrupt, or isochronous endpoints.

### 2.2.7.1 Control Transfers

Control transfers are used for configuration, command, and status communication between the host PC and the TAS1020A device. Control transfers to the TAS1020A device use IN endpoint 0 and OUT endpoint 0. The three types of control transfers are control write, control write with no data stage, and control reads.

#### 2.2.7.1.1 Control Write Transfer (Out Transfer)

The host PC uses a control write transfer to write data to the USB function. A control write transfer always consists of a setup stage transaction and an IN status stage, and can optionally contain one or more data stage transactions between the setup and status transactions. If the data to be transferred can be contained in the two byte value field of the setup transaction data packet, no data stage transaction is required. If the control information requires the transfer of more than two bytes of data, a control write transfer with data stage transactions will be required. The steps followed for a control write transfer are:

##### Initialization Stage:

1. MCU initializes IN endpoint 0 and OUT endpoint 0 by programming the appropriate USB endpoint configuration blocks. This entails programming the buffer size and buffer base address, selecting the buffer mode, enabling the endpoint interrupt, initializing the TOGGLE bit, enabling the endpoint, and clearing the NACK bit for both IN endpoint 0 and OUT endpoint 0.

##### Setup Stage Transaction:

1. The host PC sends a setup token followed by the setup data packet addressed to OUT endpoint 0. If the data is received without an error, the USB Buffer Manager (UBM) writes the data to the setup data packet buffer, sets the setup stage transaction (SETUP) bit to a 1 in the USB status register, returns an ACK handshake to the host PC, and asserts the setup stage transaction interrupt. Note that as long as the setup stage transaction (SETUP) bit is set to a 1, the UBM returns a NACK handshake for any data stage or status stage transactions regardless of the endpoint 0 NACK or STALL bit values.
2. The MCU services the interrupt, reads the setup data packet from the buffer, and decodes the command. If the command is not supported or valid, the MCU should set the STALL bit in the OUT endpoint 0 configuration byte and the IN endpoint 0 configuration byte before clearing the setup stage transaction (SETUP) bit. This causes the device to return a STALL handshake for any data stage or status stage transactions. If the command decoded is supported, the MCU clears the interrupt, which automatically clears the setup stage transaction bit. The MCU also sets the TOGGLE bit in the OUT endpoint 0 configuration byte to a 1. For control write transfers, the PID used by the host for the first OUT data packet is a DATA1 PID and the TOGGLE bit must match.

##### Optional Data Stage Transaction:

1. The host PC sends an out token packet followed by a data packet addressed to OUT endpoint 0. If the data packet is received without errors the UBM writes the data to the endpoint buffer, updates the data count value, toggles the TOGGLE bit, sets the NACK bit to a 1, returns an ACK handshake to the host PC, and asserts the endpoint interrupt.
2. The MCU services the interrupt and reads the data packet from the buffer. To read the data packet, the MCU first must obtain the data count value. After reading the data packet, the MCU must clear the interrupt and clear the NACK bit to allow the reception of the next data packet from the host PC.

3. If the NACK bit is set to 1 when the in token packet is received, the UBM simply returns a NAK handshake to the host PC. If the STALL bit is set to 1 when the in token packet is received, the UBM simply returns a STALL handshake to the host PC. If a CRC or bit stuff error occurs when the data packet is received, then no handshake is returned to the host PC.

#### **Status Stage Transaction:**

1. For IN endpoint 0, the MCU clears the data count value to zero, sets the TOGGLE bit to 1, and clears the NACK bit to 0 to enable the data packet to be sent to the host PC. Note that for a status stage transaction a null data packet with a DATA1 PID is sent to the host PC.
2. The host PC sends an IN token packet addressed to IN endpoint 0. After receiving the IN token, the UBM transmits the null data packet to the host PC. If the data packet is received without errors by the host PC, an ACK handshake is returned. Upon receiving the ACK handshake, the UBM toggles the TOGGLE bit, sets the NACK bit to 1, and asserts the endpoint interrupt.
3. If the NACK bit is set to 1 when the IN token packet is received, the UBM simply returns a NAK handshake to the host PC. If the STALL bit is set to 1 when the IN token packet is received, the UBM simply returns a STALL handshake to the host PC. If no handshake packet is received from the host PC then the UBM prepares to retransmit the same data packet again.

#### **2.2.7.1.2 Control Read Transfer (In Transfer)**

The host PC uses a control read transfer to read data from the USB function. A control read transfer consists of a setup stage transaction, at least one in data stage transaction, and an out status stage transaction.

The steps followed for a control read transfer are:

#### **Initialization Stage:**

1. MCU initializes IN endpoint 0 and OUT endpoint 0 by programming the appropriate USB endpoint configuration blocks. This entails programming the buffer size and buffer base address, selecting the buffer mode, enabling the endpoint interrupt, initializing the TOGGLE bit, enabling the endpoint, and clearing the NACK bit for both IN endpoint 0 and OUT endpoint 0.

#### **Setup Stage Transaction:**

1. The host PC sends a setup token followed by the setup data packet addressed to OUT endpoint 0. If the data is received without an error, the UBM writes the data to the setup data packet buffer, sets the setup stage transaction (SETUP) bit to a 1 in the USB status register, returns an ACK handshake to the host PC, and asserts the setup stage transaction interrupt. Note that as long as the setup stage transaction (SETUP) bit is set to a 1, the UBM returns a NACK handshake for any data stage or status stage transactions regardless of the endpoint 0 NACK or STALL bit values.
2. The MCU services the interrupt, reads the setup data packet from the buffer, and decodes the command. If the command is not supported or is not valid, the MCU sets the STALL bit in the OUT endpoint 0 configuration byte and the IN endpoint 0 configuration byte before clearing the setup stage transaction (SETUP) bit. This causes the device to return a STALL handshake for any data stage or status stage transactions. If the command decoded is valid and is supported, the MCU clears the interrupt, which automatically clears the setup stage transaction bit. The MCU also sets the TOGGLE bit in the IN endpoint 0 configuration byte to a 1. For control read transfers, the PID used by the host for the first IN data packet is a DATA1 PID.

### **Data Stage Transaction:**

1. The data packet to be sent to the host PC is written to the IN endpoint 0 buffer by the MCU. The MCU also updates the data count value then clears the IN endpoint 0 NACK bit to a 0 to enable the data packet to be sent to the host PC.
2. The host PC sends an IN token packet addressed to IN endpoint 0. After receiving the IN token, the UBM transmits the data packet to the host PC. If the data packet is received without an error by the host PC, then an ACK handshake is returned. The UBM then toggles the TOGGLE bit, sets the NACK bit to 1, and asserts the endpoint interrupt.
3. The MCU services the interrupt and prepares to send the next data packet to the host PC.
4. If the NACK bit is set to 1 when the IN token packet is received, the UBM simply returns a NAK handshake to the host PC. If the STALL bit is set to 1 when the IN token packet is received, the UBM simply returns a STALL handshake to the host PC. If no handshake packet is received from the host PC, then the UBM prepares to retransmit the same data packet again.
5. MCU continues to send data packets until all data has been sent to the host PC.

### **Status Stage Transaction:**

1. For OUT endpoint 0, the MCU sets the TOGGLE bit to 1, then clears the NACK bit to a 0 to enable a data packet to be sent by the host PC. Note that for a status stage transaction a null data packet with the DATA1 PID is sent by the host PC.
2. The host PC sends an OUT token packet and the null data packet to OUT endpoint 0. If the data packet is received without an error the UBM updates the data count value, toggles to the TOGGLE bit, sets the NACK bit to a 1, returns an ACK handshake to the host PC, and asserts the endpoint interrupt.
3. The MCU services the interrupt. If the status transaction completed successfully, then the MCU clears the interrupt and clears the NACK bit.
4. If the NACK bit is set to 1 when the OUT token packet is received, the UBM simply returns a NAK handshake to the host PC. If the STALL bit is set to 1 when the OUT token packet is received, the UBM simply returns a STALL handshake to the host PC. If a CRC or bit stuff error occurs when the data packet is received, no handshake is returned to the host PC.

#### **2.2.7.2 Interrupt Transfers**

The TAS1020A supports interrupt data transfers both to and from the host PC. Devices that need to send or receive a small amount of data with a specified service period should use the interrupt transfer type. IN endpoints 1 through 7 and OUT endpoints 1 through 7 can all be configured as interrupt endpoints.

##### **2.2.7.2.1 Interrupt Out Transaction**

The steps followed for an interrupt out transaction are:

1. MCU initializes one of the OUT endpoints as an out interrupt endpoint by programming the appropriate USB endpoint configuration block. This entails programming the buffer size and buffer base address, selecting the buffer mode, enabling the endpoint interrupt, initializing the toggle bit, enabling the endpoint, and clearing the NACK bit.
2. The host PC sends an OUT token packet followed by a data packet addressed to the OUT endpoint. If the data is received without an error then the UBM writes the data to the endpoint buffer, updates the data count value, toggles the toggle bit, sets the NACK bit to a 1, returns an ACK handshake to the host PC, and asserts the endpoint interrupt.
3. The MCU services the interrupt and reads the data packet from the buffer. To read the data packet, the MCU must first obtain the data count value. After reading the data packet, the MCU clears the interrupt and clears the NACK bit to allow the reception of the next data packet from the host PC.

4. If the NACK bit is set to a 1 when the data packet is received, the UBM simply returns a NACK handshake to the host PC. If the STALL bit is set to 1 when the data packet is received, the UBM simply returns a STALL handshake to the host PC. If a CRC or bit stuff error occurs when the data packet is received, no handshake is returned to the host PC.

**NOTE:** In double buffer mode for interrupt out transactions, the UBM selects between the X and Y buffer based on the value of the toggle bit. If the toggle bit is a 0, the UBM writes the data packet to the X buffer. If the toggle bit is a 1, the UBM writes the data packet to the Y buffer. When a data packet is received, the MCU determines which buffer contains the data packet by reading the toggle bit. However, when using double buffer mode, the possibility exists for data packets to be received and written to both the X and Y buffer before the MCU responds to the endpoint interrupt. In this case, simply use the toggle bit to determine which buffer contains the data packet does not work. Hence, in double buffer mode, the MCU reads the X buffer NACK bit, the Y buffer NACK bit, and the toggle bit to determine the status of the buffers.

#### 2.2.7.2.2 *Interrupt In Transaction*

The steps followed for an interrupt in transaction are:

1. MCU initializes one of the IN endpoints as an in interrupt endpoint by programming the appropriate USB endpoint configuration block. This entails programming the buffer size and buffer base address, selecting the buffer mode, enabling the endpoint interrupt, initializing the toggle bit, enabling the endpoint, and setting the NACK bit.
2. The data packet to be sent to the host PC is written to the buffer by the MCU. The MCU also updates the data count value and clears the NACK bit to 0 to enable the data packet to be sent to the host PC.
3. The host PC sends an IN token packet addressed to the IN endpoint. After receiving the IN token, the UBM transmits the data packet to the host PC. If the data packet is received without errors by the host PC, an ACK handshake is returned. The UBM then toggles the toggle bit, sets the NACK bit to a 1, and asserts the endpoint interrupt.
4. The MCU services the interrupt and prepares to send the next data packet to the host PC.
5. If the NACK bit is set to a 1 when the in token packet is received, the UBM simply returns a NACK handshake to the host PC. If the STALL bit is set to a 1 when the IN token packet is received, the UBM simply returns a STALL handshake to the host PC. If no handshake packet is received from the host PC, then the UBM prepares to retransmit the same data packet.

**NOTE:** In double buffer mode for interrupt IN transactions, the UBM selects between the X and Y buffer based on the value of the toggle bit. If the toggle bit is a 0, the UBM reads the data packet from the X buffer. If the toggle bit is 1, the UBM reads the data packet from the Y buffer.

#### 2.2.7.3 Bulk Transfers

The TAS1020A supports bulk data transfers both to and from the host PC. Devices that need to send or receive a large amount of non time-critical data should use the bulk transfer type. IN endpoints 1 through 7 and OUT endpoints 1 through 7 can be configured as bulk endpoints. TAS1020A supports single and double buffering for bulk transfers.

##### 2.2.7.3.1 *Bulk Out Transaction Using MCU*

The steps for a bulk out transaction are as follows:

1. MCU initializes one of the OUT endpoints as an OUT bulk endpoint by programming the appropriate USB endpoint configuration block. This entails programming the buffer size and buffer base address, selecting the buffer mode, enabling the endpoint interrupt, initializing the toggle bit, enabling the endpoint, and clearing the NACK bit.

2. The host PC sends an OUT token packet followed by a data packet addressed to the OUT endpoint. If the data is received without an error, the UBM writes the data to the endpoint buffer, updates the data count value, toggles the toggle bit, sets the NACK bit to a 1, returns an ACK handshake to the host PC, and asserts the endpoint interrupt.
3. The MCU services the interrupt and reads the data packet from the buffer. To read the data packet, the MCU must first retrieve the data count value. After reading the data packet, the MCU clears the interrupt and clears the NACK bit to allow the reception of the next data packet from the host PC.
4. If the NACK bit is set to 1 when the data packet is received, the UBM simply returns a NACK handshake to the host PC. If the STALL bit is set to 1 when the data packet is received, the UBM simply returns a STALL handshake to the host PC. If a CRC or bit stuff error occurs when the data packet is received, no handshake is returned to the host PC.

**NOTE:** In double buffer mode for bulk OUT transactions, the UBM selects between the X and Y buffer based on the value of the toggle bit. If the toggle bit is a 0, the UBM writes the data packet to the X buffer. If the toggle bit is a 1, the UBM writes the data packet to the Y buffer. When a data packet is received, the MCU determines which buffer contains the data packet by reading the toggle bit. However, when using double buffer mode, data packets may be received and written to both the X and Y buffer before the MCU responds to the endpoint interrupt. In this case, simply using the toggle bit to determine which buffer contains the data packet does not work. Hence, in double buffer mode, the MCU reads the X buffer NACK bit, the Y buffer NACK bit, and the toggle bit to determine the status of the buffers.

#### 2.2.7.3.2 Bulk In Transaction Using MCU

The steps followed for a bulk in transaction are:

1. MCU initializes one of the IN endpoints as an IN bulk endpoint by programming the appropriate USB endpoint configuration block. This entails programming the buffer size and buffer base address, selecting the buffer mode, enabling the endpoint interrupt, initializing the toggle bit, enabling the endpoint and setting the NACK bit.
2. The data packet to be sent to the host PC is written to the buffer by the MCU. The MCU also updates the data count value then clears the NACK bit to a 0 to enable the data packet to be sent to the host PC.
3. The host PC sends an IN token packet addressed to the IN endpoint. After receiving the IN token, the UBM transmits the data packet to the host PC. If the data packet is received without errors by the host PC, an ACK handshake is returned. The UBM then toggles the toggle bit, sets the NACK bit to a 1, and asserts the endpoint interrupt.
4. The MCU services the interrupt and prepares to send the next data packet to the host PC.
5. If the NACK bit is set to 1 when the in token packet is received, the UBM simply returns a NAK handshake to the host PC. If the STALL bit is set to 1 when the IN token packet is received, the UBM simply returns a STALL handshake to the host PC. If no handshake packet is received from the host PC, the UBM prepares to retransmit the same data packet again.

**NOTE:** In double buffer mode for bulk IN transactions, the UBM selects between the X and Y buffer based on the value of the toggle bit. If the toggle bit is a 0, the UBM reads the data packet from the X buffer. If the toggle bit is a 1, the UBM reads the data packet from the Y buffer.

#### 2.2.7.3.3 Bulk Out Transaction Through DMA

This transaction is used by mass storage class USB applications to move bulk data to an external device via the TAS1020A DMA resources. The difference between MCU-supported bulk transactions and DMA-supported bulk transactions lies in how the data in the assigned out endpoint buffer is distributed to its final destination. Two modes of DMA operation are possible. One mode is a software handshake mode utilizing synchronization communication between the MCU, the USB Buffer Manager (UBM), and an external device. The second mode is a direct exchange mode that bypasses communication with the MCU and directly outputs USB packets to an external device via the DMA resources. Higher bandwidth transactions can be achieved in the direct exchange mode.



In both modes, the on-chip C-port is used to output the received bulk data to an external device. To implement DMA-supported transactions, the C-port must be programmed to operate in either a general-purpose (GP) mode or an Audio Codec '97 (AC97) mode. When in the general-purpose mode, SYNC is disabled when there is no valid data in the buffer to be output; in the AC97 mode, the time slot *valid* bits in the tag field are disabled when there is no valid data in the buffer to be output.

### Software Handshake Using MCU, UBM, and External Device

Bulk data has the lowest priority of all transfers on the USB bus. But when there is little other activity on the USB bus, bulk transfers can achieve significant transfer rates. Bulk transfer rates then can fluctuate greatly, and for this reason it is sometimes necessary to monitor the transfer rate of bulk transfers in order to throttle back the transfer rate when the rate exceeds the bandwidth of the target device. The software handshake mode is provided to enable the implementation of just such a *throttling* of data.

The following steps explain the operation of the software handshake mode.

1. The MCU initializes one of the OUT endpoints as a bulk OUT endpoint by programming the appropriate USB endpoint configuration block. This entails programming the buffer size and buffer base address, selecting the buffer mode, enabling the endpoint interrupt, initializing the toggle bit, enabling the endpoint, and clearing the NACK bit.
2. To configure a given DMA channel to process a given endpoint in a software handshake mode, the MCU must
  - Enable the handshake mode by setting the HSKEN bit in the DMA channel control register (DMACTL0 and DMACTL1) to 1. In this same register the MCU must also program the USB endpoint direction and endpoint number fields.
  - Program the DMA current buffer content register (DMABPCT0 and DMABPCT1) with the number of bulk out packets to be handled by the DMA process without MCU intervention once the MCU has invoked the DMA process.
  - Program the DMA channel time slot assignment register (DMATSH0 and DMATSH1) with the time slot assignments to be supported by the DMA channel and the number of bytes to be transferred for each supported time slot.
3. The MCU must also appropriately configure the C-port. (See Section 2.2.7.4 for more detail on initializing the C-port). Note that if the C-port is placed in mode 0 (general-purpose mode) the CPTBLK bit in the codec port interface configuration register 4 must be set to 1 to assure that SYNC is disabled when there is no valid data in the buffer to be output.
4. Data is now ready to be received. The UBM, after receiving the bulk out packet and placing it in the appropriate buffer, toggles the toggle bit if the double-buffer mode is set, sets the NACK bit to 1, stores the packet data count in the data count register, and issues an interrupt to the MCU.
5. If the external device indicates that it is ready to receive data, the MCU enables the DMA process by setting the DMAEN bit the DMA channel control register (DMACTL0 and DMACTL1). (Handshaking between the MCU and external device will have to have taken place earlier to determine the status of the external device).
6. Once enabled, the DMA engine proceeds to transfer the contents of the buffer(s) to the C-port for transmittal to the external device. Data availability in the buffer(s) is determined by examining the NACK flags – which are set to 1 when data has been received. For the double buffer case, the buffer to be used to retrieve data for the C-port is determined by not only examining the NACK flags but also by monitoring the state of the toggle bit. The NACK bit is cleared by the DMA logic (as opposed to the MCU) each time an entire buffer content has been transferred to the C-port via DMA.
7. If the number of bulk out packets to be handled by the DMA process without MCU intervention is greater than one (the number can be as high as 64K packets), multiple buffer writes take place before the DMA process completes. Every time a data packet is written to a given buffer, the UBM generates the MCU

endpoint interrupt. If the MCU wishes to remain autonomous to the DMA process, the MCU must mask off the MCU endpoint interrupt (by clearing the OEPIE bit in the USB out configuration register OEPCNFx) before enabling the DMA process.

8. When the DMA process completes, the DMA channel disables itself and issues a DMA0 or a DMA1 interrupt to the MCU. Upon receiving the interrupt, the MCU knows that DMABPCT packets have been sent out to the C-port. The MCU then enables the appropriate endpoint interrupt (if it had been previously masked off). The process is now complete.

### **Direct Exchange Mode**

This mode offers the highest bandwidth for bulk OUT transactions. The process is almost identical to the software handshake mode, the only difference being that the Direct Exchange mode, once enabled, runs continuously until disabled; whereas the Software handshake mode only remains active for the processing of DMABPCT packets. The Direct Exchange mode is selected by clearing the bit HSKEN in the DMA channel control register (DMACTL0 and DMACTL1). When the MCU enables the DMA process, after appropriately setting up the endpoint configuration registers, the C-port configuration registers, and the DMA channel, the DMA process remains active until disabled by the MCU. While the DMA channel is active, received packets continue to be retrieved from the appropriate endpoint buffer and transferred to the C-port for transmission to the external device.

#### *2.2.7.3.4 Bulk IN Transaction Using DMA*

The TAS1020A does not support BULK IN using the DMA resources.

#### **2.2.7.4 Isochronous Transfers**

The TAS1020A supports isochronous data transfers both to and from the host PC. Devices that need to send or receive data at a constant rate must use the isochronous transfer type rate if the bandwidth of the data exceeds the USB bandwidth allotted to interrupt type transactions. IN endpoints 1 through 7 and OUT endpoints 1 through 7 can all be configured as isochronous endpoints.

Isochronous transfers must include the use of a DMA channel; MCU-supported isochronous transfers are not allowed. Since the TAS1020A has only two DMA channels, at any point in time only two isochronous transactions can be concurrently supported by the TAS1020A.

To setup an isochronous IN or an isochronous OUT transaction, the MCU must initialize the appropriate IN or OUT USB endpoint configuration block. For isochronous transactions, this entails programming the buffer size and buffer base address, enabling the endpoint interrupt, setting the ISO bit (to flag that the endpoint is an isochronous endpoint), clearing the NACK bit, and enabling the endpoint. When the ISO bit is set, the hardware configures the buffer to be a single circular buffer (see Section 2.2.7.4.1), using the endpoint buffer size register I/OEPBSIZx and buffer base address register I/O EPBBAXx. The size of the circular buffer is the size specified in I/OEPSIZx. (This is not to be confused with the same value in I/OEPSIZx yielding two buffers of that size when the double buffer mode is selected for control, interrupt, and bulk transactions.)

The TAS1020A DMA engine has two DMA channels. Each channel can be assigned to any IN or OUT endpoint that has been configured as an isochronous endpoint. (As previously discussed, DMA channels can also be assigned to bulk out endpoints). If an isochronous OUT endpoint receives data, the DMA channel assigned to the endpoint will retrieve the data from the endpoint buffer and transfer it to the C-port for outputting to the external device. If a DMA channel is assigned to an isochronous IN endpoint, the DMA channel transfers external device data received on the C-port to the IN endpoint buffer.

Each DMA channel can only implement data flow between endpoint buffers and the C-port. The configuration of each DMA channel includes a 14-bit field that defines which of the up to 14 time slots in the C-port audio frame the DMA channel supports. Both DMA channels could thus service OUT endpoints, or IN endpoints, with each DMA channel supporting different time slots in the audio frame.

Each DMA channel also provides a current buffer count register (DMABCNT0/1). For isochronous OUT transactions, the count in the register represents the number of bytes being transferred from the OUT endpoint buffer to the C-port

during the current USB frame. A new count is derived at each USB SOF event, and is the value of the write pointer address setting minus the read pointer address setting at the time of the USB SOF event. The MCU can read the content of this register.

The steps required to service DMA-supported isochronous transfers are:

1. The MCU initializes an IN or OUT USB endpoint configuration block. This entails programming the buffer size and buffer base address, setting the ISO bit, setting the number of bytes per isochronous channel, clearing the NACK bit, and enabling the endpoint. Because the endpoint is configured as an isochronous endpoint, the buffer configuration parameters are used to implement a circular buffer rather than one or two linear buffers, and the size specified is the size of the single circular buffer.
2. The MCU configures the selected DMA channel. This entails:
  - Programming registers DMATSH0/1 and DMATSL0/1, which consists of assigning the time slots to be used and the number of bytes to be transferred per time slot.
  - Programming register DMACTL0/1, which consists of setting the USB endpoint direction, selecting the endpoint number, and setting the DMA channel enable bit DMAEN.
3. The MCU configures the C-port. This entails:
  - Programming register CPTCNF1, which consists of setting the number of time slots per audio frame and selecting the C-port interface mode (general purpose mode, AIC mode, etc.).
  - Programming register CPTCNF2, which consists of setting the length of time slot 0 (number of CSCLK serial clock cycles), setting the length of the remaining time slots (which are all the same in length), and setting the number of data bits per time slot.
  - Programming register CPTCNF3, which consists of:
    - Setting the state of DDLY. A 1 programs a one CSCLK clock delay on the data output and data input signals with reference to the leading edge of CSYNC. A 0 removes the delay.
    - Setting the state of TRSEN. A 1 sets the C-port output to the high-impedance state for those time slots that have no valid data.
    - Setting the state of CSCLKP. A 1 programs the C-port to be CSCLK falling edge active (CDATO and CSYNC transition on falling edge of CSCLK and DATI is sampled on rising edge of CSCLK). A 0 results in activity on the opposite edges of CSCLK.
    - Setting the state of CSYNCP. A 1 programs CSYNC to be active high. A 0 programs CSYNC to be active low.
    - Setting the state of CSYNCL. A 1 programs the length of CSYNC to be the same number of CSCLK cycles as time slot 0. A 0 programs CSYNC to be one CSCLK cycle in length.
    - Setting the state of BYOR. A 1 results in the DMA reversing the byte order in moving data to/from the endpoint buffer.
    - Setting the state of CSCLKD. A 1 sets the CSCLK port as an input port (TAS1020A receives CSCLK). A 0 sets the CSCLK port as an output port (TAS1020A sources CSCLK).
    - Setting the state of CSYNCD. A 1 sets the CSYNC port as an input port (TAS1020A receives CSYNC). A 0 sets the CSYNC port as an output port (TAS1020A sources CSYNC).
  - Programming register CPTCNF4, which consists of:
    - Specifying the 4-bit field ATSL. This field defines which time slot is to be used for secondary communication (command/status) address and data.
    - Setting the state of CPTBLK. When DMA is to be used to transport USB bulk transfers to external devices via the C-port, the C-port must be placed in either a general-purpose mode or an AC97 mode, and CPTBLK must be set to one. When the C-port is placed in the general-purpose mode, a state of 1 for CPTBLK results in CSYNC only being present when valid data is present in the current

frame. When the C-port is placed in the AC97 mode, a state of 1 for CPTBLK results in CSYNC always being present, but the tag bits in time slot 0 being set to indicate the presence or absence of data. When CPTBLK is set to 0, CSYNC and CSCLK are free running once the C-port is enabled.

- Specifying the 3-Bit field DIVB. This defines the divide ratio of MCLK to CSCLK.
- Programming bits 4–7 of register CPTCTL to enable or disable the C-port transmit and receive interrupts. Bits 1–2 of register CPTCTL are used to select between primary and secondary codecs when using two codecs in the AC97 mode. Bit 0 of register CPTCTL (CRST), when cleared to 0, is used to issue resets to external devices via the  $\overline{\text{CRESET}}$  output pin.

**NOTE:** C-port registers CPTADR, CPTDATH and CPTDATH are accessed during run time operation to set the address, the data, and the mode (receive (status) or command (write)) for secondary communications. Registers CPTVSLH and CPTVSLH are only used when the AC97 mode is selected and are used to specify which time slots in the audio frame contain valid data. Registers CPTRXCNF2, CPTRXCNF3, and CPTRXCNF4 must be initialized when the C-port is used in the I<sup>2</sup>S mode (mode 5) to support an ADC and a DAC running at different frequencies.

#### 2.2.7.4.1 Circular Memory Buffer Implementation

A significant feature of DMA-supported isochronous transfers is the circular memory structure used to buffer the incoming data. In most applications, the C-port timing is derived from the USB frame rate using a soft-PLL provided in the TAS1020A firmware. However, the USB frame rate can vary within specified boundaries, and the output phase of the PLL can lag (or lead) the input during such variations. If a linear ping pong buffer implementation is used, tolerance must be built into switching between buffers to accommodate all possible magnitudes of variation in the relative timing between the input and output time references. A circular buffer topology greatly simplifies the implementation of the buffer as the need for decision points on when to switch buffers is eliminated.

The circular buffer implementation used in TAS1020A utilizes the same endpoint start (I/OEPBBAXx) and size (I/OEPBSIZx) assignment used by the linear buffer implementation, and the size of the circular buffer is the size specified in I/OEPBSIZx. The circular buffer implementation does require the use of two additional registers – a read pointer and a write pointer. These two registers are controlled by hardware, but are made available to the MCU for debug purposes.

#### Circular Buffer Operation for Isochronous OUT Transactions

The operation of the circular buffer for isochronous OUT transactions is as follows.

- Initially, the *read* and *write* pointers are set in hardware to the OUT endpoint start address.
- As the first packet of isochronous data addressed to the endpoint is received, the UBM stores the data into the circular buffer and updates the value of the *write* pointer by a count of one for each byte written into the buffer.
- As soon as the DMA channel detects that the read and write pointers are not the same value (data is available), the DMA channel could begin immediately retrieving data and outputting it to the C-port. However, the DMA channel waits until the next USB SOF is received.
- Once the DMA channel has waited until the next SOF is received, the buffer contains a full packet of data. Upon receiving SOF, the DMA channel further waits until the start of the next C-port frame and then begins transferring the buffered data to the C-port, updating the *read* pointer by one count for each byte of data transferred. At the C-port the data is output to the external device in accordance with the timing requirements of the external device (8 frames for 8 kHz audio sampling, 48 frames for 48 kHz audio sampling, etc.). The DMA channel continues to retrieve data from the buffer and output it to the C-port, update the *read* pointer, and check the value of the *write* pointer. Should the DMA-controlled *read* pointer value ever equal the value of the UBM-controlled write pointer, the process goes on hold and awaits the next USB SOF, where the process again resumes.

When the UBM completes writing a packet of data into the endpoint buffer, it loads the data count value of that packer (number of data samples, not bytes) into field DCNTX/Y of register OEPDCNTX/Yx. The register chosen, OEPDCNTX or OEPDCNTY, is determined by the LSB of the frame count register USBFNL. An

LSB value of 1 chooses OEPDCNTY; a value of 0 chooses OEPDCNTX. This count value does not play a role in implementing the data flow for isochronous out transactions, but is provided for and can be accessed by the MCU. As is discussed in the next section, the counts do play a role in implementing the data flow for isochronous in transactions.

- The streaming of audio data via the DMA channel continues indefinitely until the DMA engine is halted by the MCU.

### Circular Buffer Operation for Isochronous IN Transactions

For isochronous out transactions, the handshake implemented between the USB bus and the output device ensures that at each USB SOF event, the output has access to a complete USB frame of data. For isochronous in transactions, the mirror condition must be true: the handshake implemented between the USB bus and the input device must ensure that at each USB SOF event, the UBM has access to one or more complete frames of device data. Isochronous out transactions also ensure, by definition, that a complete USB frame of data is transmitted between USB SOF events. But the mirror condition here is not true, there may not be an integer number of device frames received between USB SOF events.

If, at each USB SOF event, the UBM is to have access to one or more complete frames of data from the input device, the latest codec frame available to the UBM has to have completed prior to the USB SOF event. But it is not known when the last input device frame to complete prior to the USB SOF event occurs. Thus a timing mark must be set up to mark the worst case arrival time of the last complete input device frame prior to the USB SOF event. The slowest sampling rate supported for an input device is set at 8 kHz (8 kHz audio sampling). At 8 kHz, a frame arrives from the input device every 0.125 milliseconds, which is 1500 12 MHz USB clock periods. Thus a *time mark* can be set to occur 1500 clock periods before the next USB SOF event. When this *time mark* occurs, the DMA completes the current input device frame, if a frame is currently being received, and then sets a handshake flag. The DMA also updates the content of register IEPDCNTX/Y with the total number of samples collected since the previous handshake flag was set. When the USB SOF event occurs, the UBM looks at the flag to see if data is available. If data is available, the UBM refers to the count in the register to determine how much data is to be output on the next isochronous in transaction.

To accommodate variations in the number of clocks at the output of the soft PLL, with respect to the incoming 12 MHz USB data rate, the *time mark* count is actually set to 1511, rather than 1500. The extra 11 clock periods assures that the last frame prior to the USB SOF event will have completed. The flag used is the NACK bit in the IEPDCNTX/Y register, and the data count is the 7-bit DCNTX/Y field in the same register. For isochronous in transactions, the register chosen, IEPDCNTX or IEPDCNTY, is also determined by the LSB of the frame count register USBFNL. But in the case of isochronous in transactions, an LSB value of 1 chooses IEPDCNTX and a value of 0 chooses IEPDCNTY. The selection logic for isochronous in transactions then is the reverse of that used for isochronous out transactions.

The operation of the circular buffer for isochronous in transactions is as follows.

- Initially, the *read* and *write* pointers are set in hardware to the IN endpoint start address. At the same time the NACK flags in the IEPDCNTX and IEPDCNTY registers are set to logic 1 and the DCNTX and DCNTY counts are cleared.
- As the input device frames are received, they are stored in the circular buffer by the DMA engine. As each byte is stored in the buffer, the DMA engine updates the write pointer by one count, and also keeps count of the number of samples being stored.
- When the *time mark* occurs, marking that there are 1511 USB clock periods remaining until the next USB SOF event occurs, the DMA engine awaits the completion of the current incoming input device frame (if one is currently being received). When the incoming input device frame completes, the DMA engine sets the NACK flag in IEPDCNTX/Y to logic 0 and loads the number of samples received into the DCNTX/Y field of IEPDCNTX/Y.
- At this time, the DMA engine zeroes its running count of data samples and awaits the next input device frame. For the DMA engine, the process repeats, and at the next *time mark*, the DMA engine sets the NACK flag in IEPDCNTX/Y to logic 0 and loads the number of samples received into the DCNTX/Y field of IEPDCNTX/Y.

- At the same time that the DMA engine reinitializes itself to receive the next input device frame, the UBM has noted the clearing of the NACK flag in IEPDCNTX/Y. When this occurs, the UBM knows that one or more complete frames reside in the circular buffer, starting at the address pointed to by the *read* buffer, and that the integer number of frames comprise a total of DCNTX/Y samples. When the USB SOF event occurs, the UBM is thus prepared and can respond to the USB isochronous in transaction when it occurs. As the UBM retrieves data during the isochronous in transaction, it updates the *read* pointer by one count for each byte retrieved. When DCNTX/Y samples have been output, the NACK bit in IEPDCNTX/Y is set back to logic 1 and the isochronous transaction is terminated. The UBM now awaits the clearing of the NACK bit in IEPDCNTX/Y and the occurrence of the next USB SOF event, at which time the process repeats. The UBM now continues to alternate (ping pong) between the data count and NACK flag value in register IEPDCNTX and the data count and NACK flag value in register IEPDCNTY until the DMA process is terminated by the MCU.
- If an isochronous in token is received when there is no new data to be output (the NACK flag bits in both IEPDCNTX and IEPDCNTY registers are at logic 1), the UBM will respond to the isochronous in request with a NULL packet.

### 2.2.8 Microcontroller Unit

The TAS1020A chip contains an 8-bit microcontroller core for control and supervisory functions. The microcontroller core used is based on the industry standard 8052. It is software compatible (including instruction execution times) with the industry standard 8052AH and 8052BH discrete devices, having all their core features plus the additional features corresponding to standard 8052 / 8032 / 80C52BH / 80C32BH / 87C52 parts – except the ONCE mode and program lock are not supported.

The MCU core has three 16-bit timer/counter units and a full-duplex serial port (UART). The timer/counter units and the UART are made available via the port 3 bits; thus some of the port 3 bits have dual functionality assignments in accordance with the 80C51 family of microcontrollers (see Section 2.2.11 for more detail on the dual functionality of port 3).

### 2.2.9 External MCU Mode Operation

An external MCU mode of operation is provided for firmware development using an in-circuit emulator (ICE). The external MCU mode is selected by setting pin EXTEN on the TAS1020A high. When the external MCU mode is selected, the internal 8052 MCU core of the TAS1020A is disabled. Also in the external MCU mode, the GPIO ports are used for the external MCU data, address, and control signals. Refer to section 1.7, *Terminal Functions – External MCU Mode*, for details. When in the external mode of operation, the external MCU or ICE is able to access the memory mapped IO registers, the USB configuration blocks and the USB buffer space in the TAS1020A.

Texas Instruments has developed a TAS1020A evaluation module (EVM) to allow customers to develop application firmware and to evaluate device performance. The EVM board provides a 40-pin dip socket for an ICE and headers to allow expansion of the system in a variety of ways.

### 2.2.10 Interrupt Logic

The 8052 MCU core used in the TAS1020A supports the five standard 8052 MCU interrupt sources. These five standard MCU interrupt sources are timer 0, timer 1, serial port, external 1 ( $\overline{INT1}$ ), and external 0 ( $\overline{INT0}$ ). The timer 0, timer 1, and serial port interrupts are MCU-internal interrupts, but  $\overline{INT0}$  and  $\overline{INT1}$  are external to the MCU core. Figure 2–2 shows the associated interrupt circuitry external to the MCU core, but within the TAS1020A chip.  $\overline{INT0}$  is input into the MCU core via port 3 bit P3.2, and  $\overline{INT1}$  is input into the MCU core via port 3 bit P3.3. P3.3 can also be configured, under firmware control, to serve as a general-purpose IO (GPIO) port bit. But the input side of P3.2 must be dedicated to servicing the  $\overline{INT0}$  function, as all additional interrupt sources from within the TAS1020A device are ORed together to generate the  $\overline{INT0}$  signal into port 3, bit P3.2. The other interrupt sources are: the eight USB IN endpoints, the eight USB OUT endpoints, USB function reset, USB function suspend, USB function resume, USB start-of-frame, USB pseudo start-of-frame, USB setup stage transaction, USB setup stage transaction over-write, codec port interface transmit data register empty, codec port interface receive data register full, I<sup>2</sup>C interface transmit data register empty, I<sup>2</sup>C interface receive data register full, DMA channel 0, DMA channel 1, and the external interrupt  $\overline{XINT}$ .

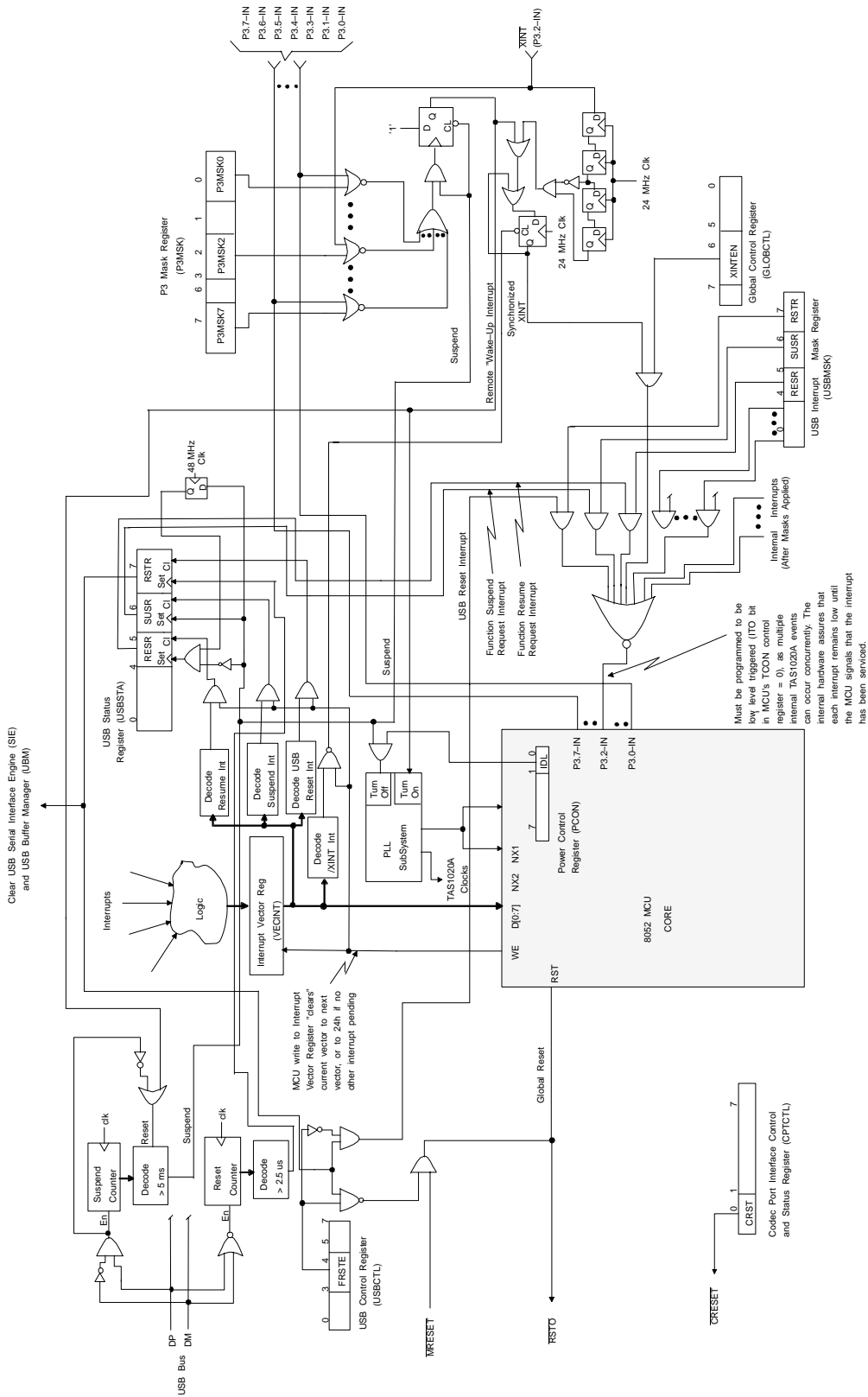

- NOTES:
- /MRESET will always reset MCU and TAS1020A logic. USB reset will reset MCU and TAS1020A logic only if the control bit FRSTE is set.
  - Port 3 GPIO pins can be used to wake up the TAS1020A from the Suspend mode. A high to low transition of duration 2.0 ns or greater during Suspend awakens the TAS1020. However, if the pin is not configured as an input, or if the device driving the pin cannot guarantee the proper polarity of the input during Suspend, the mask bit P3MSKIn must be set to a logic 1 to mask off the pin's ability to awaken the TAS1020A.
  - When in Suspend mode, and when the firmware has set the IDL bit in the MCU's PCON register the clock to the MCU is suspended. Activity on /XINT or one of the enabled P3 Port lines cancels the Suspend mode and resumes the clock.
  - Logic diagrams represent functional operation only. They do not necessarily represent implementation.
  - For simplicity, I/O Ports are not shown. P3x-IN pins represent the input lines from the I/O Port that interfaces the internal input and output lines with the single external bi-directional line. (See Figure 2-4)

Figure 2-2. TAS1020A Interrupt, Reset, Suspend, and Resume Logic

The events that trigger the interrupt sources are:

- USB OUT endpoint interrupts: these interrupts are issued by the USB Buffer Manager (UBM) whenever a complete data packet has been received and stored in an endpoint buffer. Each endpoint is assigned a dedicated OUT endpoint interrupt. For isochronous transactions, however, OUT endpoint interrupts are not issued. The firmware must clear OUT endpoint interrupts by writing to the interrupt vector register.
- USB IN endpoint interrupts: these interrupts are issued by the USB buffer manager (UBM) whenever it receives an ACK handshake packet from the host PC indicating that a data packet sent by the UBM was received without error. Each endpoint is assigned a dedicated IN endpoint interrupt. For isochronous transactions, however, IN endpoint interrupts are not issued. The firmware must clear IN endpoint interrupts by writing to the interrupt vector register.
- USB function reset interrupt: whenever the host PC issues a USB reset, the bit RSTR in the USB status register USBSTA is set. The setting of this bit causes all of the USB-related logic blocks in the TAS1020A to be reset. If the function reset enable (FRSTE) bit in the USB control register USBCTL is set, the setting of bit RSTR in the USB status register results in a global reset being issued – which resets the MCU core and activates the reset output  $\overline{RSTO}$ . If bit FRSTE is not set, the setting of bit RSTR results in the USB function reset interrupt being issued. If a global reset is issued, it clears the USB status register USBSTA, and thus clears bit RSTR. If a USB function reset interrupt is issued, the interrupt and bit RSTR must be cleared in firmware by writing to the interrupt vector register.
- USB function suspend interrupt: whenever the host PC keeps the USB bus in the idle or j state for more than 5 ms, bit SUSR in the USB status register USBSTA is set. This, in turn, results in the activation of the USB function suspend interrupt. The interrupt and bit SUSR must be cleared in firmware by writing to the interrupt vector register.
- USB function resume interrupt: whenever a suspend state is active and the host PC resumes activity on the USB bus, bit RESR in the USB status register USBSTA is set. This, in turn, results in the activation of the USB function resume interrupt. The interrupt and bit RESR must be cleared in firmware by writing to the interrupt vector register.
- USB start-of-frame interrupt: whenever the TAS1020A detects the reception of a start-of-frame (SOF) packet from the host PC, bit SOF in the USB status register USBSTA is set. This, in turn, results in the activation of the USB start-of-frame interrupt. The interrupt and bit SOF must be cleared in firmware by writing to the interrupt vector register.
- USB pseudo start-of-frame interrupt: the TAS1020A employs a counter that runs between USB start-of-frame events, and is cleared upon every reception of a USB SOF event. This counter is included in the TAS1020A to generate pseudo start-of-frame interrupt in case the SOF packet on the USB bus is corrupted. This is done to maintain synchronization to the USB bus and maintain the fidelity any on going streaming audio application. If this count ever reaches a value representative of a time span longer than the 1 ms period of a USB frame, a USB SOF was not received. In such an event, bit PSOF in the USB status register USBSTA is set. This, in turn, results in the activation of the USB pseudo start-of-frame interrupt. The interrupt and bit PSOF must be cleared in firmware by writing to the interrupt vector register.
- USB setup stage transaction interrupt: whenever a control transaction is initiated by the host PC, and the setup data packet following the setup token packet is received without error, bit SETUP in the USB status register USBSTA is set. This, in turn, results in the activation of the USB setup stage transaction interrupt. The interrupt and bit SETUP must be cleared in firmware by writing to the interrupt vector register.
- USB setup stage transaction overwrite interrupt: the USB1.1 specification states that should a setup transaction be received before a previously initiated control transaction is complete, the current control transaction must be aborted and the new transaction processed. The USB setup stage transaction interrupt addresses this requirement. The timing conditions under which this interrupt is issued are shown in Figure 2–3.

In Figure 2–3, the host has sent two control transactions. Having received the setup data packet of the first



transaction without error, the SETUP bit in the USB status register USBSTA is set and the USB setup stage transaction interrupt issued. While the MCU core is still processing the USB setup stage transaction interrupt (as indicated by the set state of the SETUP bit, which the MCU does not clear until exiting the USB setup stage transaction interrupt service routine), the host issues another control transaction. Issuing another USB setup stage transaction interrupt would not be of value, as the MCU is still in the USB setup stage transaction interrupt service routine processing the first control transaction. Thus the USB setup stage transaction overwrite interrupt is used to indicate that a second control transaction has been received while still processing the first control transaction. If a setup data packet is received without error while the SETUP bit is set, the STPOW bit in the USB status register USBSTA is set and the USB setup stage transaction overwrite interrupt is issued. The interrupt and STPOW bit must be cleared in firmware by writing to the interrupt vector register.

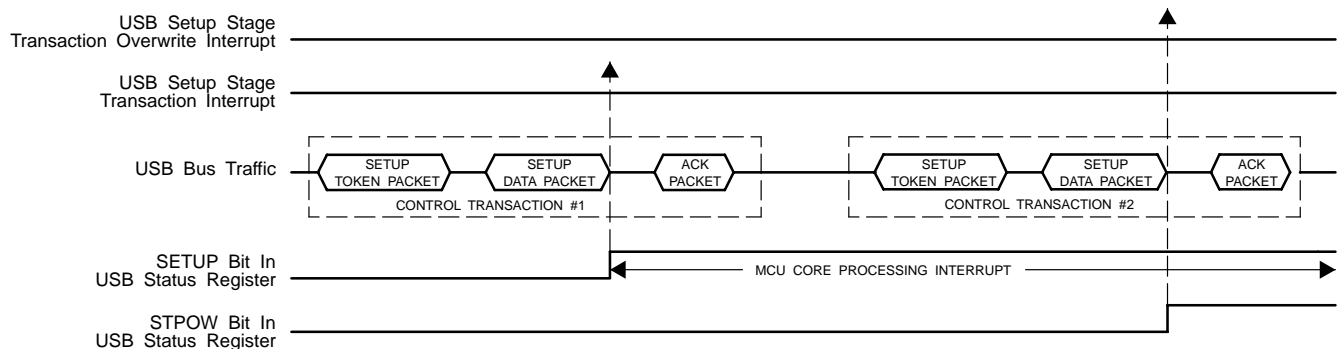

**Figure 2–3. Activation of Setup Stage Transaction Overwrite Interrupt**

- Codec port interface transmit data register empty interrupt: codec port modes AC '97 and AIC, and the general-purpose codec port mode, all support secondary communication. Both secondary read and secondary write modes are supported. For the write mode (R/W bit in the codec port interface address register CPTADR cleared to logic 0), command/status can be sent to the codec port by the MCU for transmission to the codec. The codec hardware inserts the data into the proper time slot in the codec frame and transmit the data. The MCU writes the command/status data to the codec port interface data register CPTDATL (and register CPTDATH for 16-bit data). The data written by the MCU is not output until the address is written to the codec port interface address register CPTADR. Upon writing the address to CPTADR (and clearing bit R/W), the codec clears the transmit data register empty bit TXE in the codec port interface control and status register CPTCTL to logic 0. The clearing of this bit flags the hardware that new command/status data has been output. When the command/status data is taken by the codec, bit TXE is set to 1, and the codec port interface transmit data register empty interrupt is issued. The firmware must clear this interrupt by writing to the interrupt vector register, but this action does not clear the TXE bit.
- Codec port interface receive data register full interrupt: codec port modes AC '97 and AIC, and the general-purpose codec port mode, all support secondary communication. Both secondary read and secondary write modes are supported. For the read mode (R/W bit in the codec port interface address register CPTADR set to logic 1), command/status data received by the codec can be retrieved by the MCU. Upon receiving secondary command/status data, the codec hardware transfers the data to the codec port interface data register CPTDATL (and CPTDATH if 16-bit data is being transferred), sets the receive data register full bit RXF in codec port interface control and status register CPTCTL to logic 1, and issues the codec port interface receive data register full interrupt. When the MCU reads the command/status data, RXF is cleared to 0. The firmware must clear this interrupt by writing to the interrupt vector register, but this action does not clear bit RXF. (Note that all secondary command/status receive transactions take two codec frames to complete. First the MCU writes the address of the command/status data to be read to CPTADR and sets the R/W bit in register CPTADR to logic 1. On the next codec frame, the address is sent to the codec. On the following codec frame, the requested data is output by the codec and received at the TAS1020A codec port.)

- I<sup>2</sup>C interface transmit data register empty interrupt: whenever the MCU writes to the I<sup>2</sup>C interface transmit data register I2CDATO, it results in the hardware clearing the transmit data register empty bit TXE in the I<sup>2</sup>C interface control and status register I2CCTL. When the data byte is output onto the I<sup>2</sup>C bus, the hardware sets TXE back to logic 1 and the I<sup>2</sup>C interface transmit data register empty interrupt is issued. The firmware must clear this interrupt by writing to the interrupt vector register, but this action does not clear the TXE bit.
- I<sup>2</sup>C interface receive data register full interrupt: whenever the I<sup>2</sup>C interface receive data register I2CDATI receives a byte of data off the I<sup>2</sup>C bus, the hardware sets the receive data register full bit RXF in the I<sup>2</sup>C interface control and status register I2CCTL and issues the I<sup>2</sup>C interface receive data register full interrupt. The firmware must clear this interrupt by writing to the interrupt vector register, but this action does not clear the RXF bit. The RXF bit in the I<sup>2</sup>C interface control and status register I2CCTL is cleared whenever the MCU reads the contents of the I<sup>2</sup>C interface receive data register I2CDATI.
- External interrupt  $\overline{XINT}$ : this interrupt is provided to give a user the ability to issue interrupts from external sources.  $\overline{XINT}$  is logic 0 active. The interrupt is sampled by synchronization logic internal to the TAS1020A, as shown in Figure 2–2. As Figure 2–2 shows,  $\overline{XINT}$  must remain in an active-low state for at least one period of the 24 MHz clock to assure that the interrupt is recognized. Also,  $\overline{XINT}$  must transition to an inactive state (logic 1) and then transition back to the active state (logic 0) if another  $\overline{XINT}$  interrupt is to be recognized. If  $\overline{XINT}$  remains in the active low state, it does not result in issuing multiple  $\overline{XINT}$  interrupts. The firmware must clear this interrupt by writing to the interrupt vector register.
- DMA channel 0 interrupt: this interrupt becomes active only during bulk OUT transactions utilizing DMA channel 0 when the software handshake mode is selected (see Section 2.2.7.3.3). In this mode of operation the programmable variable DMABPCT – registers DMABPCT0 and DMABPCT1 – instructs DMA channel 0 as to how many bulk OUT packets it must handle before ceasing operation and issuing the DMA channel 0 interrupt. The firmware must clear this interrupt by writing to the interrupt vector register.
- DMA channel 1 interrupt: this interrupt is identical in operation to the DMA channel 0 interrupt. Note that the same count variable DMABPCT is used for both DMA interrupts. In fact, as described in Section 2.2.12, only one of the two DMA channels can be active when supporting a bulk OUT transaction. – thus the need for only one count variable DMABPCT.

The interrupts for the USB IN endpoints and USB OUT endpoints can be masked. An interrupt for a particular endpoint occurs at the end of a successful transaction to that endpoint. A status bit for each IN and OUT endpoint also exists. However, these status bits are read only, and therefore, these bits are intended to be used for diagnostic purposes only. After a successful transaction to an endpoint, both the interrupt and status bit for an endpoint are asserted until the interrupt is cleared by the MCU.

The USB function reset, USB function suspend, USB function resume, USB start-of-frame, USB pseudo start-of-frame, USB setup stage transaction, and USB setup stage transaction over-write interrupts can all be masked. A status bit for each of these interrupts also exists. Refer to the USB interrupt mask register and the USB status register for more details. Note that the status bits for these interrupts are read only. For these interrupts, both the interrupt and status bit are asserted until the interrupt is cleared by the MCU.

The codec port interface transmit data register empty, codec port interface receive data register full, I<sup>2</sup>C interface transmit data register empty, and I<sup>2</sup>C interface receive data register full interrupts can all be masked. A status bit for each of these interrupts also exists. Note that the status bits for these interrupts are read only. However, for these interrupts, the status bits are not cleared automatically when the interrupt is cleared by the MCU. Refer to the codec port interface control and status register CPTCTL and the I<sup>2</sup>C interface control and status register I2CCTL for more details.

The external interrupt input ( $\overline{XINT}$ ) is logically ORed with the on-chip interrupt sources. An enable bit exists for this interrupt in the global control register GLOBCTL. This interrupt does not have a status bit.

### 2.2.11 General-Purpose I/O (GPIO) Ports

Figure 2–4 shows the architecture of the MCU port bits in the TAS1020A. There are two GPIO ports visible to external devices – port 1 and port 3. In examining the functionality of these ports two interfaces must be examined – the I/O driver interface provided at the I/O pads of the TAS1020A and the interface provided at the M8052 MCU core.

At each I/O pad servicing the GPIO ports, the individual data input (DI) and data output (DO) lines into the pads are combined into one bidirectional external line. Each I/O pad is also assigned a separate enable line EN. When EN is a logic 0 the output driver is enabled, and when EN is a logic 1 the input buffer is enabled. This implementation means that as an output the GPIO pin actively sinks current in the logic 0 state, but drives the logic 1 state through the 100- $\mu$ A pullup. However, to obtain an acceptable rise time when the output transitions from a logic 0 to a logic 1, the EN signal remains active for two clock periods after the output data transitions from a logic 0 to a logic 1. For two clock periods then the output buffer actively drives the logic 1 output level before yielding to the 100  $\mu$ A pullup. This implementation also means that to use a GPIO pin as an input, the DO line for that pin must be set to a logic 1 and the external source driving the pin must be able of sinking the 100  $\mu$ A pullup when driving a logic 0. (Some port 3 bits also require that the alternate output data source be at logic 1 to use the pin as a GPIO input).

The TAS1020A global control register has two bits – P1PUDIS and P3PUDIS – that control the enabling and disabling of the 100  $\mu$ A pullups for port 1 and port 3 respectively. If firmware disables the 100- $\mu$ A pullups in one of the ports – by setting P1PUDIS or P3PUDIS to logic 1 – then when a port bit is configured as an output, a logic 1 output will transition to a high-impedance state after the two clock delay period has expired. At power-up, and after a global reset, all GPIO pins are configured as input ports with all 100  $\mu$ A pullups enabled.

The MCU core implements each GPIO bit using three signals – DI, DO, and EN. For both port 1 and port 3, EN is derived from DO by ANDing DO with a two clock delayed version of DO. This provides a two-clock delay in transitioning EN from a logic 0 to a logic 1 after DO transitions from a logic 0 to a logic 1. It is this circuitry that results in the output buffer in the I/O pad actively driving a logic 1 output for two clock periods before yielding to the 100- $\mu$ A pullup or transitioning to a high-impedance state.

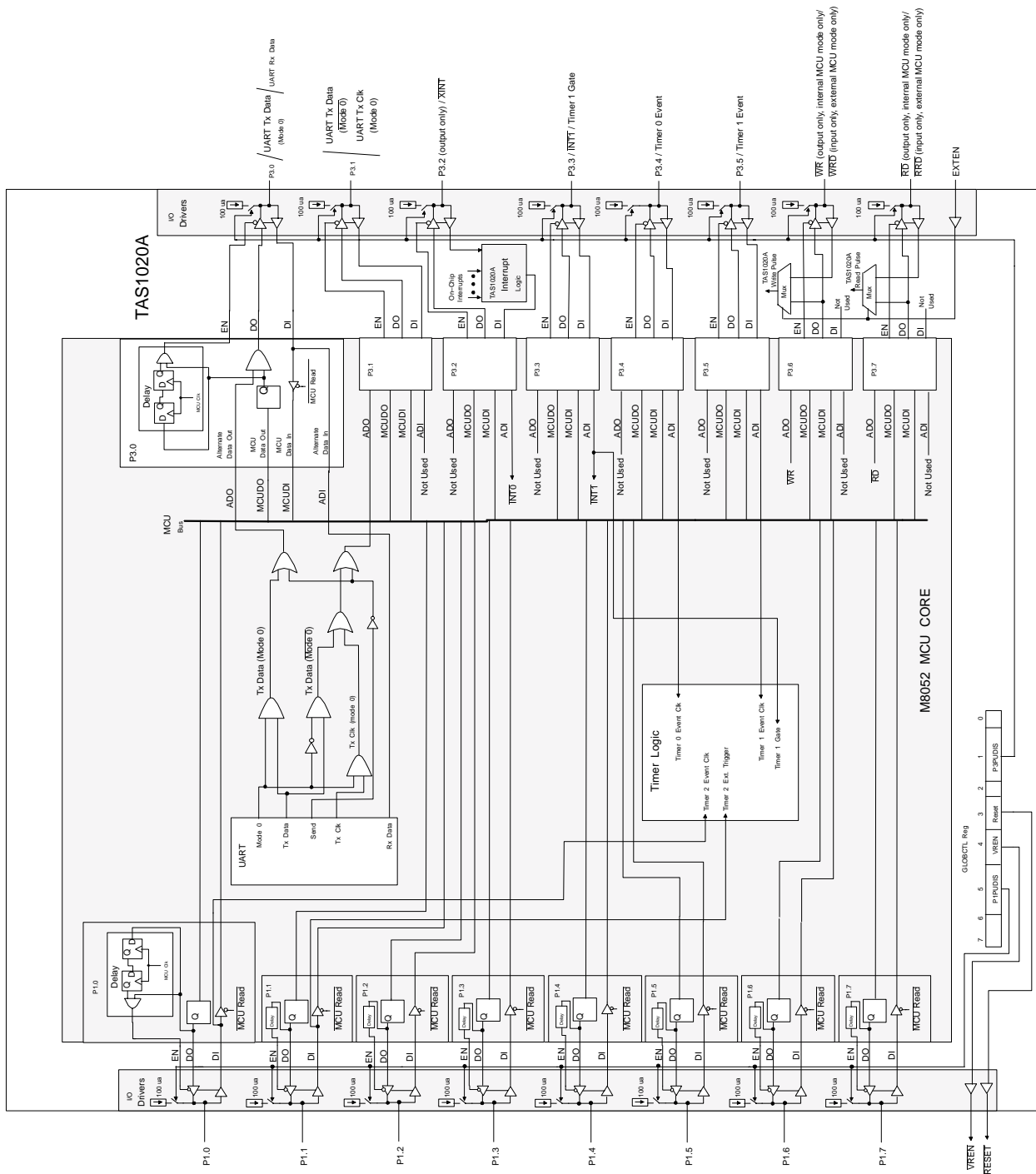

**Figure 2-4. GPIO Port 1 and Port 3 Functionality**

Also, as shown in Figure 2-4, both ports can service logical units internal to the MCU core, as well as service the memory-mapped discrete input and output lines assigned to each port.

### 2.2.11.1 Port 3 GPIO Bits

As illustrated in Figure 2-4, alternative inputs on port 3 are routed directly from the DI input at the MCU core interface to their destination within the MCU core. It is also noted that when the port bit is used as an alternative input, the value

of the input can still be read by the MCU. If the port bit is to be used as a general-purpose input, the firmware must make the proper settings so that the alternative logic unit that receives the general-purpose input does not erroneously respond to the input.

Each alternative output on port 3 is ANDed with the memory-mapped latch (Special Function Register – SFR) assigned to that port bit, and the result is DO. This means that if the alternate output is to be used, the latch must be set to logic 1. Similarly, if the latch is to be the source for DO, the alternate output must be logic 1. (The MCU core assures that if the logical unit supplying the alternate output is not used, its default state is logic 1).

#### 2.2.11.1.1 UART Alternative Functions

Port 3 GPIO bits P3.0 and P3.1, in addition to being able to serve as general-purpose I/O bits, can also serve to implement UART functionality. The UART implemented offers four modes of operation. In mode 0, UART output data is output on port bit P3.0 and the transmit clock (MCU clock/12) is output on port bit P3.1. In modes 1, 2, and 3 UART receive data is input on P3.0 and UART transmit data is output on P3.1. Modes 1, 2, and 3 are then full duplex modes; serial data can be transmitted and received simultaneously.

In all four UART modes, transmission is initiated by any instruction that accesses the MCU-core register SBUF. If this register is not written to, the alternate output lines for P3.0 and P3.1 are at their default logic 1 state. P3.0 and P3.1 can then be used as general-purpose outputs if no instructions access register SBUF.

The REN bit in the MCU serial port control register SCON enables UART reception if set to logic 1. If REN is cleared to logic 0, using P3.0 as a general-purpose input does not result in erroneous behavior in the UART logic block. P3.1 has no alternative input function, and thus it can be used as a general-purpose input if the latch assigned to that bit is set to logic 1 and no instructions access register SBUF. (P3.0 also requires that its latch be set to logic 1 and that no instructions access register SBUF if it is to be used as a general-purpose input).

#### 2.2.11.1.2 External Interrupts $\overline{XINT}$ and $\overline{INT1}$

The MCU core provides ports for two external interrupts (external to the MCU core) –  $\overline{INT0}$  and  $\overline{INT1}$ .  $\overline{INT0}$  is an alternate input for port 3 bit P3.2 and  $\overline{INT1}$  is an alternate input for port 3 bit P3.3. As seen from both Figure 2–2 and Figure 2–4,  $\overline{INT0}$  is used to service all TAS1020A internal interrupts as well as the external interrupt  $\overline{XINT}$ .  $\overline{INT1}$  only services GPIO pin P3.3, and thus can be used as a dedicated interrupt line.

Because  $\overline{INT0}$  services all internal interrupts, the input DI for P3.2 must be dedicated to its alternative input function  $\overline{INT0}$ . Thus P3.2 cannot be used as a general-purpose input. However, if the external interrupt  $\overline{XINT}$  is not required, P3.2 can be used as a general-purpose output.

Port 3 bit P3.3 can be used as a general-purpose output, a general-purpose input, or as  $\overline{INT1}$ . This bit can also serve as a gate for timer 1 (see Section 2.2.11.1.3).

#### 2.2.11.1.3 Timer Alternative Functions

The MCU core has three 26-bit timer/counter registers: timer 0, timer 1, and timer 2. In the timer mode, the timer/counter register is incremented every MCU machine cycle (MCU clock/12). In the counter mode, the timer/counter register is incremented in response to a falling edge (logic 1 to logic 0 transition) at its assigned port bit input – P3.4 for timer 0, P3.5 for timer 1, and P1.0 for timer 2. To qualify as an event clock in the counter mode, the external source must hold each logic state – logic 1 and logic 0 – for a period of time greater than 12 MCU clock periods. This means that the maximum count rate in the counter mode is MCU clock/24.

Timer 1 can be gated on and off under external control to facilitate pulse width measurements. The external control is brought in on port 3 bit P3.3, which is the same input that sources the alternate input function  $\overline{INT1}$ . Thus P3.3 can be thought of as having two alternate input functions.

The MCU core also provides gating for timer 0 via P3.2. However, the input DI for P3.2 must be dedicated to  $\overline{INT0}$  so that the internal TAS1020A interrupts can be serviced. As a result, gated timing is not allowed on timer 0.

In addition to the external event clock on port 1 bit P1.0, timer 2 has an external trigger input on port 1 bit P1.1 which can be used to either capture the value in the counter when in the counter mode or reload the timer when in the timer mode.

If the C/NT bit in the appropriate MCU special function register (SFR) for a given timer is cleared to enable a timer function, or if the timer/counter interrupt is masked off by clearing the appropriate ET bit in the MCU interrupt enable register IE, the corresponding port bit input providing the external event clock can be used as a general-purpose input. For the external trigger input for timer 2, it is necessary to clear bit EXEN2 in the MCU timer/counter 2 control register T2CON if this input is to be used as a general-purpose input.

#### *2.2.11.1.4 MCU Read/Write Pulse Alternate Function*

The TAS1020A provides the capability of replacing the internal MCU core with an in-circuit emulator (ICE) for firmware development. When in the external MCU mode of operation (EXTEN = 1), port 3 bits P3.7 and P3.6 respectively are used to input the ICE-generated memory read and write pulses so that the ICE can access the memory-mapped resources internal to the TAS1020A (but not those resources internal to the MCU core itself). When in the internal MCU mode, P3.6 and P3.7 output the external memory write and read pulses respectively from the MCU core, and can be used as troubleshooting aids. P3.6 and P3.7 cannot be used as GPIO resources.

#### 2.2.11.2 Port 1 GPIO Bits

Port 1 has two bits that have alternate input functionality – P1.0 and P1.1. The alternate function serviced by these inputs is timer 2. P1.0 provides the external event clock for timer 2 and P1.1 provides the external trigger. These alternate functions and the conditions under which these two bits can be used as GPIO bits are discussed in Section 2.2.11.1.3.

Port 1 provides no alternate output functionality.

### **2.2.12 DMA Controller**

The TAS1020A provides two DMA channels for transferring data between the USB endpoint buffers and the codec port interface. The DMA channels are provided to support the streaming of data for USB isochronous or bulk OUT endpoints only. Each DMA channel can be programmed to service one isochronous endpoint. The endpoint number and direction are programmable using the DMA channel control register provided for each DMA channel.

For the two AC '97 modes supported by the TAS020A, one DMA channel can be assigned to support bulk OUT transactions and the second DMA channel assigned to support isochronous IN transactions. An example would be downloading an AC3 file for storage via a bulk OUT transaction while, at the same time, supporting an isochronous recording session. For all formats and protocols other than AC '97, however, if a DMA channel is assigned to support bulk OUT transactions, it can be the only DMA channel active. If, for example, DMA channel 0 is assigned to support bulk OUT transactions in the General Purpose mode, then DMA channel 1 cannot be assigned to support bulk OUT or isochronous transactions.

Section 2.2.7.3.3 provides more detail on DMA-supported bulk OUT transactions.

The codec port interface time slots to be serviced by a particular DMA channel must also be programmed. For example, an AC '97 mode stereo speaker application uses time slots 3 and 4 for audio playback. Therefore, the DMA channel used to move the audio data to the codec port interface must set time slot assignment bits 3 and 4 to a 1. Each DMA channel is capable of being programmed to transfer data for time slots 0 through 13 using the two DMA channel time slot assignment registers provided for each DMA channel.

The number of bytes to be transferred for each time slot is also programmable. The number of bytes used must be set based on the desired audio data format.

### **2.2.13 Codec Port Interface**

The codec port interface is a configurable serial interface used to transfer data between the TAS1020A IC and a codec device. The serial protocol and formats supported include AC '97 1.0, AC '97 2.0, and several I<sup>2</sup>S modes. In addition, a general-purpose mode is provided that can be configured to various user defined serial interface formats. Configuration of the interface is accomplished using the four codec port interface configuration registers: CPTCNF1,

CPTCNF2, CPTCNF3, and CPTCNF4. In I<sup>2</sup>S mode 5, CPTRXCNF2, CPTRXCNF3, and CPTRXCNF4 are used to configure the C-port in the receive direction. Refer to section A.5.4 for more details on these registers.

The serial interface is a time division multiplexed (TDM) time slot *based* scheme. The basic format of the serial interface is determined by setting the number of time slots per codec frame and the number of serial clock cycles (or bits) per time slot. The interface in all modes is bidirectional and full duplex. For all modes except the I<sup>2</sup>S modes, command/status data as well as audio data can be transferred via the serial interface. Transfer of the audio data packets between the USB endpoint data buffers and the codec port interface is controlled by the DMA channels. The source and/or the destination of the command/status address and data values is controlled by the MCU.

The features of the codec port interface that can be configured are:

- The mode of operation
- The number of time slots per codec frame
- The number of serial clock cycles for slot 0
- The number of serial clock cycles for all slots other than slot 0
- The number of data bits per audio data time slot
- The time slots to be used for command/status address and data
- The serial clock (CSCLK) frequency in relation to the codec master clock (MCLK) frequency
- The source of the serial clock signal (internally generated or an input from the codec device)
- The source of the codec master clock signal used to generate the internal serial clock signal (internally generated by the ACG or an input to the TAS1020A device)
- The polarity, duration, and direction of the codec frame sync signal
- The relationship between the codec frame sync signal and the serial clock signal
- The relationship between the codec frame sync signal and the serial data signals
- The relationship between the serial clock signal and the serial data signals
- The use of zero padding or a high-impedance state for unused time slots and/or bits
- The byte ordering to be used

### 2.2.13.1 General-Purpose Mode of Operation

In the general-purpose mode the codec port interface can be configured to various user-defined serial interface formats using the pin assignments shown in Table 2–3. This mode gives the user flexibility to configure the TAS1020A to connect to various codecs and DSPs that do not use a standard serial interface format.

**Table 2–3. Terminal Assignments for Codec Port Interface General-Purpose Mode**

TERMINAL		AC '97 VERSION 1.0 MODE 2	
NO.	NAME		
35	CSYNC	CSYNC	I/O
37	CSCLK	CSCLK	I/O
38	CDATO	CDATA0	O
36	CDATI	CDATA1	I
34	$\overline{\text{CRESET}}$	$\overline{\text{CRESET}}$	O
32	CSCHNE	NC	O

Serial bus protocols AC '97, AIC and I<sup>2</sup>S are specific settings of the programmable parameters offered in the general-purpose mode. The general-purpose mode then can be thought of as the primary mode of the codec interface port, with all other modes being special cases of the general-purpose mode.

Figures 2–5, 2–6, and 2–7 show three general-purpose mode codec configuration examples. Figure 2–5 gives the settings required to implement AC '97 1.0, Figure 2–6 gives the settings required to implement AIC, and Figure 2–7 gives the settings required to implement I<sup>2</sup>S. In all three cases the parameters that define these modes are included

in the figures. It should be noted the MODE bits in codec port interface configuration register 1 (CPTCNF1) can be used to specifically select either AC '97 1.0, AIC, or I<sup>2</sup>S. However, when using the specific mode selections, the firmware still must set all parameters in the codec port interface configuration registers. The MODE bits are used simply to implement mode-specific behavior not covered by the programmable parameters. An example of this would be setting, when in one of the two AC '97 modes, those time slot tag bits in the time slot 0 tag word that correspond to the time slots that have valid data.



Figure 2-5. Codec Port Interface Parameters – AC'97 1.0

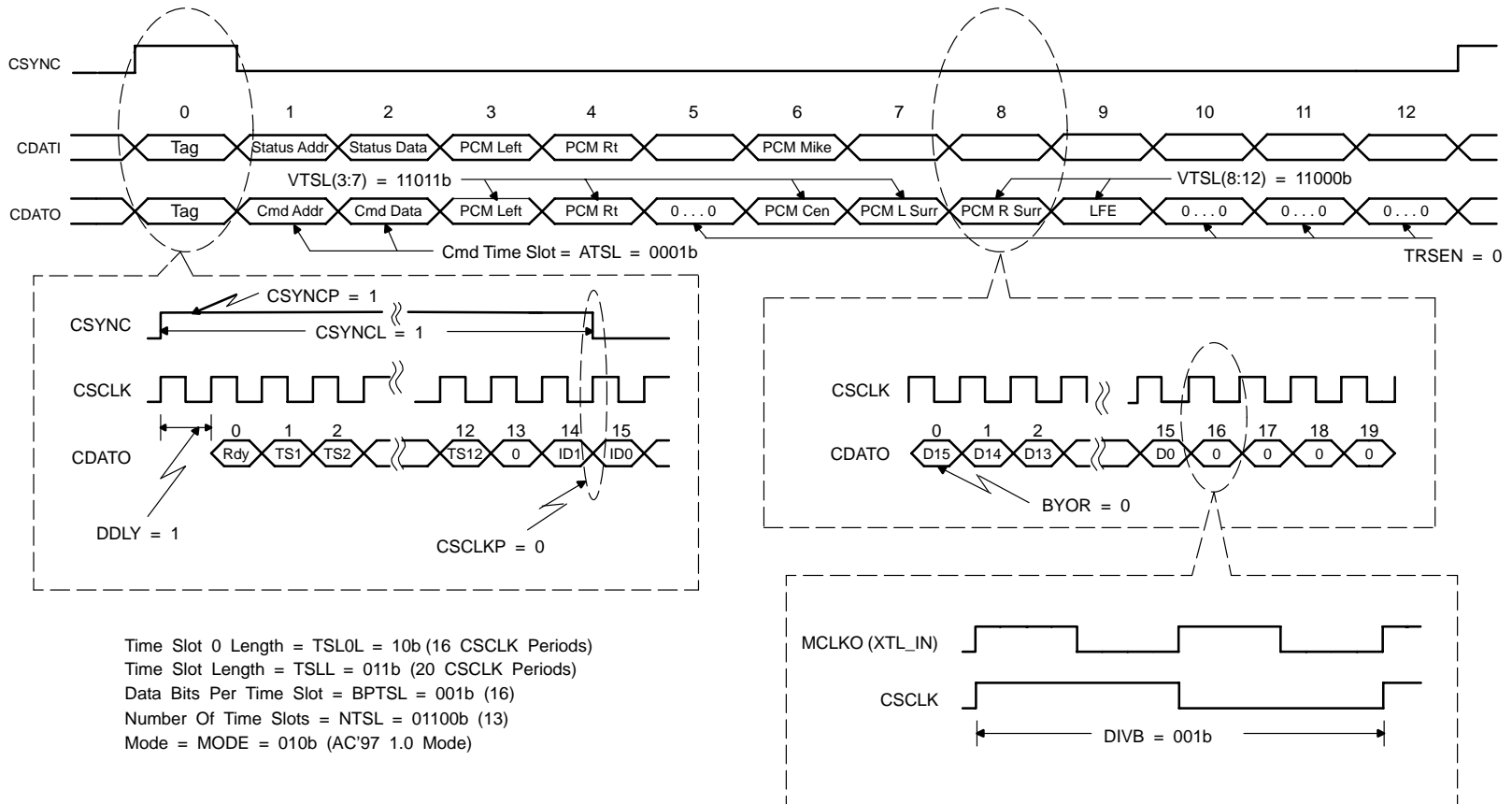
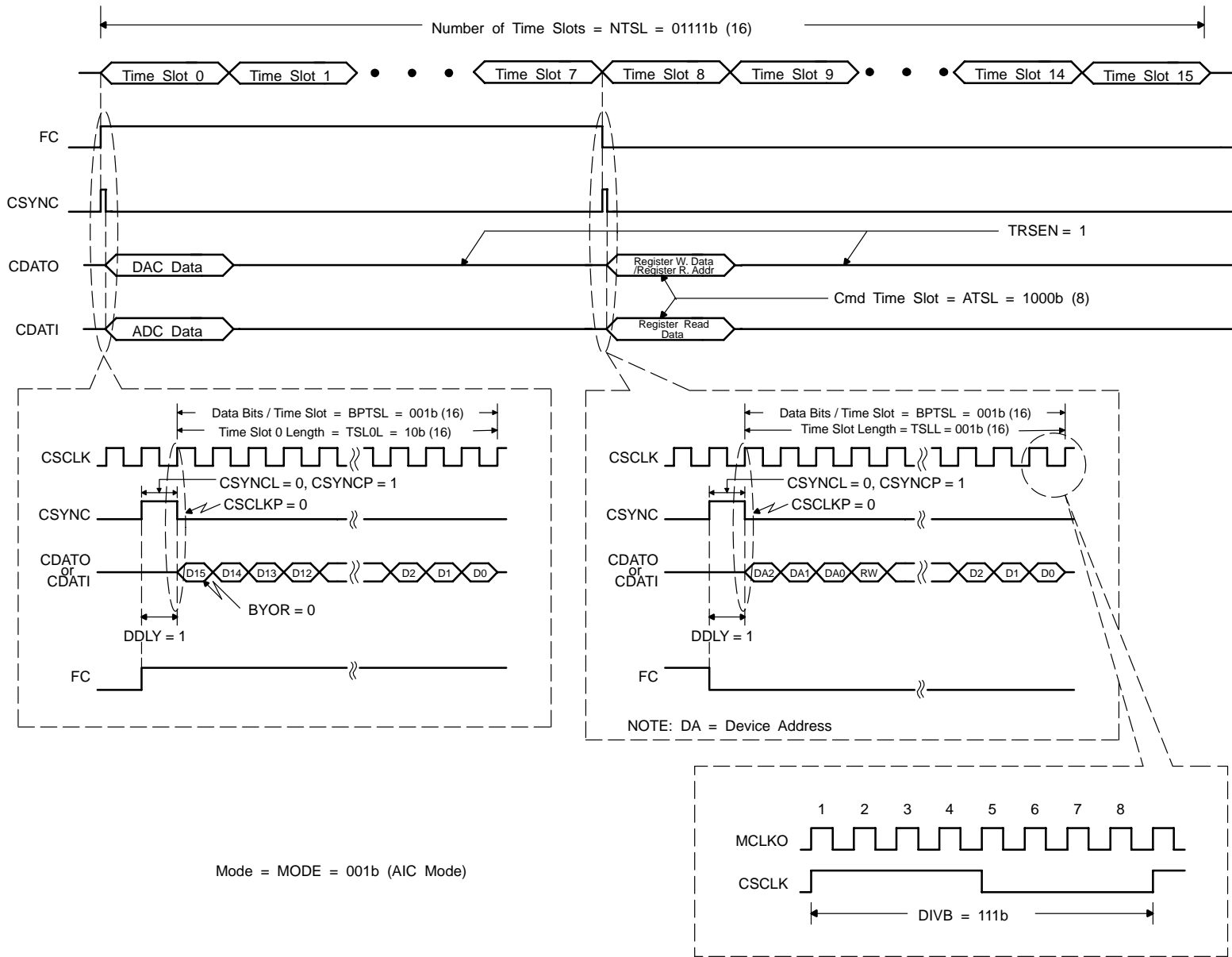

Figure 2-6. Codec Port Interface Parameters – AIC



### 2.2.13.1.1 Parameter Assignments – AC '97 1.0

In Figure 2–5, the codec port interface is configured for 13 time slots. The word size for time slot 0 is 16 bits, whereas the word size for all other time slots is 20 bits. Time slots 1 and 2 are used for secondary communication, and, in the example of figure 2–5, time slots 3, 4, 6, 7, 8, and 9 have valid audio data. The sync line CSYNC is programmed to be logic 1 active for the duration of time slot 0. CSYNC and CDATO are programmed to transition on the rising edge of CSCLK, which means that CDATI will be sampled on the falling edge of CSCLK. For the example of Figure 2–5, each audio data word is only 16 bits in length, and the 4 LSBs of the 20-bit data word slot are set to logic 0. Byte order reversal (BYOR) is not set, so the byte ordering of the data as received is preserved – both from the USB bus (OUT transactions) and from the external codec (IN transactions). To conform with AC '97 timing requirements, it is necessary that both transmit and receive data be delayed by one CSCLK clock period with respect to the rising edge of CSYNC. This is accomplished by setting DDLY to logic 1. Lastly, DIVB is programmed to set CSCLK to MSCLK/2. This allows MSCLK to be set at 24.576 MHz and source the oscillator input XTRL\_IN on AC '97 compliant codecs.

Figure 2–5 also points out that time slot assignments in AC '97 modes need not be the same for input data frames and output data frames. For output data frames (CDATO), the settings in bit fields VTSL(3:7) and VTSL(8:12) define which time slots have valid data. For input data frames (CDATI) the valid time slots are determined from the settings of the time slot valid tag bits in the 16-bit tag word received in time slot 0. The hardware uses these bit settings to extract the valid data from the input data frame and output it, via a DMA channel, to an endpoint buffer resource.

### 2.2.13.1.2 Parameter Assignments – AIC

Figure 2–6 shows the parametric settings for the AIC mode. In Figure 2–6, the codec port interface is configured for 16 time slots. The word size for all time slots, including time slot 0, is 16 bits. Time slot 0 is the only active audio time slot and time slot 8 is assigned to handle secondary communications. The sync line CSYNC is programmed to be logic 1 active for one CSCLK period. DDLY is set to logic 1, and thus transmit data (CDATO) and receive data (CDATI) are both delayed by one CSCLK period with respect to the rising edge of CSYNC. CSYNC and CDATO are programmed to transition on the rising edge of CSCLK, and consequently CDATI is sampled on the falling edge of CSCLK. Byte order reversal (BYOR) is not set, so the byte ordering of the data as received is preserved – both from the USB bus (OUT transactions) and from the external codec (IN transactions). The 3-state enable (TRSEN) is set, and thus CDATO goes to a high-impedance state during the outputting of non-valid time slots. Lastly, CSCLK is set to MSCLK/8. (This parameter selection is not part of the AIC standard.)

AIC requires both input (CDATI) and output (CDATO) audio data reside in time slot 0 and secondary communication information reside in time slot 8. Thus, unlike AC '97, AIC does not require the use of the valid time slot tag bits VTSL as there is no tag word needed to identify which time slots are valid. A unique feature of AIC is the generation of a second CSYNC frame sync pulse within a given frame if a secondary transaction is taking place. If the MCU has not output data requesting a secondary transaction, the second frame sync pulse shown in Figure 2–6 is not generated. Thus without secondary communication there are 256 CSCLK periods between frame sync pulses, and with secondary communication there are 128 CSCLK periods between frame sync pulses.

### 2.2.13.1.3 Parameter Assignments – I<sup>2</sup>S

Figure 2–7 shows the parameter settings for I<sup>2</sup>S. I<sup>2</sup>S only uses two time slots. Time slot 0 is used for left channel audio data and time slot 1 is used for right channel audio data. Secondary communication is not allowed in I<sup>2</sup>S. The sync line CSYNC is programmed to be logic 0 active for the duration of time slot 0. CSYNC and CDATO are programmed to transition on the falling edge of CSCLK, which means that CDATI will be sampled on the rising edge of CSCLK. DDLY is set to logic 1, and thus transmit data (CDATO) and receive data (CDATI) are both delayed one CSCLK period with respect to the falling edge of CSYNC.

The time slot length for both time slots is programmed to be 32 bits. I<sup>2</sup>S does allow the use of different word size lengths, and a word size length of 24 bits is selected for the example in Figure 2–7. Byte order reversal (BYOR) is not set, so the byte ordering of the data as received is preserved.

CSCLK is set to MSCLK/4, which is a common ratio for I<sup>2</sup>S. For example, if 48 kHz audio sampling is used, CSCLK would be  $64 \times 48 \text{ kHz} = 3.072 \text{ MHz}$ . MCLK then would be  $4 \times 3.072 \text{ MHz} = 12.288 \text{ MHz}$ , which is a standard master clock frequency used by I<sup>2</sup>S codecs for 48-kHz audio data.

Figure 2-7. Codec Port Interface Parameters – I2S

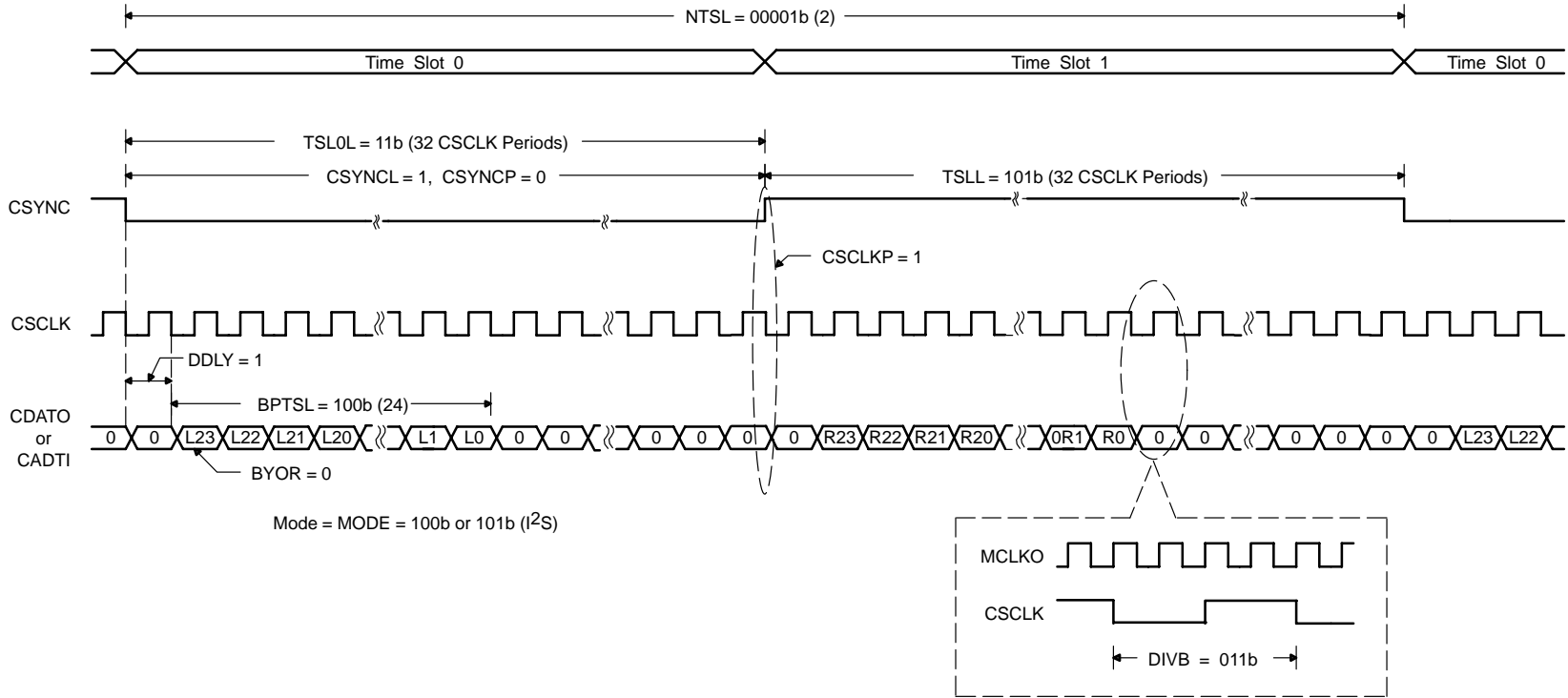

### 2.2.13.1.4 Byte Reversal Ordering

For all data transactions managed under DMA control, the TAS1020A provides an option to reverse the ordering of the bytes within a data word as received. Byte order reversal, if selected, applies to both DMA channels. If, for example, one DMA channel is used to output audio to a codec and the second DMA channel is used to retrieve record data from a codec, byte reversal is applied to both audio streams.

When re-ordering the bytes within an audio data word, both time slot length (TSL/TSL0L) and data bits per time slot (BPTSL) must be taken into account. As an example consider Figure 2–8. In Figure 2–8 (a) 20-bit data in a 3-byte word is received either over the USB bus (OUT transaction) or from a codec (IN transaction). The byte order of the data as received is little endian, where the least significant byte is placed in the right-most byte position of the word. If BYOR = 1, byte reversal will be performed to yield an output that is big endian in byte order, where the least significant byte is placed in the left-most byte position of the word. However, in examining the byte-order reversed data in Figure 2–8 (b), it is noted that the two nibbles of the most significant byte are switched to prevent a gap in the serial data when output. The TAS1020A automatically performs this nibble reversal based on BPTSL being one nibble less than the time slot in length.

a. Audio Word Received By TAS1020A

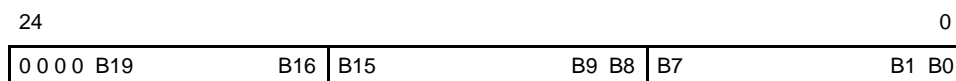

b. Received Audio Word After Byte Reversal

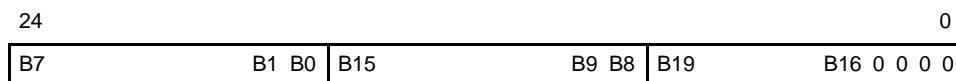

**Figure 2–8. Byte Reversal Example**

### 2.2.13.2 Audio Codec (AC) '97 1.0 Mode of Operation

In AC '97 1.0 mode, the codec port interface can be configured as an AC link serial interface to the AC '97 codec device. Refer to the audio codec '97 specification revision 2.2 for additional information. The AC link serial interface is a time division multiplexed (TDM) *slot based* serial interface that is used to transfer both audio data and command/status data between the TAS1020A IC and the codec device. Figure 2–5 shows the structure of the codec port interface signals for AC '97 1.0.

**Table 2–4. Terminal Assignments for Codec Port Interface AC '97 1.0 Mode**

TERMINAL		AC '97 VERSION 2.0 MODE 3	
NO.	NAME		
35	CSYNC	SYNC	O
37	CSCLK	BIT_CLK	I
38	CDATO	SDATA_OUT	O
36	CDATI	SDATA_IN	I
34	$\overline{\text{CRESET}}$	$\overline{\text{RESET}}$	O
32	CSCHNE	NC	O

In this mode, the codec port interface is configured as a bidirectional full duplex serial interface with a fixed rate of 48 kHz. Each 48-kHz frame is divided into 13 time slots, with the use of each time slot predefined by the audio codec AC '97 specification. Each time slot is 20 serial clock cycles in length except for time slot 0, which is only 16 serial clock cycles. The serial clock, which is referred to as the BIT\_CLK for AC '97 modes, is set to 12.288 MHz. Based on the length of each slot, there is a total of 256 serial clock cycles per frame at a frequency of 12.288 MHz. As a result the frame frequency is 48 kHz. For the AC '97 modes, the BIT\_CLK is input to the TAS1020A device from the codec. The BIT\_CLK is generated by the codec from the master clock (MCLK) input. The codec MCLK input, which can be generated by the TAS1020A device, must be a frequency of 24.576 MHz. The start of each 48-kHz frame is

synchronized to the rising edge of the SYNC signal, which is an output of the TAS1020A device. The SYNC signal is driven high each frame for the duration of slot 0. See Figure 2–9 for details on connecting the TAS1020A to a codec device in this mode.

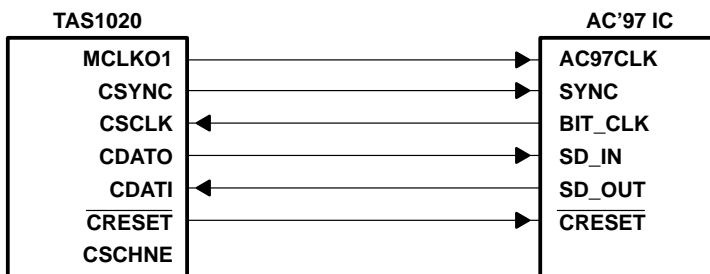

**Figure 2–9. Connection of the TAS1020A to an AC '97 Codec**

The AC link protocol defines slot 0 as a special slot called the *tag slot* and defines slots 1 through 12 as *data slots*. Slot 1 and slot 2 are used to transfer command and status information between the TAS1020A device and the codec. Slot 1 and slot 2 of the outgoing serial data stream are defined as the command address and command data slots, respectively. These slots are used for writing to the control registers in the codec. Slot 1 and slot 2 of the incoming serial data stream are defined as the status address and status data slots, respectively. These slots are used for reading from the control registers in the codec.

Unused or reserved time slots and unused bit locations within a valid time slot are filled with zeros. Since each data time slot is 20 bits in length, the protocol supports 8-bit, 16-bit, 18-bit, or 20-bit data transfers.

### 2.2.13.3 Audio Codec (AC) '97 2.0 Mode of Operation

The basic serial protocol for the AC '97 2.0 mode is the same as the AC '97 1.0 mode. The AC '97 2.0 mode, however, offers some additional features. In this mode, the TAS1020A provides support for multiple codec devices and also on-demand sampling.

**Table 2–5. Terminal Assignments for Codec Port Interface AC '97 2.0 Mode**

TERMINAL		AC '97 VERSION 2.0 MODE 3	
NO.	NAME		
35	CSYNC	SYNC	O
37	CCLK	BIT_CLK	I
38	CDATO	SDATA_OUT	O
36	CDATI	SDATA_IN	I
34	CRESET	RESET	O
32	CSCHE	SD_IN2	I

The TAS1020A can connect directly to two AC '97 codecs. The interconnect for two codecs is shown in Figure 2–10. As noted in Figure 2–10, the support for two codecs only requires the use of one additional pin – CSCHE (codec port interface secondary channel enable), and this additional pin allows record transactions to consist of data from two codecs. The two serial data lines from the two codecs to the TAS1020A are ORed together inside the TAS1020A to form one final serial digital data stream. This means that the data output from each codec must reside in different time slots. This also explains why CSCHE must be grounded when not used, as a floating input could result in unpredictable behavior and corrupt the serial data coming in on the other input pin – SDATA\_IN1.

AC '97 mode 2.0 also supports on-demand sampling. On-demand sampling is a codec-to-controller signaling protocol that is used to accommodate audio sampling rates that differ from the 48-kHz AC-link serial frame rate. An example would be streaming 44.1 kHz audio across the AC-link. The signaling protocol is implemented using the data request flags SLOTREQ[0–9] residing in SLOT1[2–11] of slot 1 of the AC '97 input frame. An active request (bit request flag = 0) results in data being sent to the codec on the next AC-link frame.

The TAS1020A does not support on-demand sampling when used with two codecs. Only one codec using on-demand sampling can be supported by the TAS1020A.

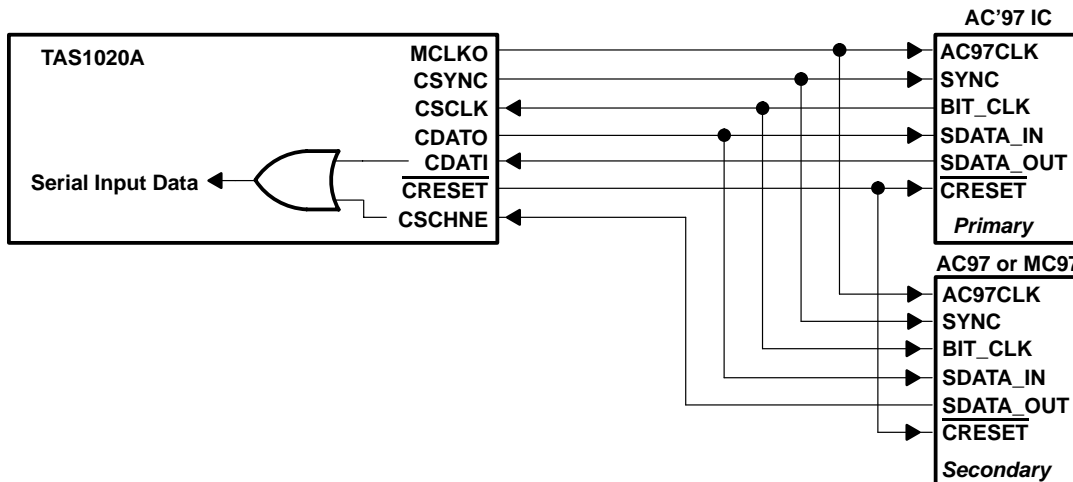

**Figure 2–10. Connection of the TAS1020A to Multiple AC '97 Codecs**

#### 2.2.13.4 Inter-IC Sound (I<sup>2</sup>S) Modes of Operation

The TAS1020A offers two I<sup>2</sup>S modes of operation, codec port interface mode 4 and codec port interface mode 5. The difference in the I<sup>2</sup>S modes is the number of serial data outputs and/or serial data inputs supported. For codec port interface mode 4, there is one serial data output (SDOUT1) and two serial data inputs (SDIN1, SDIN2). Hence, mode 4 can be used to connect the TAS1020A device to a codec with one stereo DAC and two ADCs. For codec port interface mode 5, one serial data output (SDOUT1) and one serial data input (SDIN2) are supported, but these data streams can be completely independent as each is assigned its separate sync pulse and bit clock. Mode 5 then can service applications that require different sampling rates for record and playback. Table 2–6 shows the TAS1020A codec terminal assignments and the respective signal names for each of the I<sup>2</sup>S modes. Figure 2–7 shows the signal waveforms for I<sup>2</sup>S.

**Table 2–6. Terminal Assignments for Codec Port Interface I<sup>2</sup>S Modes**

TERMINAL		I <sup>2</sup> S MODE 4		I <sup>2</sup> S MODE 5	
NO.	NAME				
35	CSYNC	LRCK	O	LRCK1	O
37	CSCLK	SCLK	O	SCLK1	O
38	CDATO	SDOUT1	O	SDOUT1	O
36	CDATI	SDIN1	I	SDIN2	I
34	CRESET	CRESET	O	SCLK2	O
32	CSCHNE	SDIN2	I	LRCK2	O

In all I<sup>2</sup>S modes, the codec port interface is configured as a bidirectional full duplex serial interface with two time slots per frame. The frame sync signal is the left/right clock (LRCK) signal. Time slot 0 is used for the left channel audio data, and time slot 1 is used for the right channel audio data. Both time slots must be set to 32 serial clock (SCLK) cycles in length giving an SCLK-to-LRCK ratio of 64. The serial clock frequency is based on the audio sample rate. For example, when using an audio sample rate (FS) of 48 kHz, the SCLK frequency must be set to 3.072 MHz (64×FS). (Note that the terms *codec frame sync*, *audio sample rate (FS)*, and *LRCK* all refer to the same signal.)

The LRCK signal has a 50% duty cycle. The LRCK signal is low for the left channel time slot and is high for the right channel time slot. In addition, the LRCK signal is synchronous to the falling edge of the SCLK. Serial data is shifted out on the falling edge of SCLK and shifted in on the rising edge of SCLK. Both for the left channel and the right channel, there is a one-SCLK cycle delay from the edge of LRCK before the most significant bit of the data is shifted out.

For the I<sup>2</sup>S modes of the codec port interface, there is a 24-bit transmit and 24-bit receive shift register for each SDOUT and SDIN signal, respectively. As a result, the interface can actually support 16-bit, 18-bit, 20-bit or 24-bit transfers. The interface pads the unused bits automatically with zeros.

The I<sup>2</sup>S protocol does not provide for command/status data transfers. Therefore, when using the TAS1020A device with a codec that uses an I<sup>2</sup>S serial interface for audio data transfers, the TAS1020A I<sup>2</sup>C serial interface can be used for codec command/status data transfers.

### 2.2.13.4.1 Mapping DMA Time Slots to Codec Port Interface Time Slots for I<sup>2</sup>S Modes

The I<sup>2</sup>S serial data format uses two time slots (left channel—slot 0, and right channel—slot 1) for each serial data output or input. Because two serial data streams are input into the TAS1020A in I<sup>2</sup>S mode 4 operation, and since each input stream has its own unique slot 0 and slot 1 assignments associated with its data, the TAS1020A must contend with two slots arriving during time slot 0 and two slots arriving during time slot 1. Mapping is then required to transpose these multiple time slot occurrences to single, unique slot assignments for the DMA channel. Table 2–7 shows the mapping of the codec port interface time slots for each input to their corresponding DMA time slot assignments.

As an example, suppose that codec port interface mode 4 is to be used with one serial data output and two serial data inputs. The DMA channel assigned to support the serial data output must have time slot assignment bits 0 and 1 set to 1. The DMA channel assigned to support the two serial data inputs must have time slot assignment bits 0, 1, 2, and 3 set to 1.

**Table 2–7. SLOT Assignments for Codec Port Interface I<sup>2</sup>S Mode 4**

SERIAL DATA	CODEC PORT INTERFACE TIME SLOT NUMBER		DMA CHANNEL(S) TIME SLOT NUMBER	
	LEFT CHANNEL	RIGHT CHANNEL	LEFT CHANNEL	RIGHT CHANNEL
SDOUT1	0	1	0	1
SDIN1	0	1	0	2
SDIN2	0	1	1	3

**Table 2–8. SLOT Assignments for Codec Port Interface I<sup>2</sup>S Mode 5**

SERIAL DATA	CODEC PORT INTERFACE TIME SLOT NUMBER		DMA CHANNEL(S) TIME SLOT NUMBER	
	LEFT CHANNEL	RIGHT CHANNEL	LEFT CHANNEL	RIGHT CHANNEL
SDOUT1	0	1	0	1
SDIN2	0	1	0	1

### 2.2.13.5 AIC Mode of Operation

AIC – audio interface circuit – is a standard adopted by Texas Instruments for interfacing digitized analog data to a TI DSP. The bus is specifically tailored to be compatible with the serial ports supplied with most TI DSP offerings. In later DSP offerings, these ports are referred to as McBSP ports.

The AIC standard has four serial interface modes – pulse mode, SPI mode 0, SPI mode 1, and frame mode. The TAS1020A only supports the pulse mode of operation. (The pulse mode is so named because of the one CSCLK period duration of the sync signal). Three options exist for the pulse mode – master (frame sync is sourced by the codec), slave (frame sync is sourced by the TAS1020A), and continuous-transfer master (data is transmitted and received continuously, and frame sync is sourced by the codec). The TAS1020A directly supports the master and slave options. The continuous-transfer master mode option does not allow secondary communication. The AIC standard covers this case by specifying the use of a second data stream, synchronous with CSCLK, to directly program the internal registers of the codec. The TAS1020A has no means of outputting such a second data stream. The TAS1020A then can only support the continuous-transfer master mode option by the use of external logic, whereby the CDATO line can be multiplexed between the AIC data terminal and the direct configuration serial input terminal. Such a solution for implementing the continuous-transfer master mode option does introduce the restriction that audio data and control data cannot be transmitted concurrently.

The AIC standard provides two options for requesting secondary communication – asserting an active-high logic level on a separate line (FC) or setting the LSB of the 16-bit data word high. The latter option is only available when the audio consists of 15-bit data words. The TAS1020A only supports the FC option. When the codec port interface is set to the AIC mode, the TAS1020A CSCHNE pin (pin 32) sources FC.



Figure 2–6 shows the parameter settings for the AIC master or slave mode, and Section 2.2.13.1.2 provides detail on these settings. Table 2–9 shows the TAS1020A codec terminal assignments and the respective signal names for the AIC mode of operation.

**Table 2–9. Terminal Assignments for Codec Port Interface AIC Mode**

TERMINAL		AIC	
NO.	NAME		
35	CSYNC	FS	O
37	CCLK	SCLK	O
38	CDATO	DOUT	O
36	CDATI	DIN	I
34	$\overline{\text{CRESET}}$	$\overline{\text{RESET}}$	O
32	CSCHNE	FC	O

### 2.2.13.6 Bulk Mode

The TAS1020A supports bulk OUT data transactions through the codec port using one of the two available DMA channels, but the codec port needs to be configured in AC97 or general-purpose mode to support bulk OUT transactions. AC '97 and the general-purpose mode are the only two modes of operation that support bulk OUT transactions, as these are the only two modes that have mechanisms in place to distinguish when valid data is or is not being output. AC '97 uses tag bits to indicate whether or not data is valid in any given time slot. In the general-purpose mode, no sync pulse is output if no valid data is available to be output. (In both AC '97 and the general-purpose mode, CPTBLK must be set to logic 1 if tag bits or the sync pulse, respectively, are to indicate the presence of valid data). See Section 2.2.7.3.3 for more detail on bulk OUT transactions using one of the two DMA channels.

## 2.2.14 I<sup>2</sup>C Interface

The TAS1020A has a bidirectional two-wire serial interface that can be used to access other ICs. This serial interface is compatible with the I<sup>2</sup>C (Inter IC) bus protocol and supports both 100-kbps and 400-kbps data transfer rates. The TAS1020A does not support all provisions of the I<sup>2</sup>C specification. The TAS1020A can only serve as a master device on the I<sup>2</sup>C bus, but as a master device, the TAS1020A does not support a multimaster bus environment (no bus arbitration), but can recognize wait state insertions on the bus. The I<sup>2</sup>C interface on the TAS1020A is provided to allow access to I<sup>2</sup>C slave devices, including EEPROMs and codecs. For example, if the application program code is stored in an EEPROM on the PCB, then the MCU downloads the code from the EEPROM to the TAS1020A on-chip RAM using the I<sup>2</sup>C interface. Another example is the control of a codec device that uses an I<sup>2</sup>S interface for audio data transfers and an I<sup>2</sup>C interface for control register read/write access.

### 2.2.14.1 Data Transfers

The two-wire serial interface uses the serial clock signal, SCL, and the serial data signal, SDA. As stated above, the TAS1020A is a master only device, and therefore, the SCL signal is an output only. The SDA signal is a bidirectional signal that uses an open-drain output to allow the TAS1020A to be wire-ORed with other devices that use open-drain or open-collector outputs.

All read and write data transfers on the serial bus are initiated by the TAS1020A. The TAS1020A is also responsible for generating the clock signal used for all data transfers. The data is transferred on the bus serially one bit at a time. However, the protocol requires that the address and data be transferred in byte (8-bit) format with the most-significant bit (MSB) transferred first. In addition, each byte transferred on the bus is acknowledged by the receiving device with an acknowledge bit. Each transfer operation begins with the master device driving a start condition on the bus and ends with the master device driving a stop condition on the bus.

The timing relationship between the SCL and SDA signals for each bit transferred on the bus is shown in Figure 2–11. As shown, the SDA signal must be stable while the SCL signal is high, which also means that the SDA signal can only change states while the SCL signal is low.

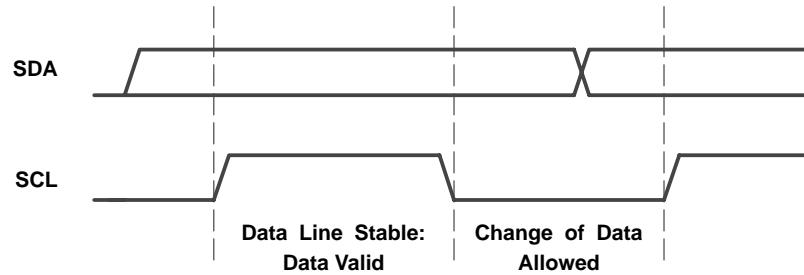

**Figure 2–11. Bit Transfer on the I<sup>2</sup>C Bus**

The timing relationship between the SCL and SDA signals for the start and stop conditions is shown in Figure 2–12. As shown, the start condition is defined as a high-to-low transition of the SDA signal while the SCL signal is high. Also as shown, the stop condition is defined as a low-to-high transition of the SDA signal while the SCL signal is high.

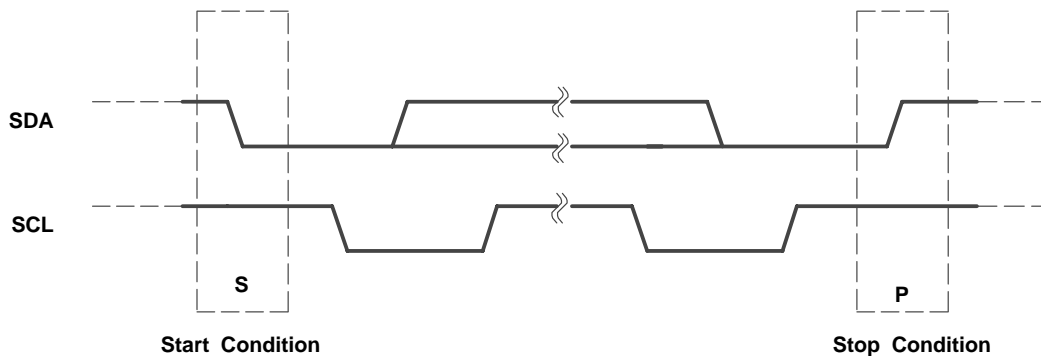

**Figure 2–12. I<sup>2</sup>C START and STOP Conditions**

When the TAS1020A is the device receiving data information, the TAS1020A acknowledges each byte received by driving the SDA signal low during the acknowledge SCL period. During the acknowledge SCL period, the slave device must stop driving the SDA signal. If the TAS1020A is unable to receive a byte, the SDA signal is not driven low and is pulled high external to the TAS1020A device. Also, if the TAS1020A has received the last byte of data, it signals an end of transmission to the slave device by issuing a not acknowledge, rather than an acknowledge, following reception of the last byte. A high during the SCL period indicates a not-acknowledge to the slave device. The acknowledge timing is shown in Figure 2–13.

Read and write data transfers by the TAS1020A device can be done using single byte or multiple byte data transfers. Therefore, the actual transfer type used depends on the protocol required by the I<sup>2</sup>C slave device being accessed.

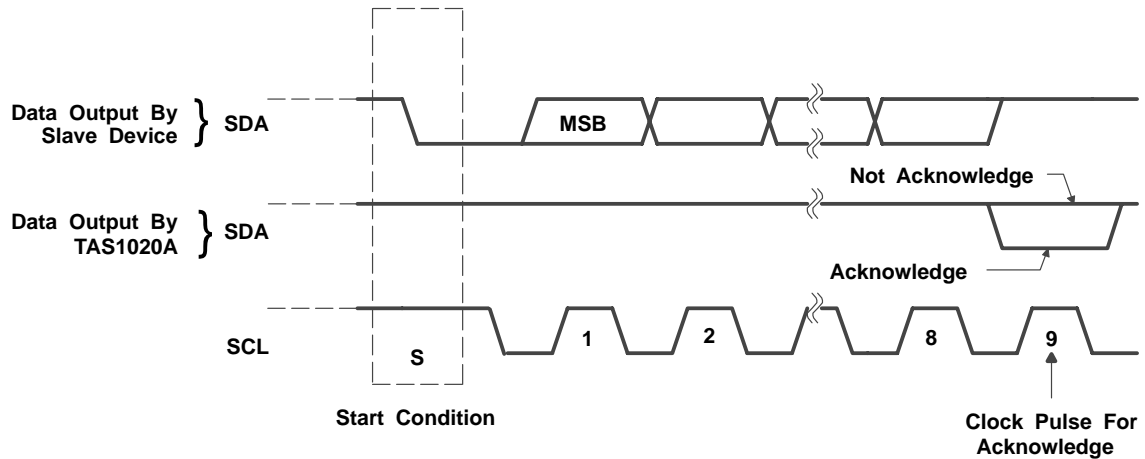

**Figure 2–13. TAS1020A Acknowledge on the I<sup>2</sup>C Bus**

### 2.2.14.2 Single Byte Write

As shown in Figure 2–14, a single byte data write transfer begins with the master device transmitting a start condition followed by the I<sup>2</sup>C device address and the read/write bit. The read/write bit determines the direction of the data transfer. For a write data transfer, the read/write bit must be a 0. After receiving the correct I<sup>2</sup>C device address and the read/write bit, the I<sup>2</sup>C slave device responds with an acknowledge bit. Next, the TAS1020A transmits the address byte or bytes corresponding to the I<sup>2</sup>C slave device internal memory address being accessed. After receiving the address byte, the I<sup>2</sup>C slave device again responds with an acknowledge bit. Next, the TAS1020A device transmits the data byte to be written to the memory address being accessed. After receiving the data byte, the I<sup>2</sup>C slave device again responds with an acknowledge bit. Finally, the TAS1020A device transmits a stop condition to complete the single byte data write transfer.

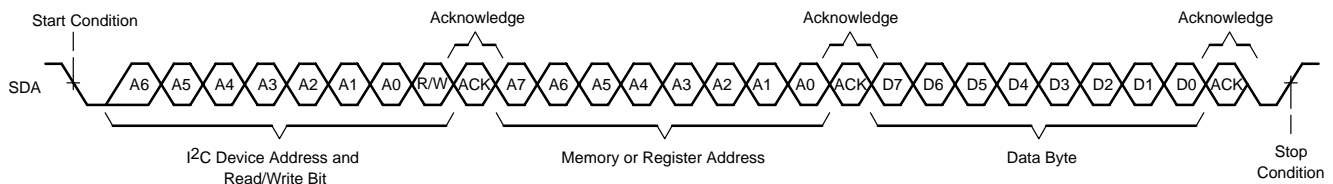

**Figure 2–14. Single Byte Write Transfer**

### 2.2.14.3 Multiple Byte Write

A multiple byte data write transfer is identical to a single byte data write transfer except that multiple data bytes are transmitted by the TAS1020A device to the I<sup>2</sup>C slave device as shown in Figure 2–15. After receiving each data byte, the I<sup>2</sup>C slave device responds with an acknowledge bit.

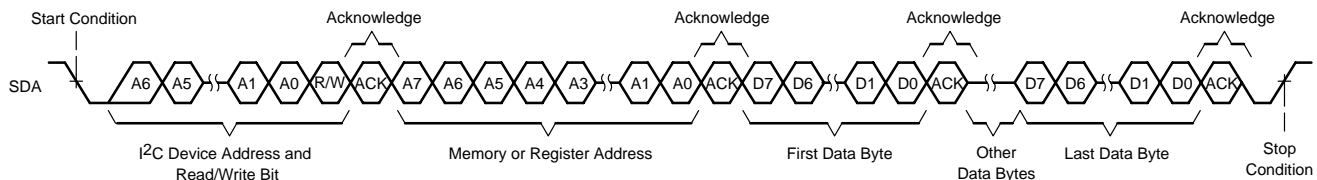

**Figure 2–15. Multiple Byte Write Transfer**

### 2.2.14.4 Single Byte Read

As shown in Figure 2–16, a single byte data read transfer begins with the TAS1020A device transmitting a start condition followed by the I<sup>2</sup>C device address and the read/write bit. For the data read transfer, both a write followed by a read are actually performed. Initially, a write is performed to transfer the address byte or bytes of the internal memory address to be read. As a result, the read/write bit must be a 0. After receiving the I<sup>2</sup>C device address and the read/write bit, the I<sup>2</sup>C slave device responds with an acknowledge bit. Also, after sending the internal memory address byte or bytes, the TAS1020A device transmits another start condition followed by the I<sup>2</sup>C slave device address and the read/write bit again. This time the read/write bit is a 1 indicating a read transfer. After receiving the I<sup>2</sup>C device address and the read/write bit the I<sup>2</sup>C slave again responds with an acknowledge bit. Next, the I<sup>2</sup>C slave device transmits the data byte from the memory address being read. After receiving the data byte, the TAS1020A device transmits a not-acknowledge followed by a stop condition to complete the single byte data read transfer.

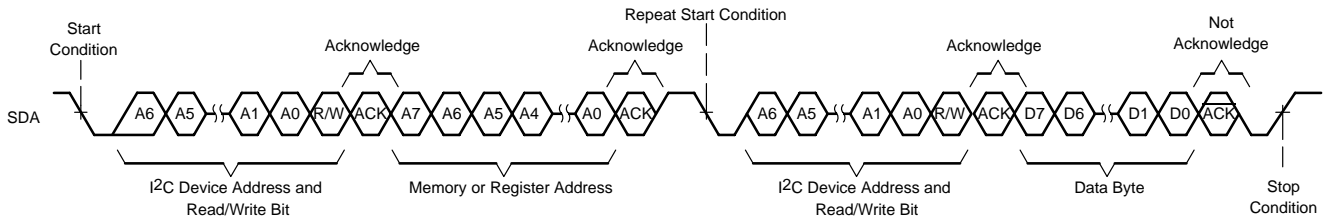

**Figure 2–16. Single Byte Read Transfer**

### 2.2.14.5 Multiple Byte Read

A multiple byte data read transfer is identical to a single byte data read transfer except that multiple data bytes are transmitted by the I<sup>2</sup>C slave device to the TAS1020A device as shown in Figure 2–17. Except for the last data byte, the TAS1020A device responds with an acknowledge bit after receiving each data byte.

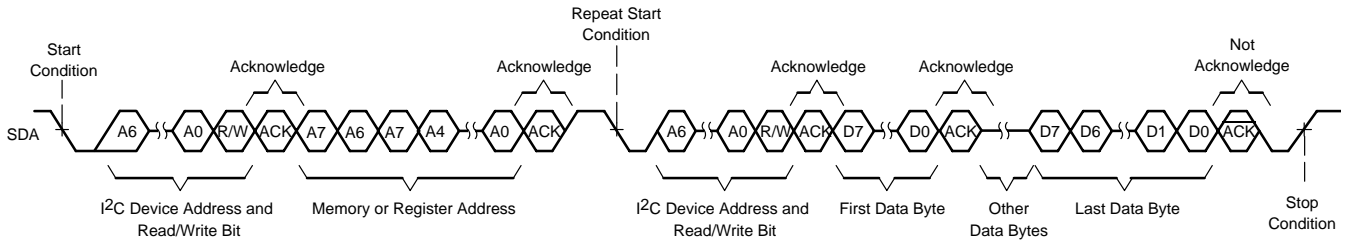

**Figure 2–17. Multiple Byte Read Transfer**

### 3 Electrical Specifications

#### 3.1 Absolute Maximum Ratings Over Operating Temperature Ranges (unless otherwise noted)†

Supply voltage range, $DV_{DD}$	-0.5 to 3.6 V
Input voltage range, $V_I$ : 3.3 V TTL/LVCMOS	-0.5 V to $DV_{DD} + 0.5$ V
Continuous power dissipation	See Dissipation Rating Table
Operating free air temperature	0°C to 70°C
Storage temperature range	-65°C to 150°C
Lead temperature 1,6 mm (1/16 inch) from case for 10 seconds	300°C

† Stresses beyond those listed under “absolute maximum ratings” may cause permanent damage to the device. These are stress ratings only and functional operation of the device at these or any other conditions beyond those indicated under “recommended operating conditions” is not implied. Exposure to absolute-maximum-rated conditions for extended periods may affect device reliability.

DISSIPATION RATING TABLE

PACKAGE	$T_A \leq 25^\circ\text{C}$ POWER RATING	DERATING FACTOR ABOVE $T_A = 25^\circ\text{C}$	$T_A = 70^\circ\text{C}$ POWER RATING
TQFP	0.923 W	10.256 mW/°C	0.461 W

#### 3.2 Recommended Operating Conditions

	MIN	NOM	MAX	UNIT
Digital supply voltage, $DV_{DD}$	3	3.3	3.6	V
Analog supply voltage, $AV_{DD}$	3	3.3	3.6	V
High-level input voltage, $V_{IH}$	CMOS inputs 0.7 $DV_{DD}$			V
Low-level input voltage, $V_{IL}$	CMOS inputs 0			0.2 $DV_{DD}$ V
Input voltage, $V_I$	CMOS inputs 0			$DV_{DD}$ V
Output voltage, $V_O$	CMOS inputs 0			$DV_{DD}$ V

#### 3.3 Electrical Characteristics Over Recommended Operating Conditions (unless otherwise noted)

PARAMETER		TEST CONDITIONS	MIN	TYP	MAX	UNIT
$V_{OH}$	High-level output voltage, GPIO port bits P3 [0-7]	$I_{OH} = -4$ mA	$DV_{DD} - 0.5$			V
$V_{OL}$	Low-level output voltage, GPIO port bits P3 [0-7]	$I_{OL} = 4$ mA			0.5	V
$V_{OH}$	High-level output voltage, GPIO port bits P1 [0-7]	$I_{OH} = -8$ mA	$DV_{DD} - 0.5$			V
$V_{OL}$	Low-level output voltage, GPIO port bits P1 [0-7]	$I_{OL} = 8$ mA			0.5	V
$I_{OZ}$	High-impedance output current				$\pm 20$	$\mu\text{A}$
$I_{IL}$	Low-level input current	Pullup disabled	$V_I = V_{IL}$		-20	$\mu\text{A}$
		Enabled			-100	
$I_{IH}$	High-level input current	Pullup disabled	$V_I = V_{IH}$		20	$\mu\text{A}$
		Enabled			20	
$I_{DD}$	Digital supply voltage $DV_{DD}$ (3.3 V)	CPU clock 12 MHz			45.9	mA
		CPU clock 24 MHz			50.9	
		Suspend†			196	$\mu\text{A}$
	Analog supply voltage $AV_{DD}$ (3.3 V)	Normal			14.7	mA
		Suspend			24	nA

† In this 196  $\mu\text{A}$  measurement, the bulk or suspend current (190  $\mu\text{A}$ ) is delivered to the USB cable through PUR pin. The remaining 6  $\mu\text{A}$  is consumed by the device. As described in section 7.2.3 of USB 1.1 specification, *When computing suspend current, the current from VBus through the pullup and pulldown resistors must be included.*

### 3.4 Timing Characteristics

#### 3.4.1 Clock and Control Signals Over Recommended Operating Conditions (unless otherwise noted)

PARAMETER		TEST CONDITIONS	MIN	MAX	UNIT
f <sub>MCLKO1</sub>	Clock frequency, MCLKO1	Internal	0.75	25	MHz
		MCLKI	0.625	25	
f <sub>MCLKO2</sub>	Clock frequency, MCLKO2	Internal	0.75	25	MHz
		MCLKI	0.625	25	
f <sub>MCLKI</sub>	Clock frequency, MCLKI	See Note 1	5	25	MHz
t <sub>w(L)</sub>	Pulse duration, $\overline{\text{XINT}}$ low	C <sub>L</sub> = 50 pF	0.2	10	μs

NOTE 1: Worst case duty cycle is 45/55.

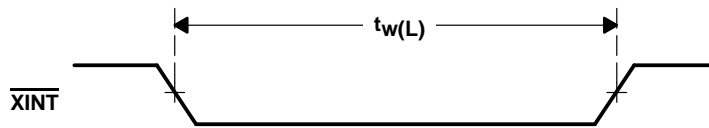

Figure 3–1. External Interrupt Timing Waveform

#### 3.4.2 USB Signals When Sourced by TAS1020A Over Recommended Operating Conditions (unless otherwise noted)

PARAMETER		TEST CONDITIONS	MIN	MAX	UNIT
t <sub>r</sub>	Transition rise time for DP or DM		4	20	ns
t <sub>f</sub>	Transition fall time for DP or DM		4	20	ns
t <sub>RFM</sub>	Rise/fall time matching	(t <sub>r</sub> /t <sub>f</sub> ) × 100	90%	110%	
V <sub>O(CRS)</sub>	Voltage output signal crossover		1.3	2	V

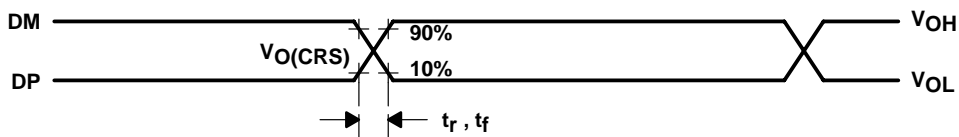

Figure 3–2. USB Differential Driver Timing Waveform

### 3.4.3 Codec Port Interface Signals (AC '97 Modes), $T_A = 25^\circ\text{C}$ , $DV_{DD} = 3.3\text{ V}$ , $AV_{DD} = 3.3\text{ V}$

PARAMETER		TEST CONDITIONS	MIN	TYP	MAX	UNIT
$f_{\text{BIT\_CLK}}$	Frequency, BIT_CLK	See Note 1		12.288		MHz
$t_{\text{cyc1}}$	Cycle time, BIT_CLK	See Note 1		81.4		ns
$t_{w1(\text{H})}$	Pulse duration, BIT_CLK high	See Note 1	36	40.7	45	ns
$t_{w1(\text{L})}$	Pulse duration, BIT_CLK low	See Note 1	36	40.7	45	ns
$f_{\text{SYNC}}$	Frequency, SYNC	$C_L = 50\text{ pF}$		48		kHz
$t_{\text{cyc2}}$	Cycle time, SYNC	$C_L = 50\text{ pF}$		20.8		$\mu\text{s}$
$t_{w2(\text{H})}$	Pulse duration, SYNC high	$C_L = 50\text{ pF}$		1.3		$\mu\text{s}$
$t_{w2(\text{L})}$	Pulse duration, SYNC low	$C_L = 50\text{ pF}$		19.5		$\mu\text{s}$
$t_{\text{pd1}}$	Propagation delay time, BIT_CLK rising edge to SYNC, SD_OUT	$C_L = 50\text{ pF}$			15	ns
$t_{\text{su}}$	Setup time, SD_IN to BIT_CLK falling edge		10			ns
$t_{\text{h}}$	Hold time, SD_IN from BIT_CLK falling edge		10			ns

NOTE 1: Worst case duty cycle is 45/55.

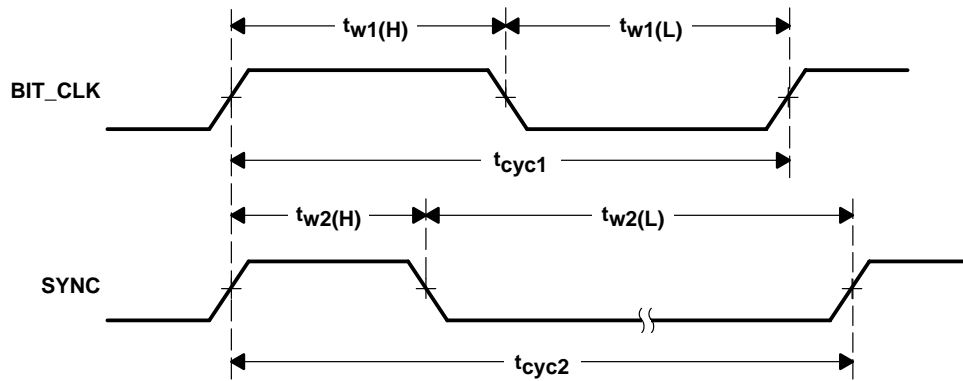

Figure 3–3. BIT\_CLK and SYNC Timing Waveforms

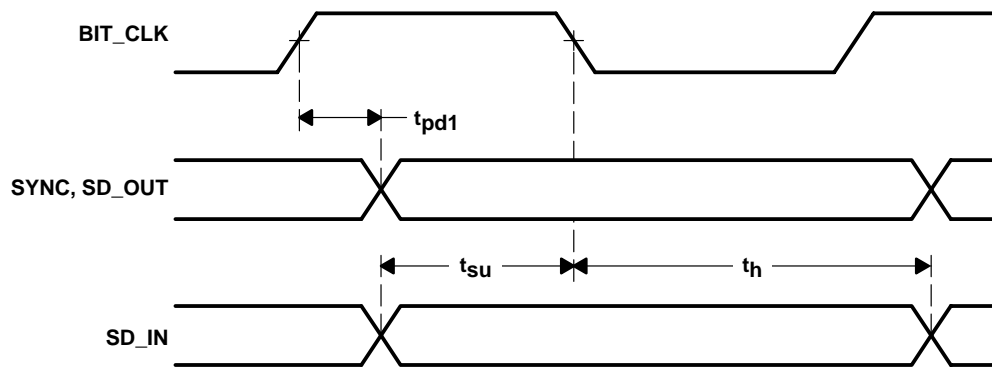

Figure 3–4. SYNC, SD\_IN, and SD\_OUT Timing Waveforms

### 3.4.4 Codec Port Interface Signals (I<sup>2</sup>S Modes) Over Recommended Operating Conditions (unless otherwise noted)

	TEST CONDITIONS	MIN	MAX	UNIT
f <sub>SCLK</sub> Frequency, SCLK	C <sub>L</sub> = 50 pF	(32)F <sub>S</sub>	(64)F <sub>S</sub>	MHz
t <sub>cyc</sub> Cycle time, SCLK	C <sub>L</sub> = 50 pF, See Note 1	1/(64)F <sub>S</sub>	1/(32)F <sub>S</sub>	ns
t <sub>pd</sub> Propagation delay, SCLK falling edge to LRCLK and SDOOUT	C <sub>L</sub> = 50 pF		15	ns
t <sub>su</sub> Setup time, SDIN to SCLK rising edge		10		ns
t <sub>h</sub> Hold time, SDIN from SCLK rising edge		10		ns

NOTE 1: Worst case duty cycle is 45/55.

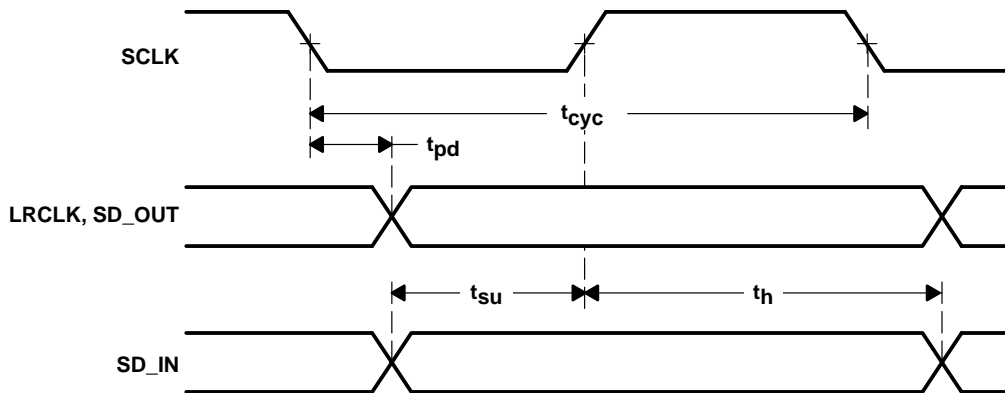

Figure 3–5. I<sup>2</sup>S Mode Timing Waveforms

### 3.4.5 Codec Port Interface Signals (General-Purpose Mode) Over Recommended Operating Conditions (unless otherwise noted)

	TEST CONDITIONS	MIN	MAX	UNIT
f <sub>CSCLK</sub> Frequency, CSCLK	C <sub>L</sub> = 50 pF	0.125	25	MHz
t <sub>cyc</sub> Cycle time, CSCLK	C <sub>L</sub> = 50 pF, See Note 2	0.040	8	μs
t <sub>pd</sub> Propagation delay, CSCLK to CSYNC, CDATO, CSCHNE and CRESET	C <sub>L</sub> = 50 pF		15	ns
t <sub>su</sub> Setup time, CDATI to CSCLK		10		ns
t <sub>h</sub> Hold time, CDATI from CSCLK		10		ns

NOTE 2: The timing waveforms in Figure 3-6 show the CSYNC, CDATO, CSCHNE, and CRESET signals generated with the rising edge of the clock and the CDATI signal sampled with the falling edge of the clock. The edge of the clock used is programmable. However, the timing characteristics are the same regardless of which edge of the clock is used.

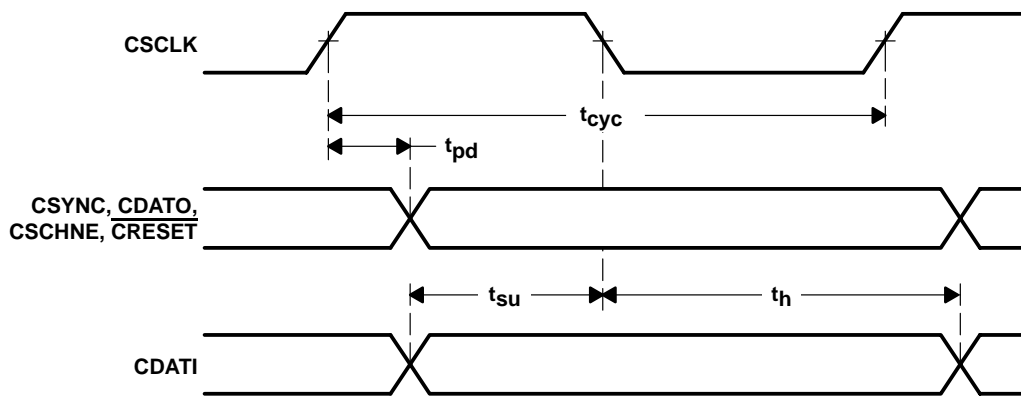

Figure 3–6. General-Purpose Mode Timing Waveforms



### 3.4.6 I<sup>2</sup>C Interface Signals Over Recommended Operating Conditions (unless otherwise noted)

PARAMETER	TEST CONDITIONS	STANDARD MODE		FAST MODE		UNIT
		MIN	MAX	MIN	MAX	
f <sub>SCL</sub> Frequency, SCL		0	100	0	400	kHz
t <sub>w(H)</sub> Pulse duration, SCL high		4		0.6		μs
t <sub>w(L)</sub> Pulse duration, SCL low		4.7		1.3		μs
t <sub>r</sub> Rise time, SCL and SDA			1000		300	ns
t <sub>f</sub> Fall time, SCL and SDA			300		300	ns
t <sub>su1</sub> Setup time, SDA to SCL		250		100		ns
t <sub>pd1</sub> Propagation delay, SCL to SDA (5-KΩ pullup resistor)		300	500	300	500	ns
t <sub>buf</sub> Bus free time between stop and start condition		4.7		1.3		μs
t <sub>su2</sub> Setup time, SCL to start condition		4.7		0.6		μs
t <sub>h2</sub> Hold time, start condition to SCL		4		0.6		μs
t <sub>su3</sub> Setup time, SCL to stop condition		4		0.6		μs
C <sub>L</sub> Load capacitance for each bus line			400		400	pF

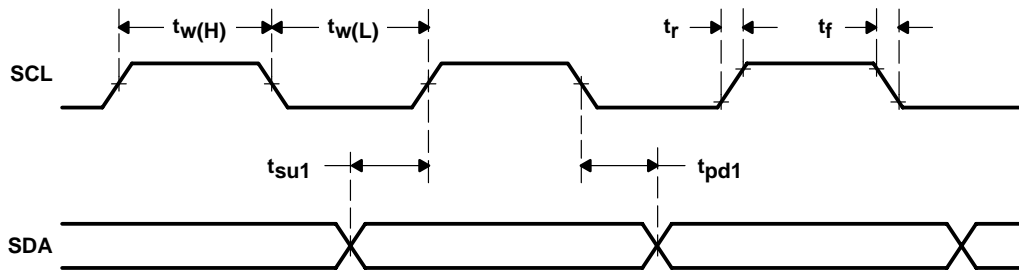

Figure 3–7. SCL and SDA Timing Waveforms

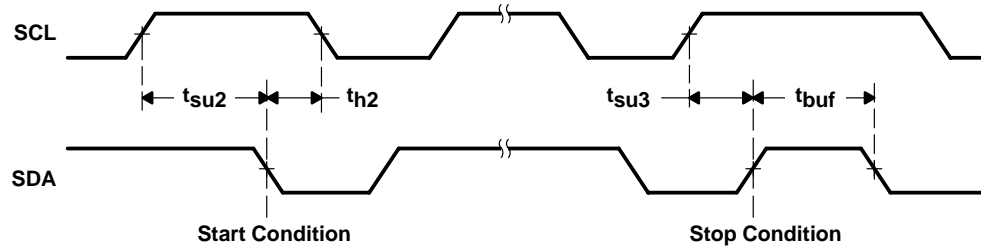

Figure 3–8. Start and Stop Conditions Timing Waveforms

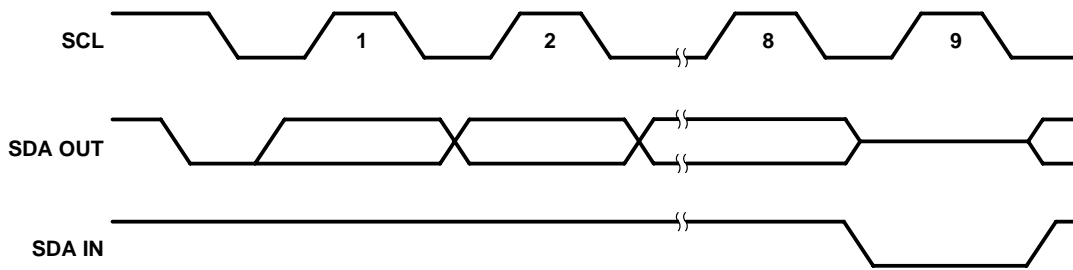
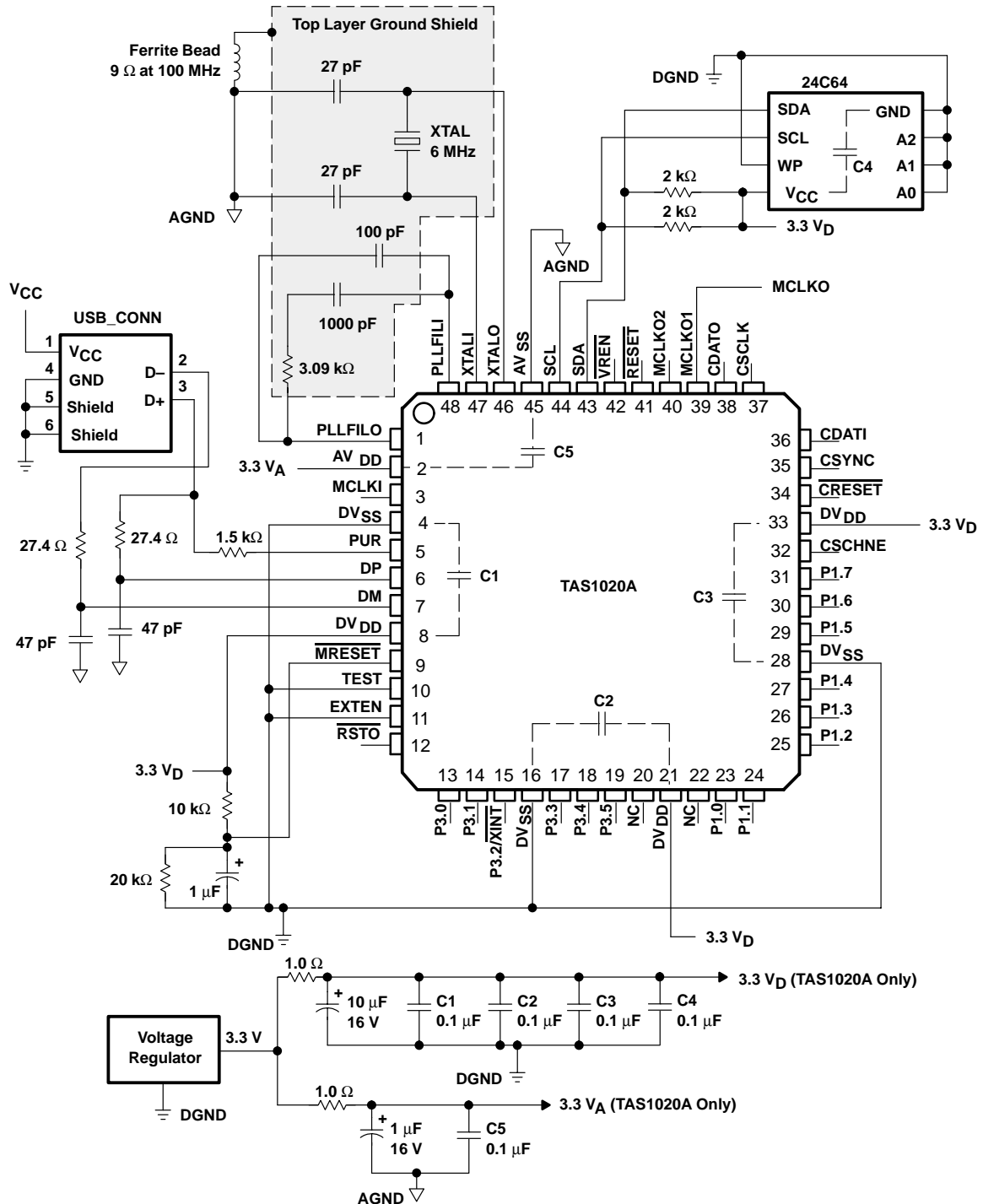

Figure 3–9. Acknowledge Timing Waveform



## 4 Application Information



- NOTES:
- A. If MCLKI and CSCHNE are not used, they must be connected to DGND.
  - B. Capacitors C1, C2, C3, C4, and C5 are as shown to indicate they must be mounted as close to the pins as possible.
  - C. NC on pins 20 and 22 means they must be left unconnected when running in normal mode.
  - D. Crystal load capacitors are shown as 27 pF, but recommendations of crystal manufactures should be followed.

**Figure 4–1. Typical TAS1020A Device Connections**



## **Appendix A**

### **MCU Memory and Memory-Mapped Registers**

This section describes the TAS1020A MCU memory configurations and operation. In general, the MCU memory operation is the same as the industry standard 8052 MCU.

#### **A.1 MCU Memory Space**

The TAS1020A MCU memory is organized into three individual spaces: program memory, external data memory, and internal data memory. All memory resources reside within the TAS1020A; the terms internal and external refer to memory resources internal to and external to the MCU core residing in the TAS1020A. The total address range for the program memory and the external data memory spaces is 64K bytes each. The total address range for the internal data memory is 256 bytes.

The actual mapping of physical memory resources into these three individual spaces is dependent on which operating mode is active, boot loader mode or normal mode. The operating mode is determined by the setting of the SDW bit in the MCU memory configuration register. At power turnon, or after a master reset, the SDW bit is reset and the boot loader mode is active. In this mode, an 8K ROM resource within the TAS1020A is mapped to program space beginning at address 0000h. This same 8K ROM is also mapped to program space beginning at address 8000h. The TAS1020A uses the 8K boot ROM as the program memory when in the boot loader mode. The boot ROM program code downloads the application program code from a nonvolatile memory (EEPROM) on the peripheral PCB, and writes the code to a 6K RAM resource internal to the TAS1020A. In the boot loader mode, this 6K RAM resource is mapped to the external data memory space starting at address 0000h. (If a valid EEPROM resource is not available, the TAS1020A initializes in the DFU program mode and requires a download of application code to RAM—see Section 2.2.2.2). After downloading the application program code to the 6K RAM resource, the boot ROM enables the normal operating mode by setting the ROM disable (SDW) bit to enable program code execution from the 6K RAM instead of the boot ROM. In the normal operating mode, the boot ROM is still mapped to program memory space starting at address 8000h, but the 6K RAM resource is now mapped to program memory space beginning at address 0000h. Also, in the normal operating mode, the RAM resource becomes a read-only memory resource that cannot be written to. Refer to Figures A–1 and A–2 for details.

In the normal operating mode, the external data memory space contains the data buffers for the USB endpoints, the configuration blocks for the USB endpoints, the setup data packet buffer for the USB control endpoint, and memory-mapped registers. The data buffers for the USB endpoints, the configuration blocks for the USB endpoints and the setup data packet buffer for the USB control endpoints are all implemented in RAM, and this RAM resource is separate from the 6K RAM resource used to house the application code. The memory-mapped registers used for control and status registers are implemented in hardware with flip-flops. The data buffers for the USB endpoints total 1304 bytes, the configuration blocks for the USB endpoints total 128 bytes, the setup packet buffer for the USB control endpoint is 8 bytes, and the memory-mapped-register space is 80 bytes. The total external data memory space used for these blocks of memory then is 1520 bytes.

## A.2 Internal Data Memory

The internal data memory space is a total of 256 bytes of RAM, which includes the 128 bytes of special function registers (SFR) space. The internal data memory space is mapped in accordance with the industry standard 8052 MCU. The internal data memory space is mapped from 00h to FFh with the SFRs mapped from 80h to FFh. The lower 128 bytes are accessible with both direct and indirect addressing. However, the upper 128 bytes, which is the SFR space, is only accessible with direct addressing. Note that the internal data memory space is separate and distinct from the external data memory space, and although both spaces begin at address 0000h, there is no overlap.

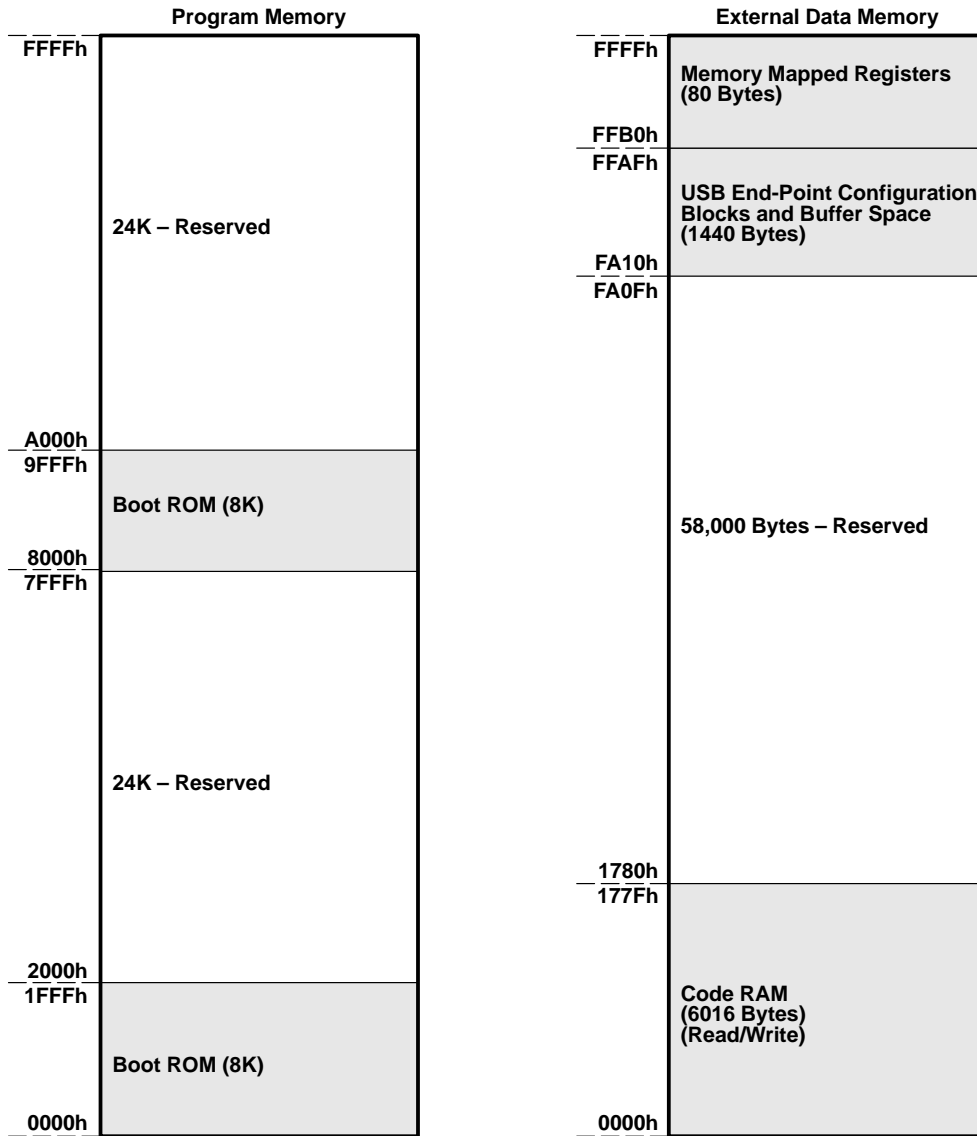

Figure A–1. Boot Loader Mode Memory Map

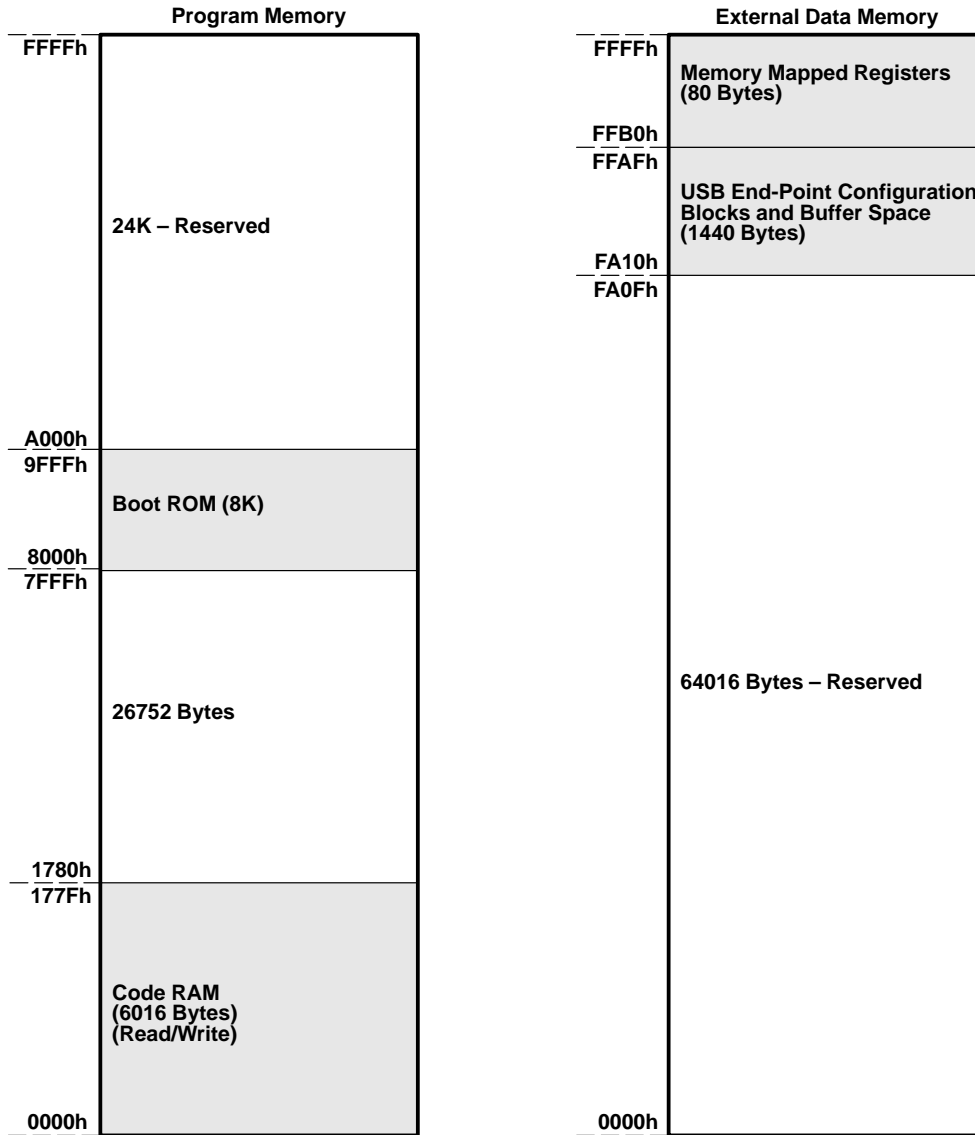

Figure A-2. Normal Operating Mode Memory Map

### A.3 External MCU Mode Memory Space

When using an external MCU for firmware development, only the USB configuration blocks, the USB buffer space, and the memory-mapped registers are accessible by the external MCU. See Section A.4 for details. In this mode, only address lines A0 to A10 are input to the TAS1020A device from the external MCU. Therefore, the USB buffer space and the memory-mapped registers in the external data memory space are not fully decoded since all sixteen address lines are not available. Hence, the USB buffer space and the memory-mapped registers are actually accessible at any 2K boundary within the total 64K external data memory space of the external MCU. As a result, when using the TAS1020A in the external MCU mode, nothing can be mapped to the external data memory space of the external MCU except the USB buffer space and the memory-mapped registers of the TAS1020A device.

## A.4 USB Endpoint Configuration Blocks and Data Buffer Space

### A.4.1 USB Endpoint Configuration Blocks

The USB endpoint configuration space contains 16 8-byte blocks that define configuration, buffer location, buffer size, and data count for the 16 (8 input and 8 output) USB endpoints. The MCU, UBM, and DMA all have access to these configuration blocks.

Each of the 16 endpoints in the TAS1020A can be configured as a USB pipe endpoint by initializing the block configuration register assigned to each endpoint. The location of the endpoint X and Y data buffers for each endpoint is set by the value programmed into the X and Y buffer base address registers. Base addresses are octet (8-byte) aligned. The size of the X and Y buffers is set by initializing the buffer size register. The size of the X and Y buffers must be greater than or equal to the USB packet size associated with the endpoint. For Isochronous endpoints, the buffer size defines the size of the single circular buffer. For IN transactions, the X and Y data count registers assigned to each endpoint are set by the USB buffer manager (UBM) to register the size of the new data packet just received. For OUT transactions, the X and Y data count registers assigned to each endpoint are set by the DMA logic or the MCU to register the size of the data packet to be output. For control, interrupt, and bulk transactions, the data count is the number of samples per transaction.

### A.4.2 Data Buffer Space

The endpoint data buffer space (1304 bytes) provides rate buffering between the data traffic on the USB bus and data traffic to and from the codecs attached to the TAS1020A. Buffers are defined in this space by base address pointers and size descriptors in the USB endpoint configuration blocks. The MCU also has access to this space.

In order to conserve RAM memory resources on the TAS1020A, several USB-specific routines have been included in the firmware resident in the on-chip ROM. These ROM support functions are detailed in Section 2.2.2.7. To provide temporary variable storage for these ROM support functions, locations FA10h through FA63h (84 bytes) of the 1304 bytes of data buffer space are reserved for use by the ROM support functions. This then leaves 1220 bytes for the endpoint buffer memories, which service applications up to 6 channels, 48 kHz sampling rate with 16 bits per sample or 4 channels, 48-kHz sampling rate with 24 bits per sample. (If the ROM support functions are not used, the entire block of 1304 bytes can be assigned to endpoint buffer memories.)

The values entered into the X and Y buffer base address registers are offset addresses. The lower memory address (or Base address) of a given X (Y) buffer is determined by adding the value in the base address register (multiplied by 8) to the base address of the block of memory assigned to the X and Y buffers. For the TAS1020A, this base address is FA10h. However, the base address of the TUSB3200 members of the family of USB streaming audio controllers, of which the TAS1020A is also a member, is F800h. To maintain software compatibility between family members, the value entered into the base address register for the TAS1020A (as well as the other family members) must be the offset from the base address F800h. For example, assume the X buffer for IN endpoint 3 is to be established starting at address FA60h. For the TAS1020A, the offset of this address from the FA10h base address of the block of memory assigned to the X and Y buffers is 50h. Nevertheless, the value entered into the X buffer base address for IN endpoint 3 must be 4Ch, as  $F800h + 8 * 4Ch = FA60h$ .



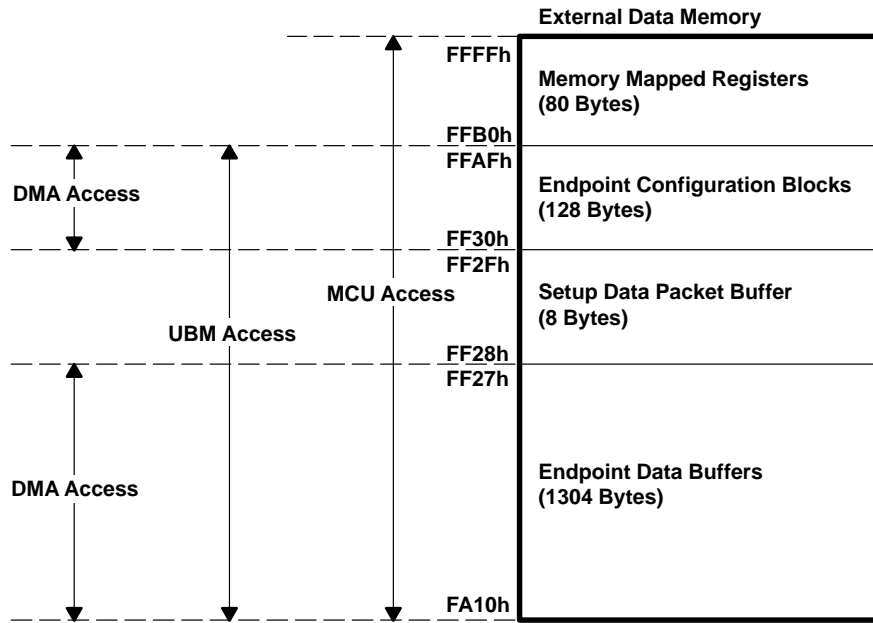

Figure A-3. USB Endpoint Configuration Blocks and Buffer Space Memory Map

**Table A-1. USB Endpoint Configuration Blocks Address Map**

ADDRESS	MNEMONIC	NAME
FFAFh	OEPDCNTY0	OUT endpoint 0 - Y buffer data count byte
FFAEh	Reserved	Reserved for future use
FFADh	OEPBBAY0	OUT endpoint 0 - Y buffer base address byte
FFACh	Reserved	Reserved for future use
FFABh	OEPDCNTX0	OUT endpoint 0 - X buffer data count byte
FFAAh	OEPBSIZ0	OUT endpoint 0 - X and Y buffer size byte
FFA9h	OEPBBAX0	OUT endpoint 0 - X buffer base address byte
FFA8h	OEP CNF0	OUT endpoint 0 – configuration byte
FFA7h	OEPDCNTY1	OUT endpoint 1 - Y buffer data count byte
FFA6h	Reserved	Reserved for future use
FFA5h	OEPBBAY1	OUT endpoint 1 - Y buffer base address byte
FFA4h	Reserved	Reserved for future use
FFA3h	OEPDCNTX1	OUT endpoint 1 - X buffer data count byte
FFA2h	OEPBSIZ1	OUT endpoint 1 - X and Y buffer size byte
FFA1h	OEPBBAX1	OUT endpoint 1 - X buffer base address byte
FFA0h	OEP CNF1	OUT endpoint 1 – configuration byte
FF9Fh	OEPDCNTY2	OUT endpoint 2 - Y buffer data count byte
FF9Eh	Reserved	Reserved for future use
FF9Dh	OEPBBAY2	OUT endpoint 2 - Y buffer base address byte
FF9Ch	Reserved	Reserved for future use
FF9Bh	OEPDCNTX2	OUT endpoint 2 - X buffer data count byte
FF9Ah	OEPBSIZ2	OUT endpoint 2 - X and Y buffer size byte
FF99h	OEPBBAX2	OUT endpoint 2 - X buffer base address byte
FF98h	OEP CNF2	OUT endpoint 2 – configuration byte
FF97h	OEPDCNTY3	OUT endpoint 3 - Y buffer data count byte
FF96h	Reserved	Reserved for future use
FF95h	OEPBBAY3	OUT endpoint 3 - Y buffer base address byte
FF94h	Reserved	Reserved for future use
FF93h	OEPDCNTX3	OUT endpoint 3 - X buffer data count byte
FF92h	OEPBSIZ3	OUT endpoint 3 - X and Y buffer size byte
FF91h	OEPBBAX3	OUT endpoint 3 - X buffer base address byte
FF90h	OEP CNF3	OUT endpoint 3 – configuration byte
FF8Fh	OEPDCNTY4	OUT endpoint 4 - Y buffer data count byte
FF8Eh	Reserved	Reserved for future use
FF8Dh	OEPBBAY4	OUT endpoint 4 - Y buffer base address byte
FF8Ch	Reserved	Reserved for future use
FF8Bh	OEPDCNTX4	OUT endpoint 4 - X buffer data count byte
FF8Ah	OEPBSIZ4	OUT endpoint 4 - X and Y buffer size byte
FF89h	OEPBBAX4	OUT endpoint 4 - X buffer base address byte
FF88h	OEP CNF4	OUT endpoint 4 – configuration byte
FF87h	OEPDCNTY5	OUT endpoint 5 - Y buffer data count byte
FF86h	Reserved	Reserved for future use
FF85h	OEPBBAY5	OUT endpoint 5 - Y buffer base address byte
FF84h	Reserved	Reserved for future use
FF83h	OEPDCNTX5	OUT endpoint 5 - X buffer data count byte
FF82h	OEPBSIZ5	OUT endpoint 5 - X and Y buffer size byte
FF81h	OEPBBAX5	OUT endpoint 5 - X Buffer Base Address Byte
FF80h	OEP CNF5	OUT endpoint 5 – configuration byte

**Table A-1. USB Endpoint Configuration Blocks Address Map (Continued)**

ADDRESS	MNEMONIC	NAME
FF7Fh	OEPDCNTY6	OUT endpoint 6 - Y buffer data count byte
FF7Eh	Reserved	Reserved for future use
FF7Dh	OEPBBAY6	OUT endpoint 6 - Y buffer base address byte
FF7Ch	Reserved	Reserved for future use
FF7Bh	OEPDCNTX6	OUT endpoint 6 - X buffer data count byte
FF7Ah	OEPBSIZ6	OUT endpoint 6 - X and Y buffer size byte
FF79h	OEPBBAX6	OUT endpoint 6 - X buffer base address byte
FF78h	OEP CNF6	OUT endpoint 6 – configuration byte
FF77h	OEPDCNTY7	OUT endpoint 7 - Y buffer data count byte
FF76h	Reserved	Reserved for future use
FF75h	OEPBBAY7	OUT endpoint 7 - Y buffer base address byte
FF74h	Reserved	Reserved for future use
FF73h	OEPDCNTX7	OUT endpoint 7 - X buffer data count byte
FF72h	OEPBSIZ7	OUT endpoint 7 - X and Y buffer size byte
FF71h	OEPBBAX7	OUT endpoint 7 - X buffer base address byte
FF70h	OEP CNF7	OUT endpoint 7 – configuration byte
FF6Fh	IEPDCNTY0	IN endpoint 0 - Y buffer data count byte
FF6Eh	Reserved	Reserved for future use
FF6Dh	IEPBBAY0	IN endpoint 0 - Y buffer base address byte
FF6Ch	Reserved	Reserved for future use
FF6Bh	IEPDCNTX0	IN endpoint 0 - X buffer data count byte
FF6Ah	IEPBSIZ0	IN endpoint 0 - X and Y buffer size byte
FF69h	IEPBBAX0	IN endpoint 0 - X buffer base address byte
FF68h	IEP CNF0	IN endpoint 0 – configuration byte
FF67h	IEPDCNTY1	IN endpoint 1 - Y buffer data count byte
FF66h	Reserved	Reserved for future use
FF65h	IEPBBAY1	IN endpoint 1 - Y buffer base address byte
FF64h	Reserved	Reserved for future use
FF63h	IEPDCNTX1	IN endpoint 1 - X buffer data count byte
FF62h	IEPBSIZ1	IN endpoint 1 - X and Y buffer size byte
FF61h	IEPBBAX1	IN endpoint 1 - X buffer base address byte
FF60h	IEP CNF1	IN endpoint 1 – configuration byte
FF5Fh	IEPDCNTY2	IN endpoint 2 - Y buffer data count byte
FF5Eh	Reserved	Reserved for future use
FF5Dh	IEPBBAY2	IN endpoint 2 - Y buffer base address byte
FF5Ch	Reserved	Reserved for future use
FF5Bh	IEPDCNTX2	IN endpoint 2 - X buffer data count byte
FF5Ah	IEPBSIZ2	IN endpoint 2 - X and Y buffer size byte
FF59h	IEPBBAX2	IN endpoint 2 - X buffer base address byte
FF58h	IEP CNF2	IN endpoint 2 – configuration byte
FF57h	IEPDCNTY3	IN endpoint 3 - Y buffer data count byte
FF56h	Reserved	Reserved for future use
FF55h	IEPBBAY3	IN endpoint 3 - Y buffer base address byte
FF54h	Reserved	Reserved for future use
FF53h	IEPDCNTX3	IN endpoint 3 - X buffer data count byte
FF52h	IEPBSIZ3	IN endpoint 3 - X and Y buffer size byte
FF51h	IEPBBAX3	IN endpoint 3 - X buffer base address byte
FF50h	IEP CNF3	IN endpoint 3 – configuration byte

**Table A-1. USB Endpoint Configuration Blocks Address Map (Continued)**

ADDRESS	MNEMONIC	NAME
FF4Fh	IEPDCNTY4	IN endpoint 4 - Y buffer data count byte
FF4Eh	Reserved	Reserved for future use
FF4Dh	IEPBAY4	IN endpoint 4 - Y buffer base address byte
FF4Ch	Reserved	Reserved for future use
FF4Bh	IEPDCNTX4	IN endpoint 4 - X buffer data count byte
FF4Ah	IEPBSIZ4	IN endpoint 4 - X and Y buffer size byte
FF49h	IEPBAX4	IN endpoint 4 - X buffer base address byte
FF48h	IEPCNF4	IN endpoint 4 – configuration byte
FF47h	IEPDCNTY5	IN endpoint 5 - Y buffer data count byte
FF46h	Reserved	Reserved for future use
FF45h	IEPBAY5	IN endpoint 5 - Y buffer base address byte
FF44h	Reserved	Reserved for future use
FF43h	IEPDCNTX5	IN endpoint 5 - X buffer data count byte
FF42h	IEPBSIZ5	IN endpoint 5 - X and Y buffer size byte
FF41h	IEPBAX5	IN endpoint 5 - X buffer base address byte
FF40h	IEPCNF5	IN endpoint 5 – configuration byte
FF3Fh	IEPDCNTY6	IN endpoint 6 - Y buffer data count byte
FF3Eh	Reserved	Reserved for future use
FF3Dh	IEPBAY6	IN endpoint 6 - Y buffer base address byte
FF3Ch	Reserved	Reserved for future use
FF3Bh	IEPDCNTX6	IN endpoint 6 - X buffer data count byte
FF3Ah	IEPBSIZ6	IN endpoint 6 - X and Y buffer size byte
FF39h	IEPBAX6	IN endpoint 6 - X buffer base address byte
FF38h	IEPCNF6	IN endpoint 6 – configuration byte
FF37h	IEPDCNTY7	IN endpoint 7 - Y buffer data count byte
FF36h	Reserved	Reserved for future use
FF35h	IEPBAY7	IN endpoint 7 - Y buffer base address byte
FF34h	Reserved	Reserved for future use
FF33h	IEPDCNTX7	IN endpoint 7 - X buffer data count byte
FF32h	IEPBSIZ7	IN endpoint 7 - X and Y buffer size byte
FF31h	IEPBAX7	IN endpoint 7 - X buffer base address byte
FF30h	IEPCNF7	IN endpoint 7 – configuration byte

### A.4.3 USB OUT Endpoint Configuration Bytes

This section describes the individual bytes in the USB endpoint configuration blocks for the OUT endpoints. A set of 8 bytes is used for the control and operation of each USB OUT endpoint. In addition to the USB control endpoint, the TAS1020A supports up to a total of seven OUT endpoints.

#### A.4.3.1 USB OUT Endpoint – Y Buffer Data Count Byte (OEPDCNTYx)

The USB OUT endpoint Y buffer data count byte contains the 7-bit value used to specify the amount of data received in a data packet from the host PC. The no acknowledge status bit is also contained in this byte.

Bit	7	6	5	4	3	2	1	0
Mnemonic	NACK	DCNTY6	DCNTY5	DCNTY4	DCNTY3	DCNTY2	DCNTY1	DCNTY0
Type	R/W	R/W	R/W	R/W	R/W	R/W	R/W	R/W

BIT	MNEMONIC	NAME	DESCRIPTION
7	NACK	No acknowledge	The no acknowledge status bit is set to a 1 by the UBM at the end of a successful USB OUT transaction to this endpoint to indicate that the USB endpoint Y buffer contains a valid data packet and that the Y buffer data count value is valid. For control, interrupt, or bulk endpoints, when this bit is set to a 1, all subsequent transactions to the endpoint result in a NACK handshake response to the host PC. Also for control, interrupt, and bulk endpoints to enable this endpoint to receive another data packet from the host PC, this bit must be cleared to a 0 by the MCU. For isochronous endpoints, a NACK handshake response to the host PC is not allowed. Therefore, the UBM ignores this bit in reference to receiving the next data packet. However, the MCU or DMA must clear this bit before reading the data packet from the buffer.
6:0	DCNTY(6:0)	Y Buffer data count	The Y buffer data count value is set by the UBM when a new data packet is written to the Y buffer for the OUT endpoint. The 7-bit value is set to the number of bytes in the data packet for control, interrupt or bulk endpoint transfers and is set to the number of samples in the data packet for isochronous endpoint transfers. To determine the number of samples in the data packet for isochronous transfers, the bytes per sample value in the configuration byte is used. The data count value is read by the MCU or DMA to obtain the data packet size.

#### A.4.3.2 USB OUT Endpoint – Y Buffer Base Address Byte (OEPBBAYx)

The USB OUT endpoint Y buffer base address byte contains the 8-bit value used to specify the base memory location for the Y data buffer for a particular USB OUT endpoint.

Bit	7	6	5	4	3	2	1	0
Mnemonic	BBAY10	BBAY9	BBAY8	BBAY7	BBAY6	BBAY5	BBAY4	BBAY3
Type	R/W	R/W	R/W	R/W	R/W	R/W	R/W	R/W

BIT	MNEMONIC	NAME	DESCRIPTION
7:0	BBAY(10:3)	Y Buffer base address	The Y buffer base address value is set by the MCU to program the base address location in memory to be used for the Y data buffer. A total of 11 bits is used to specify the base address location. This byte specifies the most significant 8 bits of the address. All 0s are used by the hardware for the three least significant bits.

### A.4.3.3 USB OUT Endpoint – X Buffer Data Count Byte (OEPDCNTXx)

The USB OUT endpoint X buffer data count byte contains the 7-bit value used to specify the amount of data received in a data packet from the host PC. The no acknowledge status bit is also contained in this byte.

Bit	7	6	5	4	3	2	1	0
Mnemonic	NACK	DCNTX6	DCNTX5	DCNTX4	DCNTX3	DCNTX2	DCNTX1	DCNTX0
Type	R/W	R/W	R/W	R/W	R/W	R/W	R/W	R/W

BIT	MNEMONIC	NAME	DESCRIPTION
7	NACK	No acknowledge	The no acknowledge status bit is set to a 1 by the UBM at the end of a successful USB OUT transaction to this endpoint to indicate that the USB endpoint X buffer contains a valid data packet and that the X buffer data count value is valid. For control, interrupt, or bulk endpoints, when this bit is set to a 1, all subsequent transactions to the endpoint result in a NACK handshake response to the host PC. Also for control, interrupt, and bulk endpoints to enable this endpoint to receive another data packet from the host PC, this bit must be cleared to a 0 by the MCU. For isochronous endpoints, a NACK handshake response to the host PC is not allowed. Therefore, the UBM ignores this bit in reference to receiving the next data packet. However, the MCU or DMA must clear this bit before reading the data packet from the buffer.
6:0	DCNTX(6:0)	X Buffer data count	The X buffer data count value is set by the UBM when a new data packet is written to the X buffer for the OUT endpoint. The 7-bit value is set to the number of bytes in the data packet for control, interrupt, or bulk endpoint transfers and is set to the number of samples in the data packet for isochronous endpoint transfers. To determine the number of samples in the data packet for isochronous transfers, the bytes per sample value in the configuration byte is used. The data count value is read by the MCU or DMA to obtain the data packet size.

### A.4.3.4 USB OUT Endpoint – X and Y Buffer Size Byte (OEPBSIZx)

The USB OUT endpoint X and Y buffer size byte contains the 8-bit value used to specify the size of the two data buffers to be used for this endpoint.

Bit	7	6	5	4	3	2	1	0
Mnemonic	BSIZ7	BSIZ6	BSIZ5	BSIZ4	BSIZ3	BSIZ2	BSIZ1	BSIZ0
Type	R/W	R/W	R/W	R/W	R/W	R/W	R/W	R/W

BIT	MNEMONIC	NAME	DESCRIPTION
7:0	BSIZ(7:0)	Buffer size	For control, interrupt, and bulk transactions, the X and Y buffer size value is set by the MCU to program the size of the X and Y data packet buffers. Both buffers are programmed to the same size based on this value. This value is in 8-byte units. For example, a value of 18h results in the size of the X and Y buffers each being set to 192 bytes. For isochronous transactions, the buffer size sets the size of the single circular buffer.

### A.4.3.5 USB OUT Endpoint – X Buffer Base Address Byte (OEPBBAXx)

The USB OUT endpoint X buffer base address byte contains the 8-bit value used to specify the base memory location for the X data buffer for a particular USB OUT endpoint.

Bit	7	6	5	4	3	2	1	0
Mnemonic	BBAX10	BBAX9	BBAX8	BBAX7	BBAX6	BBAX5	BBAX4	BBAX3
Type	R/W	R/W	R/W	R/W	R/W	R/W	R/W	R/W

BIT	MNEMONIC	NAME	DESCRIPTION
7:0	BBAX(10:3)	X Buffer base address	The X buffer base address value is set by the MCU to program the base address location in memory to be used for the X data buffer. A total of 11 bits is used to specify the base address location. This byte specifies the most significant 8 bits of the address. All 0s are used by the hardware for the three least significant bits.

### A.4.3.6 USB OUT Endpoint – Configuration Byte (OEPCNFx)

The USB OUT endpoint configuration byte contains the various bits used to configure and control the endpoint. Note that the bits in this byte take on different functionality based on the type of endpoint defined. The control, interrupt, and bulk endpoints function differently than the isochronous endpoints.

#### A.4.3.6.1 USB OUT Endpoint Configuration Byte Settings—Control, interrupt, or Bulk Transactions

This section defines the functionality of the bits in the USB OUT endpoint configuration byte for control, interrupt, and bulk endpoints.

Bit	7	6	5	4	3	2	1	0
Mnemonic	OEPEN	ISO	TOGGLE	DBUF	STALL	OEPIE	—	—
Type	R/W	R/W	R/W	R/W	R/W	R/W	R/W	R/W

BIT	MNEMONIC	NAME	DESCRIPTION
7	OEPEN	Endpoint enable	The endpoint enable bit is set to 1 by the MCU to enable the OUT endpoint.
6	ISO	Isochronous endpoint	The isochronous endpoint bit is set to a 1 by the MCU to specify the use of a particular OUT endpoint for isochronous transactions. This bit must be cleared to a 0 by the MCU to use a particular OUT endpoint for control, interrupt, or bulk transactions.
5	TOGGLE	Toggle	The toggle bit is controlled by the UBM and is toggled at the end of a successful out data stage transaction if a valid data packet is received and the data packet PID matches the expected PID.
4	DBUF	Double buffer mode	The double buffer mode bit is set to 1 by the MCU to enable the use of both the X and Y data packet buffers for USB transactions to a particular OUT endpoint. This bit must be cleared to a 0 by the MCU to use the single buffer mode. In the single buffer mode, only the X buffer is used.
3	STALL	Stall	The stall bit is set to 1 by the MCU to stall endpoint transactions. When this bit is set, the hardware automatically returns a stall handshake to the host PC for any transaction received for the endpoint. An exception is the control endpoint setup stage transaction, which must always be received. This requirement allows a Clear_Feature_Stall request to be received from the host PC. Control endpoint data and status stage transactions however can be stalled. The stall bit is cleared to a 0 by the MCU if a Clear_Feature_Stall request or a USB reset is received from the host PC. For a control write transaction, if the amount of data received is greater than expected, the UBM sets the stall bit to a 1 to stall the endpoint. When the stall bit is set to a 1 by the UBM, the USB OUT endpoint 0 interrupt is generated.
2	OEPIE	Interrupt enable	The interrupt enable bit is set to a 1 by the MCU to enable the OUT endpoint interrupt. See Section A.5.7.1 for details on the OUT endpoint interrupts.
1:0	—	Reserved	Reserved for future use

### A.4.3.6.2 USB OUT Endpoint Configuration Byte Settings—Isochronous Transactions

This section defines the functionality of the bits in the USB OUT endpoint configuration byte for isochronous endpoints.

Bit	7	6	5	4	3	2	1	0
Mnemonic	OEPEN	ISO	OVF	BPS4	BPS3	BPS2	BPS1	BPS0
Type	R/W	R/W	R/W	R/W	R/W	R/W	R/W	R/W

BIT	MNEMONIC	NAME	DESCRIPTION
7	OEPEN	Endpoint enable	The endpoint enable bit is set to a 1 by the MCU to enable the OUT endpoint.
6	ISO	Isochronous endpoint	The isochronous endpoint bit is set to a 1 by the MCU to specify the use of a particular OUT endpoint for isochronous transactions. This bit must be cleared to a 0 by the MCU for a particular OUT endpoint to be used for control, interrupt, or bulk transactions.
5	OVF	Overflow	The overflow bit is set to a 1 by the UBM to indicate a buffer overflow condition has occurred. This bit is used for diagnostic purposes only and is not used for normal operation. This bit can only be cleared to a 0 by the MCU.
4:0	BPS(4:0)	Bytes per sample	The bytes per sample bits are used to define the number of bytes per isochronous data sample. In other words, the total number of bytes in an entire audio codec frame. For example, a PCM 16-bit stereo audio data sample consists of 4 bytes. There are two bytes of left channel data and two bytes of right channel data. For a four channel system using 16-bit data, the total number of bytes is 8, which is the isochronous data sample size. 00h = 1 byte, 01h = 2 bytes, ..., 1Fh = 32 bytes

### A.4.4 USB IN Endpoint Configuration Bytes

This section describes the individual bytes in the USB endpoint configuration blocks for the IN endpoints. A set of 8 bytes is used for the control and operation of each USB IN endpoint. In addition to the USB control endpoint, the TAS1020A supports up to a total of seven IN endpoints.

#### A.4.4.1 USB IN Endpoint – Y Buffer Data Count Byte (IEPDCNTYx)

The USB IN endpoint Y buffer data count byte contains the 7-bit value used to specify the amount of data to be transmitted in a data packet to the host PC. The no acknowledge status bit is also contained in this byte.

Bit	7	6	5	4	3	2	1	0
Mnemonic	NACK	DCNTY6	DCNTY5	DCNTY4	DCNTY3	DCNTY2	DCNTY1	DCNTY0
Type	R/W	R/W	R/W	R/W	R/W	R/W	R/W	R/W

BIT	MNEMONIC	NAME	DESCRIPTION
7	NACK	No acknowledge	The no acknowledge status bit is set to a 1 by the UBM at the end of a successful USB IN transaction to this endpoint to indicate that the USB endpoint Y buffer is empty. For control, interrupt, or bulk endpoints, when this bit is set to a 1, all subsequent transactions to the endpoint result in a NACK handshake response to the host PC. Also for control, interrupt, and bulk endpoints to enable this endpoint to transmit another data packet to the Host PC, this bit must be cleared to a 0 by the MCU. For isochronous endpoints, a NACK handshake response to the host PC is not allowed. Therefore, the UBM ignores this bit in reference to sending the next data packet. However, the MCU or DMA must clear this bit after writing a data packet to the buffer.
6:0	DCNTY(6:0)	Y Buffer data count	The Y buffer data count value is set by the MCU or DMA when a new data packet is written to the Y buffer for the IN endpoint. The 7-bit value is set to the number of bytes in the data packet for control, interrupt, or bulk endpoint transfers and is set to the number of samples in the data packet for isochronous endpoint transfers. To determine the number of samples in the data packet for isochronous transfers, the bytes per sample value in the configuration byte is used.



#### A.4.4.2 USB IN Endpoint – Y Buffer Base Address Byte (IEPBAYx)

The USB IN endpoint Y buffer base address byte contains the 8-bit value used to specify the base memory location for the Y data buffer for a particular USB IN endpoint.

Bit	7	6	5	4	3	2	1	0
Mnemonic	BBAY10	BBAY9	BBAY8	BBAY7	BBAY6	BBAY5	BBAY4	BBAY3
Type	R/W	R/W	R/W	R/W	R/W	R/W	R/W	R/W

BIT	MNEMONIC	NAME	DESCRIPTION
7:0	BBAY(10:3)	Y Buffer base address	The Y buffer base address value is set by the MCU to program the base address location in memory to be used for the Y data buffer. A total of 11 bits is used to specify the base address location. This byte specifies the most significant 8 bits of the address. All 0s are used by the hardware for the three least significant bits.

#### A.4.4.3 USB IN Endpoint – X Buffer Data Count Byte (IEPDCNTXx)

The USB IN endpoint X buffer data count byte contains the 7-bit value used to specify the amount of data received in a data packet from the host PC. The no acknowledge status bit is also contained in this byte.

Bit	7	6	5	4	3	2	1	0
Mnemonic	NACK	DCNTX6	DCNTX5	DCNTX4	DCNTX3	DCNTX2	DCNTX1	DCNTX0
Type	R/W	R/W	R/W	R/W	R/W	R/W	R/W	R/W

BIT	MNEMONIC	NAME	DESCRIPTION
7	NACK	No acknowledge	The no acknowledge status bit is set to a 1 by the UBM at the end of a successful USB IN transaction to this endpoint to indicate that the USB endpoint X buffer is empty. For control, interrupt, or bulk endpoints, when this bit is set to a 1, all subsequent transactions to the endpoint result in a NACK handshake response to the host PC. Also for control, interrupt, and bulk endpoints to enable this endpoint to transmit another data packet to the host PC, this bit must be cleared to a 0 by the MCU. For isochronous endpoints, a NACK handshake response to the host PC is not allowed. Therefore, the UBM ignores this bit in reference to sending the next data packet. However, the MCU or DMA must clear this bit after writing a data packet to the buffer.
6:0	DCNTX(6:0)	X Buffer data count	The X buffer data count value is set by the MCU or DMA when a new data packet is written to the X buffer for the IN endpoint. The 7-bit value is set to the number of bytes in the data packet for control, interrupt, or bulk endpoint transfers and is set to the number of samples in the data packet for isochronous endpoint transfers. To determine the number of samples in the data packet for isochronous transfers, the bytes per sample value in the configuration byte is used.

#### A.4.4.4 USB IN Endpoint – X and Y Buffer Size Byte (IEPBSIZx)

The USB IN endpoint X and Y buffer size byte contains the 8-bit value used to specify the size of the two data buffers to be used for this endpoint.

Bit	7	6	5	4	3	2	1	0
Mnemonic	BSIZ7	BSIZ6	BSIZ5	BSIZ4	BSIZ3	BSIZ2	BSIZ1	BSIZ0
Type	R/W	R/W	R/W	R/W	R/W	R/W	R/W	R/W

BIT	MNEMONIC	NAME	DESCRIPTION
7	BSIZ(7:0)	Buffer size	For control, interrupt, and bulk transactions, the X and Y buffer size value is set by the MCU to program the size of the X and Y data packet buffers. Both buffers are programmed to the same size based on this value. This value should be in 8 byte units. For example, a value of 18h results in the size of the X and Y buffers each being set to 192 bytes. For isochronous transactions, the buffer size sets the size of the single circular buffer.

#### A.4.4.5 USB IN Endpoint – X Buffer Base Address Byte (IEPBBAx)

The USB IN endpoint X buffer base address byte contains the 8-bit value used to specify the base memory location for the X data buffer for a particular USB IN endpoint.

Bit	7	6	5	4	3	2	1	0
Mnemonic	BBAX10	BBAX9	BBAX8	BBAX7	BBAX6	BBAX5	BBAX4	BBAX3
Type	R/W	R/W	R/W	R/W	R/W	R/W	R/W	R/W

BIT	MNEMONIC	NAME	DESCRIPTION
7:0	BBAX(10:3)	X Buffer base address	The X buffer base address value is set by the MCU to program the base address location in memory to be used for the X data buffer. A total of 11 bits is used to specify the base address location. This byte specifies the most significant 8 bits of the address. All 0s are used by the hardware for the three least significant bits.

#### A.4.4.6 USB IN Endpoint – Configuration Byte (IEPCNFx)

The USB IN endpoint configuration byte contains the various bits used to configure and control the endpoint. Note that the bits in this byte take on different functionality based on the type of endpoint defined. Basically, the control, interrupt and bulk endpoints function differently than the isochronous endpoints.

##### A.4.4.6.1 USB IN Endpoint Configuration Byte Settings – Control, Interrupt or Bulk Transactions

This section defines the functionality of the bits in the USB IN endpoint configuration byte for control, interrupt, and bulk endpoints.

Bit	7	6	5	4	3	2	1	0
Mnemonic	IEPEN	ISO	TOGGLE	DBUF	STALL	IEPIE	—	—
Type	R/W	R/W	R/W	R/W	R/W	R/W	R/W	R/W

BIT	MNEMONIC	NAME	DESCRIPTION
7	IEPEN	Endpoint enable	The endpoint enable bit is set to a 1 by the MCU to enable the IN endpoint. This bit does not affect the reception of the control endpoint setup stage transaction.
6	ISO	Isochronous endpoint	The isochronous endpoint bit is set to a 1 by the MCU to specify the use of a particular IN endpoint for isochronous transactions. This bit must be cleared to a 0 by the MCU to use a particular IN endpoint for control, interrupt, or bulk transactions.
5	TOGGLE	Toggle	The toggle bit is controlled by the UBM and is toggled at the end of a successful in data stage transaction if a valid data packet is transmitted. If this bit is a 0, a DATA0 PID is transmitted in the data packet to the host PC. If this bit is a 1, a DATA1 PID is transmitted in the data packet.
4	DBUF	Double buffer mode	The double buffer mode bit is set to a 1 by the MCU to enable the use of both the X and Y data packet buffers for USB transactions to a particular IN endpoint. This bit must be cleared to a 0 by the MCU to use the single buffer mode. In the single buffer mode, only the X buffer is used.
3	STALL	Stall	The stall bit is set to a 1 by the MCU to stall endpoint transactions. When this bit is set, the hardware automatically returns a stall handshake to the host PC for any transaction received for the endpoint.
2	IEPIE	Interrupt enable	The interrupt enable bit is set to a 1 by the MCU to enable the IN endpoint interrupt. See Section A.5.7.2 for details on the IN endpoint interrupts.
1:0	—	Reserved	Reserved for future use.

#### A.4.4.6.2 USB IN Endpoint Configuration Byte Settings – Isochronous Transactions

This section defines the functionality of the bits in the USB IN endpoint configuration byte for isochronous endpoints.

Bit	7	6	5	4	3	2	1	0
Mnemonic	IEPEN	ISO	OVF	BPS4	BPS3	BPS2	BPS1	BPS0
Type	R/W	R/W	R/W	R/W	R/W	R/W	R/W	R/W

BIT	MNEMONIC	NAME	DESCRIPTION
7	IEPEN	Endpoint enable	The endpoint enable bit is set to a 1 by the MCU to enable the IN endpoint.
6	ISO	Isochronous endpoint	The isochronous endpoint bit is set to a 1 by the MCU to specify the use of a particular IN endpoint for isochronous transactions. This bit must be cleared to a 0 by the MCU for a particular IN endpoint to be used for control, interrupt, or bulk transactions.
5	OVF	Overflow	The overflow bit is set to a 1 by the UBM to indicate a buffer overflow condition has occurred. This bit is used for diagnostic purposes only and is not used for normal operation. This bit can only be cleared to a 0 by the MCU.
4:0	BPS(4:0)	Bytes per sample	The bytes per sample bits are used to define the number of bytes per isochronous data sample. In other words, the total number of bytes in an entire audio codec frame. For example, a PCM 16-bit stereo audio data sample consists of 4 bytes. There are two bytes of left channel data and two bytes of right channel data. For a four channel system using 16-bit data, the total number of bytes is 8, which is the isochronous data sample size. 00h = 1 byte, 01h = 2 bytes, ..., 1Fh = 32 bytes

#### A.4.5 USB Control Endpoint Setup Stage Data Packet Buffer

The USB control endpoint setup stage data packet buffer is the buffer space used to store the 8-byte data packet received from the host PC during a control endpoint transfer setup stage transaction. Refer to Chapter 9 of the USB Specification for details on the data packet.

**Table A–2. USB Control Endpoint Setup Data Packet Buffer Address Map**

ADDRESS	NAME
FF2Fh	wLength – Number of bytes to transfer in the data stage
FF2Eh	wLength – Number of bytes to transfer in the data stage
FF2Dh	wIndex – Index or offset value
FF2Ch	wIndex – Index or offset value
FF2Bh	wValue – Value of a parameter specific to the request
FF2Ah	wValue – Value of a parameter specific to the request
FF29h	bRequest – Specifies the particular request
FF28h	bmRequestType – Identifies the characteristics of the request

## A.5 Memory-Mapped Registers

The TAS1020A device provides a set of control and status registers to be used by the MCU to control the overall operation of the device. This section describes the memory-mapped registers.

**Table A-3. Memory-Mapped Registers Address Map**

ADDRESS	MNEMONIC	NAME	SECTION	PAGE
FFFFh	USBFADR	USB function address register	A.5.1.1	A-17
FFFEh	USBSTA	USB status register	A.5.1.2	A-18
FFFDh	USBIMSK	USB interrupt mask register	A.5.1.3	A-19
FFFCh	USBCTL	USB control register	A.5.1.4	A-19
FFFBh	USBFNL	USB frame number register (low-byte)	A.5.1.5	A-20
FFFAh	USBFNH	USB frame number register (high-byte)	A.5.1.6	A-20
FFF9h	ACG2FRQ0	Adaptive clock generator2 frequency register (Byte 0)	A.5.3.6	A-25
FFF8h	ACG2FRQ1	Adaptive clock generator2 frequency register (Byte 1)	A.5.3.7	A-25
FFF7h	ACG2FRQ2	Adaptive clock generator2 frequency register (Byte 2)	A.5.3.8	A-26
FFF6h	ACG2DCTL	Adaptive clock generator2 divider control register	A.5.3.9	A-26
FFF5h	Reserved	Reserved for future use		
FFF4h	DMABCNT1H	DMA buffer content register (high-byte) (channel 1)	A.5.2.5	A-22
FFF3h	DMABCNT1L	DMA buffer content register (low-byte) (channel 1)	A.5.2.4	A-21
FFF2h	DMABPCT0	DMA bulk packet count register (low-byte)	A.5.2.6	A-22
FFF1h	DMABPCT1	DMA bulk packet count register (high-byte)	A.5.2.7	A-22
FFF0h	DMATSL1	DMA time slot assignment register (low-byte) (channel 1)	A.5.2.1	A-20
FFEfh	DMATSH1	DMA time slot assignment register (high-byte) (channel 1)	A.5.2.2	A-21
FFEEh	DMACTL1	DMA control register (channel 1)	A.5.2.3	A-21
FFEDh	Reserved	Reserved for future use		
FFECh	DMABCNT0H	DMA current buffer content register (high-byte) (channel 0)	A.5.2.5	A-22
FFEBh	DMABCNT0L	DMA current buffer content register (low-byte) (channel 0)	A.5.2.4	A-21
FFEAh	DMATSL0	DMA time slot assignment register (low-byte) (channel 0)	A.5.2.1	A-20
FFE9h	DMATSH0	DMA time slot assignment register (high-byte) (channel 0)	A.5.2.2	A-21
FFE8h	DMACTL0	DMA control register (channel 0)	A.5.2.3	A-21
FFE7h	ACG1FRQ0	Adaptive clock generator1 frequency register (byte 0)	A.5.3.1	A-24
FFE6h	ACG1FRQ1	Adaptive clock generator1 frequency register (byte 1)	A.5.3.2	A-24
FFE5h	ACG1FRQ2	Adaptive clock generator1 frequency register (byte 2)	A.5.3.3	A-24
FFE4h	ACGCAPL	Adaptive clock generator1 MCLK capture register (low byte)	A.5.3.4	A-25
FFE3h	ACGCAPH	Adaptive clock generator1 MCLK capture register (high byte)	A.5.3.5	A-25
FFE2h	ACG1DCTL	Adaptive clock generator1 divider control register	A.5.3.10	A-26
FFE1h	ACGCTL	Adaptive clock generator control register	A.5.3.11	A-27
FFE0h	CPTCNF1	Codec port interface configuration register 1	A.5.4.1	A-27
FFDFh	CPTCNF2	Codec port interface configuration register 2	A.5.4.2	A-28
FFDEh	CPTCNF3	Codec port interface configuration register 3	A.5.4.3	A-29
FFDDh	CPTCNF4	Codec port interface configuration register 4	A.5.4.4	A-30
FFDCh	CPTCTL	Codec port interface control and status register	A.5.4.5	A-31
FFDBh	CPTADR	Codec port interface address register	A.5.4.6	A-32
FFDAh	CPTDATH	Codec port interface data register (low-byte)	A.5.4.7	A-32
FFD9h	CPTDATH	Codec port interface data register (high-byte)	A.5.4.8	A-33
FFD8h	CPTVSLH	Codec port interface valid slots register (low-byte)	A.5.4.9	A-33
FFD7h	CPTVSLH	Codec port interface valid slots register (high-byte)	A.5.4.10	A-34

**Table A–3. Memory-Mapped Registers Address Map (Continued)**

ADDRESS	MNEMONIC	NAME	SECTION	PAGE
FFD6h	CPTRXCNF2	Codec port receive interface configuration register 2	A.5.4.11	A–34
FFD5h	CPTRXCNF3	Codec port receive interface configuration register 3	A.5.4.12	A–35
FFD4h	CPTRXCNF4	Codec port receive interface configuration register 4	A.5.4.13	A–36
FFD3h	Reserved	Reserved for future use		
FFD2h	Reserved	Reserved for future use		
FFD1h	Reserved	Reserved for future use		
FFD0h	Reserved	Reserved for future use		
FFCFh	Reserved	Reserved for future use		
FFCEh	Reserved	Reserved for future use		
FFCDh	Reserved	Reserved for future use		
FFCCh	Reserved	Reserved for future use		
FFCBh	Reserved	Reserved for future use		
FFCAh	P3MSK	Mask register for P3	A.5.5.1	A–36
FFC9h	Reserved	Reserved for future use		
FFC8h	Reserved	Reserved for future use		
FFC7h	Reserved	Reserved for future use		
FFC6h	Reserved	Reserved for future use		
FFC5h	Reserved	Reserved for future use		
FFC4h	Reserved	Reserved for future use		
FFC3h	I2CADR	I <sup>2</sup> C interface address register	A.5.6.1	A–36
FFC2h	I2CDATI	I <sup>2</sup> C interface receive data register	A.5.6.2	A–37
FFC1h	I2CDATO	I <sup>2</sup> C interface transmit data register	A.5.6.3	A–37
FFC0h	I2CCTL	I <sup>2</sup> C interface control and status register	A.5.6.4	A–38
FFBFh	Reserved	Reserved for future use		
FFBEh	Reserved	Reserved for future use		
FFBDh	Reserved	Reserved for future use		
FFBCh	Ch0WrPtrL	UBM write pointer (low-byte) (8 bits)	A.5.2.8	A–22
FFBBh	Ch0WrPtrH	UBM write pointer (high-byte) (3 bits)	A.5.2.9	A–23
FFBAh	Ch0RdPtrL	DMA read pointer (low-byte) (8 bits)	A.5.2.10	A–23
FFB9h	Ch0RdPtrH	DMA read pointer (high-byte) (3 bits)	A.5.2.11	A–23
FFB8h	Ch1WrPtrL	UBM write pointer (low-byte) (8 bits)	A.5.2.8	A–22
FFB7h	Ch1WrPtrH	UBM write pointer (high-byte) (3 bits)	A.5.2.9	A–23
FFB6h	Ch1RdPtrL	DMA read pointer (low-byte) (8 bits)	A.5.2.10	A–23
FFB5h	Ch1RdPtrH	DMA read pointer (high-byte) (3 bits)	A.5.2.11	A–23
FFB4h	OEPINT	USB OUT endpoint interrupt register	A.5.7.1	A–39
FFB3h	IEPINT	USB IN endpoint interrupt register	A.5.7.2	A–39
FFB2h	VECINT	Interrupt vector register	A.5.7.3	A–40
FFB1h	GLOBCTL	Global control register	A.5.7.4	A–41
FFB0h	MEMCFG	Memory configuration register	A.5.7.5	A–41

## A.5.1 USB Registers

This section describes the memory-mapped registers used for control and operation of the USB functions. This section consists of six registers used for USB functions.

### A.5.1.1 USB Function Address Register (USBFADR – Address FFFFh)

The USB function address register contains the current setting of the USB device address assigned to the function by the host. After power-on reset or USB reset, the default address is 00h. During enumeration of the function by the host, the MCU should load the assigned address to this register when a USB Set\_Address request is received by the control endpoint.

<b>Bit</b>	<b>7</b>	<b>6</b>	<b>5</b>	<b>4</b>	<b>3</b>	<b>2</b>	<b>1</b>	<b>0</b>
<b>Mnemonic</b>	—	<b>FA6</b>	<b>FA5</b>	<b>FA4</b>	<b>FA3</b>	<b>FA2</b>	<b>FA1</b>	<b>FA0</b>
<b>Type</b>	<b>R</b>	<b>R/W</b>	<b>R/W</b>	<b>R/W</b>	<b>R/W</b>	<b>R/W</b>	<b>R/W</b>	<b>R/W</b>
<b>Default</b>	<b>0</b>	<b>0</b>	<b>0</b>	<b>0</b>	<b>0</b>	<b>0</b>	<b>0</b>	<b>0</b>

<b>BIT</b>	<b>MNEMONIC</b>	<b>NAME</b>	<b>DESCRIPTION</b>
7	—	Reserved	Reserved for future use
6:0	FA(6:0)	Function address	The function address bit values are set by the MCU to program the USB device address assigned by the host PC.

### A.5.1.2 USB Status Register (USBSTA – Address FFFEh)

The USB status register contains various status bits used for USB operations.

Bit	7	6	5	4	3	2	1	0
Mnemonic	RSTR	SUSR	RESR	SOF	PSOF	SETUP	—	STPOW
Type	R	R	R	R	R	R	R	R
Default	0	0	0	0	0	0	0	0

BIT	MNEMONIC	NAME	DESCRIPTION
7	RSTR	Function reset	The function reset bit is set to a 1 by hardware in response to the host PC initiating a USB reset to the function. When a USB reset occurs, all of the USB logic blocks, including the SIE, UBM, frame timer, and suspend/resume are automatically reset. The function reset enable (FRSTE) control bit in the USB control register, when set, enables the USB reset to reset all remaining TAS1020A logic, except the shadow the ROM (SDW) and the USB function connect (CONT) bits. Also, when the FRSTE control bit is set to a 1, the reset output (RSTO) signal from the TAS1020A device is also active when a USB reset occurs. This bit is read only and is cleared when the MCU writes to the interrupt vector register.
6	SUSR	Function suspend	The function suspend bit is set to a 1 by hardware when a USB suspend condition is detected by the suspend/resume logic. See Section 2.2.5 for details on the USB suspend and resume operation. This bit is read only and is cleared when the MCU writes to the interrupt vector register.
5	RESR	Function resume	The function resume bit is set to a 1 by hardware when a USB resume condition is detected by the suspend/resume logic. See Section 2.2.5 for details on the USB suspend and resume operation. This bit is read only and is cleared when the MCU writes to the interrupt vector register.
4	SOF	Start-of-frame	The start-of-frame bit is set to a 1 by hardware when a new USB frame starts. This bit is set when the SOF packet from the host PC is detected, even if the TAS1020A frame timer is not locked to the host PC frame timer. This bit is read only and is cleared when the MCU writes to the interrupt vector register. The nominal SOF rate is 1 ms.
3	PSOF	Pseudo start-of-frame	The pseudo start-of-frame bit is set to a 1 by hardware when a USB pseudo SOF occurs. The pseudo SOF is an artificial SOF signal that is generated when the TAS1020A frame timer is not locked to the host PC frame timer. This bit is read only and is cleared when the MCU writes to the interrupt vector register. The nominal pseudo SOF rate is 1 ms.
2	SETUP	Setup stage transaction	The setup stage transaction bit is set to a 1 by hardware when a successful control endpoint setup stage transaction is completed. Upon completion of the setup stage transaction, the USB control endpoint setup stage data packet buffer should contain a new setup stage data packet. This bit is read-only and is cleared when the MCU writes to the interrupt vector register.
1	—	Reserved	Reserved for future use
0	STPOW	Setup stage transaction over-write	The setup stage transaction over-write bit is set to a 1 by hardware when the data in the USB control endpoint setup data packet buffer is over-written. This scenario occurs when the host PC prematurely terminates a USB control transfer by simply starting a new control transfer with a new setup stage transaction. This bit is read-only and is cleared when the MCU writes to the interrupt vector register.

### A.5.1.3 USB Interrupt Mask Register (USBIMSK – Address FFFDh)

The USB interrupt mask register contains the interrupt mask bits used to enable or disable the generation of interrupts based on the corresponding status bits.

Bit	7	6	5	4	3	2	1	0
Mnemonic	RSTR	SUSR	RESR	SOF	PSOF	SETUP	—	STPOW
Type	R/W	R/W	R/W	R/W	R/W	R/W	R	R/W
Default	0	0	0	0	0	0	0	0

BIT	MNEMONIC	NAME	DESCRIPTION
7	RSTR	Function reset	The function reset interrupt mask bit is set to a 1 by the MCU to enable the USB function reset interrupt.
6	SUSR	Function suspend	The function suspend interrupt mask bit is set to a 1 by the MCU to enable the USB function suspend interrupt.
5	RESR	Function resume	The function resume interrupt mask bit is set to a 1 by the MCU to enable the USB function resume interrupt.
4	SOF	Start-of-frame	The start-of-frame interrupt mask bit is set to a 1 by the MCU to enable the USB start-of-frame interrupt.
3	PSOF	Pseudo start-of-frame	The pseudo start-of-frame interrupt mask bit is set to a 1 by the MCU to enable the USB pseudo start-of-frame interrupt.
2	SETUP	Setup stage transaction	The setup stage transaction interrupt mask bit is set to a 1 by the MCU to enable the USB setup stage transaction interrupt.
1	—	Reserved	Reserved for future use
0	STPOW	Setup stage transaction over-write	The setup stage transaction over-write interrupt mask bit is set to a 1 by the MCU to enable the USB setup stage transaction over-write interrupt.

### A.5.1.4 USB Control Register (USBCTL – Address FFFCh)

The USB control register contains various control bits used for USB operations.

Bit	7	6	5	4	3	2	1	0
Mnemonic	CONT	FEN	RWUP	FRSTE	—	—	—	SDW_OK
Type	R/W	R/W	R/W	R/W	R	R	R	R/W
Default	0	0	0	0	0	0	0	0

BIT	MNEMONIC	NAME	DESCRIPTION
7	CONT	Function connect	The function connect bit is set to 1 by the MCU to connect the TAS1020A device to the USB. As a result of connecting to the USB, the host PC should enumerate the function. When this bit is set, the USB data plus pullup resistor (PUR) output signal is enabled, which connects the pullup on the PCB to the TAS1020A 3.3-V supply voltage. When this bit is cleared to 0, the PUR output is in the high-impedance state. This bit is not affected by a USB reset.
6	FEN	Function enable	The function enable bit is set to 1 by the MCU to enable the TAS1020A device to respond to USB transactions. If this bit is cleared to 0, the UBM ignores all USB transactions. This bit is cleared by a USB reset.
5	RWUP	Remote wake-up	The remote wake-up bit is set to 1 by the MCU to request the suspend/resume logic to generate resume signaling upstream on the USB. This bit is used to exit a USB low-power suspend state when a remote wake-up event occurs. After initiating the resume signaling by setting this bit, the MCU should clear this bit within 2.5 μs.
4	FRSTE	Function reset enable	The function reset enable bit is set to 1 by the MCU to enable the USB reset to reset all internal logic including the MCU. However, the shadow the ROM (SDW) and the USB function connect (CONT) bits will not be reset. When this bit is set, the reset output (RSTO) signal from the TAS1020A device is also active when a USB reset occurs. This bit is not affected by USB reset.
3	—	Reserved	Reserved for future use.
2	—	Reserved	Reserved for future use.
1	—	Reserved	Reserved for future use.
0	SDW_OK	SDW bit confirm	This bit is used as a confirmation bit to prevent a user from spuriously clearing the SDW bit in the MEMCFG register. This bit must be set to 1 before clearing the SDW bit to switch from normal mode to boot mode. This bit is not affected by USB reset.



### A.5.1.5 USB Frame Number Register (Low Byte) (USBFNL – Address FFFBh)

The USB frame number register (low byte) contains the least significant byte of the 11-bit frame number value received from the host PC in the start-of-frame packet.

Bit	7	6	5	4	3	2	1	0
Mnemonic	FN7	FN6	FN5	FN4	FN3	FN2	FN1	FN0
Type	R	R	R	R	R	R	R	R
Default	0	0	0	0	0	0	0	0

BIT	MNEMONIC	NAME	DESCRIPTION
7:0	FN(7:0)	Frame number	The frame number bit values are updated by hardware each USB frame with the frame number field value received in the USB start-of-frame packet. The frame number can be used as a time stamp by the USB function. If the TAS1020A frame timer is not locked to the host PC frame timer, then the frame number is incremented from the previous value when a pseudo start-of-frame occurs.

### A.5.1.6 USB Frame Number Register (High Byte) (USBFNH – Address FFFAh)

The USB frame number register (high byte) contains the most significant 3 bits of the 11-bit frame number value received from the host PC in the start-of-frame packet.

Bit	7	6	5	4	3	2	1	0
Mnemonic	—	—	—	—	—	FN10	FN9	FN8
Type	R	R	R	R	R	R	R	R
Default	0	0	0	0	0	0	0	0

BIT	MNEMONIC	NAME	DESCRIPTION
7:3	—	Reserved	Reserved for future use.
2:0	FN(10:8)	Frame number	The frame number bit values are updated by hardware each USB frame with the frame number field value received in the USB start-of-frame packet. The frame number can be used as a time stamp by the USB function. If the TAS1020A frame timer is not locked to the host PC frame timer, then the frame number is incremented from the previous value when a pseudo start-of-frame occurs.

## A.5.2 DMA Registers

This section describes the memory-mapped registers used for the two DMA channels. Each DMA channel has a set of three registers.

### A.5.2.1 DMA Time Slot Assignment Register (Low Byte) (DMATSL1 – Address FFF0h) (DMATSL0 – Address FFEAh)

Bit	7	6	5	4	3	2	1	0
Mnemonic	TSL7	TSL6	TSL5	TSL4	TSL3	TSL2	TSL1	TSL0
Type	R/W	R/W	R/W	R/W	R/W	R/W	R/W	R/W
Default	0	0	0	0	0	0	0	0

BIT	MNEMONIC	NAME	DESCRIPTION
7:0	TSL(7:0)	Time slot assignment	The DMA time slot assignment bits are set to 1 by the MCU to define the codec port interface time slots supported by this DMA channel.

A.5.2.2 DMA Time Slot Assignment Register (High Byte) (DMATSH1 – Address FFEFh)  
(DMATSH0 – Address 0xFFE9)

Bit	7	6	5	4	3	2	1	0
Mnemonic	BPTS1	BPTS0	TSL13	TSL12	TSL11	TSL10	TSL9	TSL8
Type	R/W	R/W	R/W	R/W	R/W	R/W	R/W	R/W
Default	0	0	0	0	0	0	0	0

BIT	MNEMONIC	NAME	DESCRIPTION
7:6	BPTS(1:0)	Bytes per time slot	The bytes per time slot bits are used to define the number of bytes to be transferred for each time slot supported by this DMA channel. 00b = 1 byte, 01b = 2 bytes, 10b = 3 bytes, 11b = 4 bytes
5:0	TSL(13:8)	Time slot assignment	The DMA time slot assignment bits are set to 1 by the MCU to define the codec port interface time slots supported by this DMA channel.

A.5.2.3 DMA Control Register (DMACTL1 – Address FFEEh) (DMACTL0 – Address FFE8h)

Bit	7	6	5	4	3	2	1	0
Mnemonic	DMAEN	HSKEN	—	—	EPDIR	EPNUM2	EPNUM1	EPNUM0
Type	R/W	R/W	R	R	R/W	R/W	R/W	R/W
Default	0	0	0	0	0	0	0	0

BIT	MNEMONIC	NAME	DESCRIPTION
7	DMAEN	DMA enable	The DMA enable bit is set to a 1 by the MCU to enable this DMA channel. Before enabling the DMA channel, all other DMA channel configuration bits must be set to the desired value.
6	HSKEN	Handshake enable	This bit is relevant for BULK data transfer in the OUT direction through DMA. MCU must set this bit to a 1 to enable the handshake mode for the data transfer. If MCU sets this bit, MCU has to enable DMA for each received BULK OUT packet. DMA, once enabled, transfers the BULK OUT packet to the C-port, disables itself and generates an interrupt to the MCU. If MCU clears this bit, DMA handles the BULK OUT data transfer to the C-port without MCU intervention. For more details, see Section 2.2.7.3.3.
5	—	Reserved	Reserved for future use
4	—	Reserved	Reserved for future use
3	EPDIR	USB endpoint direction	The USB endpoint direction bit controls the direction of data transfer by this DMA channel. The MCU should set this bit to a 1 to configure this DMA channel to be used for a USB IN endpoint. The MCU must clear this bit to a 0 to configure this DMA channel to be used for a USB OUT endpoint.
2:0	EPNUM(2:0)	USB endpoint number	The USB endpoint number bits are set by the MCU to define the USB endpoint number supported by this DMA channel. Keep in mind that endpoint 0 is always used for the control endpoint, which is serviced by the MCU and not a DMA channel. 001b = Endpoint 1, 010b = Endpoint 2, ..., 111b = Endpoint 7, 000b = Illegal

A.5.2.4 DMA Current Buffer Content Register (Low-Byte) (DMABCNT1L – Address FFF3h)  
(DMABCNT0L – Address FFEb)

Bit	7	6	5	4	3	2	1	0
Mnemonic	Size 7	Size 6	Size 5	Size 4	Size 3	Size 2	Size 1	Size 0
Type	R	R	R	R	R	R	R	R
Default	0	0	0	0	0	0	0	0

BIT	MNEMONIC	NAME	DESCRIPTION
7:0	Size(7:0)	Buffer content	This register shows the buffer content (bytes) for an ISO OUT endpoint. This register is updated every SOF and is stable for the following USB frame, during which the MCU can read it to implement USB audio synchronization.

A.5.2.5 DMA Current Buffer Content Register (High Byte) (DMABCNT1H – Address FFF4h)  
(DMABCNT0H – Address FFECh)

Bit	7	6	5	4	3	2	1	0
Mnemonic	Size 15	Size 14	Size 13	Size 12	Size 11	Size 10	Size 9	Size 8
Type	R	R	R	R	R	R	R	R
Default	0	0	0	0	0	0	0	0

BIT	MNEMONIC	NAME	DESCRIPTION
7:0	Size(15:8)	Buffer content	This register shows the buffer content (bytes) for an ISO OUT endpoint. This register is updated every SOF and is stable for the following USB frame, during which the MCU can read it to implement USB audio synchronization.

A.5.2.6 DMA Bulk Packet Count Register (Low Byte) (DMABPCT0 – Address FFF2h)

Bit	7	6	5	4	3	2	1	0
Mnemonic	PCNT7	PCNT6	PCNT5	PCNT4	PCNT3	PCNT2	PCNT1	PCNT0
Type	R/W	R/W	R/W	R/W	R/W	R/W	R/W	R/W
Default	0	0	0	0	0	0	0	0

BIT	MNEMONIC	NAME	DESCRIPTION
7:0	PCNT (7:0)	Bulk packet count	This register shows the number of BULK OUT packets DMA has to handle in handshake mode. MCU writes to this register before enabling the DMA to program the DMA to handle up to 64K BULK packets without MCU intervention. MCU can read this register anytime.

A.5.2.7 DMA Bulk Packet Count Register (High-byte) (DMABPCT1 – Address FFF1h)

Bit	7	6	5	4	3	2	1	0
Mnemonic	PCNT15	PCNT14	PCNT13	PCNT12	PCNT11	PCNT10	PCNT9	PCNT8
Type	R/W	R/W	R/W	R/W	R/W	R/W	R/W	R/W
Default	0	0	0	0	0	0	0	0

BIT	MNEMONIC	NAME	DESCRIPTION
7:0	PCNT (15:8)	Bulk packet count	This register shows the number of BULK OUT packets DMA has to handle in handshake mode. MCU writes to this register before enabling the DMA to program the DMA to handle up to 64K BULK packets without MCU intervention. MCU can read this register anytime.

A.5.2.8 UBM Write Pointer (Low Byte) (Ch0WrPtrL – Address FFBCh) (Ch1WrPtrL – Address FFB8h)

Bit	7	6	5	4	3	2	1	0
Mnemonic	WRPTR7	WRPTR6	WRPTR5	WRPTR4	WRPTR3	WRPTR2	WRPTR1	WRPTR0
Type	R	R	R	R	R	R	R	R
Default	0	0	0	0	0	0	0	0

BIT	MNEMONIC	NAME	DESCRIPTION
7:0	WRPTR(7:0)	UBM Write Pointer	This register contains 8 LSB bits of 11-bit UBM Write Pointer of the isochronous OUT endpoint buffer. MCU can read this register anytime. This 11-bit UBM Write Pointer WRPTR can be used in conjunction with the corresponding 11-bit CHn DMA RDPTR to estimate the amount of data in the isochronous OUT endpoint buffer.

A.5.2.9 UBM Write Pointer (High Byte) (Ch0WrPtrH – Address FFBBh)  
(Ch1WrPtrH – Address FFB7h)

Bit	7	6	5	4	3	2	1	0
Mnemonic	—	—	—	—	—	WRPTR10	WRPTR9	WRPTR8
Type	—	—	—	—	—	R	R	R
Default	—	—	—	—	—	0	0	0

BIT	MNEMONIC	NAME	DESCRIPTION
2:0	WRPTR(10:8)	UBM Write Pointer	This register contains 3 MSB bits of 11-bit UBM Write Pointer of the isochronous OUT endpoint buffer. MCU can read this register anytime. This 11-bit UBM Write Pointer WRPTR can be used in conjunction with the corresponding 11-bit CHn DMA RDPTR to estimate the amount of data in the isochronous OUT endpoint buffer.
7:3	—	Reserved	Reserved for future use

A.5.2.10 DMA Read Pointer (Low Byte) (Ch0RdPtrL – Address FFBAh) (Ch1RdPtrL – Address FFB6h)

Bit	7	6	5	4	3	2	1	0
Mnemonic	RDPTR7	RDPTR6	RDPTR5	RDPTR4	RDPTR3	RDPTR2	RDPTR1	RDPTR0
Type	R	R	R	R	R	R	R	R
Default	0	0	0	0	0	0	0	0

BIT	MNEMONIC	NAME	DESCRIPTION
7:0	RDPTR(7:0)	DMA Read Pointer	This register contains 8 LSB bits of 11-bit DMA channel n (n can be 0 or 1) Read Pointer of the Isochronous OUT endpoint buffer. MCU can read this register anytime. This 11-bit CHn DMA Read pointer RDPTR can be used in conjunction with the corresponding 11-bit UBM Write Pointer WRPTR to estimate the amount of data in the isochronous OUT endpoint buffer.

A.5.2.11 DMA Read Pointer (High Byte) (Ch0RdPtrH – Address FFB9h)  
(Ch1RdPtrH – Address FFB5h)

Bit	7	6	5	4	3	2	1	0
Mnemonic	—	—	—	—	—	WRPTR10	WRPTR9	WRPTR8
Type	—	—	—	—	—	R	R	R
Default	—	—	—	—	—	0	0	0

BIT	MNEMONIC	NAME	DESCRIPTION
2:0	RDPTR(10:8)	DMA Read Pointer	This register contains 3 MSB bits of 11-bit channel n (n can be 0 or 1) Read Pointer of the Isochronous OUT endpoint buffer. MCU can read this register anytime. This 11-bit CHn DMA RDPTR can be used in conjunction with the corresponding 11-bit UBM Write Pointer WRPTR to estimate the amount of data in the isochronous OUT endpoint buffer.
7:3	—	Reserved	Reserved for future use

### A.5.3 Adaptive Clock Generator Registers

This section describes the memory-mapped registers used for two adaptive clock generators for their controls and operations.

#### A.5.3.1 Adaptive Clock Generator1 Frequency Register (Byte 0) (ACG1FRQ0 – Address FFE7h)

The adaptive clock generator frequency register (byte 0) contains the least significant byte of the 24-bit ACG frequency value. The adaptive clock generator frequency registers, ACG1FRQ0, ACG1FRQ1, and ACG1FRQ2, contain the 24-bit value used to program the ACG1 frequency synthesizer. The 24-bit value of these three registers can be used to determine the codec master clock output (MCLKO) signal frequency. The output of the ACG2 frequency synthesizer can also be used to source MCLK0. See Section 2.2.6 for the operation details of the adaptive clock generator including instructions for programming the 24-bit ACG frequency value.

Bit	7	6	5	4	3	2	1	0
Mnemonic	FRQ7	FRQ6	FRQ5	FRQ4	FRQ3	FRQ2	FRQ1	FRQ0
Type	R/W	R/W	R/W	R/W	R/W	R/W	R/W	R/W
Default	0	0	0	0	0	0	0	0

BIT	MNEMONIC	NAME	DESCRIPTION
7:0	FRQ(7:0)	ACG frequency	The ACG frequency bit values are set by the MCU to program the ACG1 frequency synthesizer.

#### A.5.3.2 Adaptive Clock Generator1 Frequency Register (Byte 1) (ACG1FRQ1 – Address FFE6h)

The adaptive clock generator frequency register (byte 1) contains the middle byte of the 24-bit ACG 1 frequency value.

Bit	7	6	5	4	3	2	1	0
Mnemonic	FRQ15	FRQ14	FRQ13	FRQ12	FRQ11	FRQ10	FRQ9	FRQ8
Type	R/W	R/W	R/W	R/W	R/W	R/W	R/W	R/W
Default	0	0	0	0	0	0	0	0

BIT	MNEMONIC	NAME	DESCRIPTION
7:0	FRQ(15:8)	ACG frequency	The ACG frequency bit values are set by the MCU to program the ACG1 frequency synthesizer.

#### A.5.3.3 Adaptive Clock Generator1 Frequency Register (Byte 2) (ACG1FRQ2 – Address FFE5h)

The adaptive clock generator frequency register (byte 2) contains the most significant byte of the 24-bit ACG frequency value.

Bit	7	6	5	4	3	2	1	0
Mnemonic	FRQ23	FRQ22	FRQ21	FRQ20	FRQ19	FRQ18	FRQ17	FRQ16
Type	R/W	R/W	R/W	R/W	R/W	R/W	R/W	R/W
Default	0	0	0	0	0	0	0	0

BIT	MNEMONIC	NAME	DESCRIPTION
7:0	FRQ(23:16)	ACG frequency	The ACG frequency bit values are set by the MCU to program the ACG1 frequency synthesizer.

#### A.5.3.4 Adaptive Clock Generator MCLK Capture Register (Low Byte) (ACGCAPL – Address FFE4h)

The adaptive clock generator MCLK capture register (low byte) contains the least significant byte of the 16-bit codec master clock (MCLK) signal cycle count that is captured each time a USB start of frame (SOF) occurs. The value of a 16-bit free running counter, which is clocked with the MCLK signal, is captured at the beginning of each USB frame. The source of the MCLK signal used to clock the 16-bit timer can be selected to be either the MCLKO signal or the MCLKO2 signal. See Section 2.2.6 for the operation details of the adaptive clock generator.

Bit	7	6	5	4	3	2	1	0
Mnemonic	CAP7	CAP6	CAP5	CAP4	CAP3	CAP2	CAP1	CAP0
Type	R	R	R	R	R	R	R	R
Default	0	0	0	0	0	0	0	0

BIT	MNEMONIC	NAME	DESCRIPTION
7:0	CAP(7:0)	ACG MCLK capture	The ACG MCLK capture bit values are updated by hardware each time a USB start of frame occurs. This register contains the least significant byte of the 16-bit value.

#### A.5.3.5 Adaptive Clock Generator MCLK Capture Register (High Byte) (ACGCAPH – Address FFE3h)

The adaptive clock generator MCLK capture register (high byte) contains the most significant byte of the 16-bit codec master clock (MCLK) signal cycle count that is captured each time a USB start of frame (SOF) occurs.

Bit	7	6	5	4	3	2	1	0
Mnemonic	CAP15	CAP14	CAP13	CAP12	CAP11	CAP10	CAP9	CAP8
Type	R	R	R	R	R	R	R	R
Default	0	0	0	0	0	0	0	0

BIT	MNEMONIC	NAME	DESCRIPTION
7:0	CAP(15:8)	ACG MCLK capture	The ACG MCLK capture bit values are updated by hardware each time a USB start of frame occurs. This register contains the most significant byte of the 16-bit value.

#### A.5.3.6 Adaptive Clock Generator2 Frequency Register (Byte 0) (ACG2FRQ0 – Address FFF9h)

The adaptive clock generator control registers ACG2FRQ0, ACG2FRQ1, and ACG2FRQ2, contain the 24-bit value used to program the ACG2 frequency synthesizer.

Bit	7	6	5	4	3	2	1	0
Mnemonic	FRQ7	FRQ6	FRQ5	FRQ4	FRQ3	FRQ2	FRQ1	FRQ0
Type	R/W	R/W	R/W	R/W	R/W	R/W	R/W	R/W
Default	0	0	0	0	0	0	0	0

BIT	MNEMONIC	NAME	DESCRIPTION
7:0	FRQ(7:0)	ACQ2 frequency	The ACG2 frequency bit values are set by the MCU to program the ACG2 frequency synthesizer.

#### A.5.3.7 Adaptive Clock Generator2 Frequency Register (Byte 1) (ACG2FRQ1 – Address FFF8h)

Bit	7	6	5	4	3	2	1	0
Mnemonic	FRQ15	FRQ14	FRQ13	FRQ12	FRQ11	FRQ10	FRQ9	FRQ8
Type	R/W	R/W	R/W	R/W	R/W	R/W	R/W	R/W
Default	0	0	0	0	0	0	0	0

BIT	MNEMONIC	NAME	DESCRIPTION
7:0	FRQ(15:8)	ACQ2 frequency	The ACG2 frequency bit values are set by the MCU to program the ACG2 frequency synthesizer.

### A.5.3.8 Adaptive Clock Generator2 Frequency Register (Byte 2) (ACG2FRQ2 – Address FFF7h)

Bit	7	6	5	4	3	2	1	0
Mnemonic	FRQ23	FRQ22	FRQ21	FRQ20	FRQ19	FRQ18	FRQ17	FRQ16
Type	R/W	R/W	R/W	R/W	R/W	R/W	R/W	R/W
Default	0	0	0	0	0	0	0	0

BIT	MNEMONIC	NAME	DESCRIPTION
7:0	FRQ(23:16)	ACQ2 frequency	The ACG2 frequency bit values are set by the MCU to program the ACG2 frequency synthesizer.

### A.5.3.9 Adaptive Clock Generator2 Divider Control Register (ACG2DCTL – Address FFF6h)

Bit	7	6	5	4	3	2	1	0
Mnemonic	DIVM3	DIVM2	DIVM1	DIVM0	–	–	–	–
Type	R/W	R/W	R/W	R/W	R	R	R	R
Default	0	0	0	0	0	0	0	0

BIT	MNEMONIC	NAME	DESCRIPTION
7:4	DIVM(3:0)	Divide by M value	The divide by M control bits are set by the MCU to program the ACG2 frequency divider. 0000b = divide by 1, 0001b = divide by 2, ... 1111b = divide by 16
3:0	–	Reserved	Reserved for future use

### A.5.3.10 Adaptive Clock Generator1 Divider Control Register (ACG1DCTL – Address FFE2h)

Bit	7	6	5	4	3	2	1	0
Mnemonic	DIVM3	DIVM2	DIVM1	DIVM0	–	DIVI2	DIVI1	DIVIO
Type	R/W	R/W	R/W	R/W	R	R/W	R/W	R/W
Default	0	0	0	0	0	0	0	0

BIT	MNEMONIC	NAME	DESCRIPTION
7:4	DIVM(3:0)	Divide by M value	The divide by M control bits are set by the MCU to program the ACG1 frequency divider. 0000b = divide by 1, 0001b = divide by 2, ... 1111b = divide by 16
3	–	Reserved	Reserved for future use
2:0	DIVI(2:0)	Divide by I value	The divide by I control bits are set by the MCU to program the MCLKI divider. 000b = divide by 1, 001b = divide by 2, ..., 111b = divide by 8

### A.5.3.11 Adaptive Clock Generator Control Register (ACGCTL – Address FFE1h)

Bit	7	6	5	4	3	2	1	0
Mnemonic	MCLKO2EN	MCLKO1EN	–	MCLKO1S1	MCLKO1S0	DIVEN	MCLKO2S1	MCLKO2S0
Type	R/W	R/W	R	R/W	R/W	R/W	R/W	R/W
Default	0	0	0	0	0	0	0	0

BIT	MNEMONIC	NAME	DESCRIPTION																
7	MCLKO2EN	MCLKO2 Output enable	This bit is set to 1 by the MCU to enable the MCLKO2 signal to be an output from the TAS1020A device. If the MCLKO2 signal is not being used, then the MCU can clear this bit to 0 to set the output to logic 0.																
6	MCLKO1EN	MCLKO1 Output enable	This bit is set to 1 by the MCU to enable the MCLKO1 signal to be an output from the TAS1020A device. If the MCLKO1 signal is not being used, then the MCU can clear this bit to 0 to set the output to logic 0.																
5	–	Reserved	Reserved for future use																
4	MCLKO1S1	MCLKO1 Clock select	This bit in conjunction with MCLKO1S0, selects the source for MCLKO1. Refer to ACG block diagram. <table style="margin-left: auto; margin-right: auto;"> <tr> <td></td> <td>MCLKO1S1</td> <td>MCLKO1S0</td> <td>MCLKO1</td> </tr> <tr> <td></td> <td>0</td> <td>0</td> <td>acg_clk (after +M)</td> </tr> <tr> <td></td> <td>x</td> <td>1</td> <td>mclki (after -I)</td> </tr> <tr> <td></td> <td>1</td> <td>0</td> <td>acg2_clk(after +M)</td> </tr> </table>		MCLKO1S1	MCLKO1S0	MCLKO1		0	0	acg_clk (after +M)		x	1	mclki (after -I)		1	0	acg2_clk(after +M)
	MCLKO1S1	MCLKO1S0	MCLKO1																
	0	0	acg_clk (after +M)																
	x	1	mclki (after -I)																
	1	0	acg2_clk(after +M)																
3	MCLKO1S0	MCLKO1 Clock select	Refer to the description above.																
2	DIVEN	Divider Enable	The Divider Enable bit is set to 1 by the MCU to enable the Divide-by-I and Divide-by-M circuits.																
1	MCLKO2S1	MCLKO2 Clock select	This bit in conjunction with MCLKO2S0, selects the MCLKO2. Refer to ACG block diagram. <table style="margin-left: auto; margin-right: auto;"> <tr> <td></td> <td>MCLKO2S1</td> <td>MCLKO2S0</td> <td>MCLKO2</td> </tr> <tr> <td></td> <td>0</td> <td>0</td> <td>acg_clk (after +M)</td> </tr> <tr> <td></td> <td>x</td> <td>1</td> <td>mclki (after -I)</td> </tr> <tr> <td></td> <td>1</td> <td>0</td> <td>acg2_clk(after +M)</td> </tr> </table>		MCLKO2S1	MCLKO2S0	MCLKO2		0	0	acg_clk (after +M)		x	1	mclki (after -I)		1	0	acg2_clk(after +M)
	MCLKO2S1	MCLKO2S0	MCLKO2																
	0	0	acg_clk (after +M)																
	x	1	mclki (after -I)																
	1	0	acg2_clk(after +M)																
0	MCLKO2S0	MCLKO2 Clock select	Refer to the description above.																

### A.5.4 Codec Port Interface Registers

This section describes the memory-mapped registers used for the codec port interface control and operation. The codec port interface has a set of ten registers. Note that the four codec port interface configuration registers can only be written to by the MCU if the codec port enable bit (CPTEN) in the global control register is a 0 – the codec port is disabled.



#### A.5.4.1 Codec Port Interface Configuration Register 1 (CPTCNF1 – Address FFE0h)

The codec port interface configuration register 1 is used to store various control bits for the codec port interface operation.

Bit	7	6	5	4	3	2	1	0
Mnemonic	NTSL4	NTSL3	NTSL2	NTSL1	NTSL0	MODE2	MODE1	MODE0
Type	R/W	R/W	R/W	R/W	R/W	R/W	R/W	R/W
Default	0	0	0	0	0	0	0	0

BIT	MNEMONIC	NAME	DESCRIPTION
7:3	NTSL(4:0)	Number of time slots	The number of time slots bits are set by the MCU to program the number of time slots per audio frame. 00000b = illegal, 00001b = 2 time slots per frame, ..., 01101 = 14 time slots per frame
2:0	MODE(2:0)	Mode select	The mode select bits are set by the MCU to program the codec port interface mode of operation. In addition to selecting the desired mode of operation, the MCU must also program the other configuration registers to obtain the correct serial interface format. 000b = mode 0 - General-purpose mode 001b = mode 1 - AIC mode 010b = mode 2 - AC '97 1.X mode 011b = mode 3 - AC '97 2.X mode 100b = mode 4 - I <sup>2</sup> S mode – 1 OUT and 2 IN at same frequency 101b = mode 5 - I <sup>2</sup> S mode – 1 OUT and 1 IN at different frequencies 110b = reserved 111b = reserved

### A.5.4.2 Codec Port Interface Configuration Register 2 (CPTCNF2 – Address FFDFh)

The codec port interface configuration register 2 is used to store various control bits for the codec port interface operation.

Bit	7	6	5	4	3	2	1	0
Mnemonic	TSL0L1	TSL0L0	BPTSL2	BPTSL1	BPTSL0	TSL2	TSL1	TSL0
Type	R/W	R/W	R/W	R/W	R/W	R/W	R/W	R/W
Default	0	0	0	0	0	0	0	0

BIT	MNEMONIC	NAME	DESCRIPTION
7:6	TSL0L(1:0)	Time slot 0 length	The time slot 0 Length bits are set by the MCU to program the number of serial clock (CSCLK) cycles for time slot 0. 00b = CSCLK cycles for time slot 0 same as other time slots 01b = 8 CSCLK cycles for time slot 0 10b = 16 CSCLK cycles for time slot 0 11b = 32 CSCLK cycles for time slot 0
5:3	BPTSL(2:0)	Data bits per time slot	The data bits per time slot bits are set by the MCU to program the number of data bits per audio time slot. Note that this value is not used for the secondary communication address and data time slots. 000b = 8 data bits per time slot 001b = 16 data bits per time slot 010b = 18 data bits per time slot 011b = 20 data bits per time slot 100b = 24 data bits per time slot 101b = 32 data bits per time slot 110b = reserved 111b = reserved
2:0	TSL(2:0)	Time slot length	The time slot length bits are set by the MCU to program the number of serial clock (CSCLK) cycles for all time slots except time slot 0. 000b = 8 CSCLK cycles per time slot 001b = 16 CSCLK cycles per time slot 010b = 18 CSCLK cycles per time slot 011b = 20 CSCLK cycles per time slot 100b = 24 CSCLK cycles per time slot 101b = 32 CSCLK cycles per time slot 110b = reserved 111b = reserved

### A.5.4.3 Codec port interface configuration register 3 (CPTCNF3 – Address FFDEh)

The codec port interface configuration register 3 is used to store various control bits for the codec port interface operation.

Bit	7	6	5	4	3	2	1	0
Mnemonic	DDL <sub>Y</sub>	TRSEN	CSCLKP	CSYNCP	CSYNCL	BYOR	CSCLKD	CSYNCD
Type	R/W	R/W	R/W	R/W	R/W	R/W	R/W	R/W
Default	0	0	1	1	0	0	0	0

BIT	MNEMONIC	NAME	DESCRIPTION
7	DDL <sub>Y</sub>	Data delay	The data delay bit is set to a 1 by the MCU to program a one CSCLK cycle delay of the serial data output and input signals in reference to the leading edge of the CSYNC signal. The MCU must clear this bit to a 0 for no delay between these signals.
6	TRSEN	3-State enable	The 3-state enable bit is set to a 1 by the MCU to program the hardware to set the serial data output signal to the high-impedance state for the time slots during the audio frame that are not valid. The MCU must clear this bit to a 0 to program the hardware to use zero-padding for the serial data output signal for time slots during the audio frame that are not valid.
5	CSCLKP	CSCLK polarity	The CSCLK polarity bit is used by the MCU to program the clock edge used for the codec port interface frame sync (CSYNC) output signal, codec port interface serial data output (CDATO) signal and codec port interface serial data Input (CDATI) signal. When this bit is set to a 1, the CSYNC signal is generated with the negative edge of the codec port interface serial clock (CSCLK) signal. Also, when this bit is set to a 1, the CDATO signal is generated with the negative edge of the CSCLK signal and the CDATI signal is sampled with the positive edge of the CSCLK signal. When this bit is cleared to a 0, the CSYNC signal is generated with the positive edge of the CSCLK signal. Also, when this bit is cleared to a 0, the CDATO signal is generated with the positive edge of the CSCLK signal and the CDATI signal is sampled with the negative edge of the CSCLK signal.
4	CSYNCP	CSYNC polarity	The CSYNC polarity bit is set to a 1 by the MCU to program the polarity of the codec port interface frame sync (CSYNC) output signal to be active high. The MCU must clear this bit to a 0 to program the polarity of the CSYNC output signal to be active low.
3	CSYNCL	CSYNC length	The CSYNC length bit is set to a 1 by the MCU to program the length of the codec port interface frame sync (CSYNC) output signal to be the same number of CSCLK cycles as time slot 0. The MCU must clear this bit to a 0 to program the length of the CSYNC output signal to be one CSCLK cycle.
2	BYOR	Byte order	The byte order bit is used by the MCU to program the byte order for the data moved by the DMA between the USB endpoint buffer and the codec port interface. When this bit is set to a 1, the byte order of each audio sample is reversed when the data is moved to/from the USB endpoint buffer. When this bit is cleared to a 0, the byte order of the each audio sample is unchanged.
1	CSCLKD	CSCLK direction	The CSCLK direction bit is set to a 1 by the MCU to program the direction of the codec port interface serial clock (CSCLK) signal as an input to the TAS1020A device. The MCU must clear this bit to a 0 to program the direction of the CSCLK signal as an output from the TAS1020A device.
0	CSYNCD	CSYNC direction	The CSYNC direction bit is set to a 1 by the MCU to program the direction of the codec port interface frame sync (CSYNC) signal as an input to the TAS1020A device. The MCU must clear this bit to a 0 to program the direction of the CSYNC signal as an output from the TAS1020A device.

#### A.5.4.4 Codec Port Interface Configuration Register 4 (CPTCNF4 – Address FFDDh)

The codec port interface configuration register 4 is used to store various control bits for the codec port interface operation.

<b>Bit</b>	<b>7</b>	<b>6</b>	<b>5</b>	<b>4</b>	<b>3</b>	<b>2</b>	<b>1</b>	<b>0</b>
<b>Mnemonic</b>	<b>ATSL3</b>	<b>ATSL2</b>	<b>ATSL1</b>	<b>ATSL0</b>	<b>CPTBLK</b>	<b>DIVB2</b>	<b>DIVB1</b>	<b>DIVB0</b>
<b>Type</b>	<b>R/W</b>	<b>R/W</b>	<b>R/W</b>	<b>R/W</b>	<b>R/W</b>	<b>R/W</b>	<b>R/W</b>	<b>R/W</b>
<b>Default</b>	<b>0</b>	<b>0</b>	<b>0</b>	<b>0</b>	<b>0</b>	<b>0</b>	<b>0</b>	<b>0</b>

<b>BIT</b>	<b>MNEMONIC</b>	<b>NAME</b>	<b>DESCRIPTION</b>
7:4	ATSL(3:0)	Command/status address/data time slot	The command/status address/data time slot bits are set by the MCU to program the time slots to be used for the secondary communication address and data values. For the AC '97 modes of operation, this value must be set to 0001b which results in time slot 1 being used for the address and time slot 2 being used for the data. For the AIC and general-purpose modes of operation, the same time slot is used for both address and data. For the AIC mode of operation this value must be set to 0111b which results in time slot 7 being used for both the address and data. 0000b = time slot 0, 0001b = time slot 1, ..., 1111b = time slot 15
3	CptBlk	C-port bulk mode	This bit is used when C-port is in Mode 0. If this bit is cleared to 0, the C-port sync/clocks are free running once C-port is enabled. If this bit is set to 1, DMA controls the C-port sync/clocks. The sync/clocks are active only when valid data is present in a codec frame.
2:0	DIVB(2:0)	Divide by B value	The divide by B control bits are set by the MCU to program the divide ratio used to derive CSCLK from MCLKO. 000b = CSCLK output disabled 001b = divide by 2 010b = divide by 3 011b = divide by 4 100b = divide by 5 101b = divide by 6 110b = divide by 7 111b = divide by 8

#### A.5.4.5 Codec Port Interface Control and Status Register (CPTCTL – Address FFDCh)

The codec port interface control and status register contains various control and status bits used for the codec port interface operation.

Bit	7	6	5	4	3	2	1	0
Mnemonic	RXF	RXIE	TXE	TXIE	—	CID1	CID0	CRST
Type	R	R/W	R	R/W	R	R/W	R/W	R/W
Default	0	0	0	0	0	0	0	0

BIT	MNEMONIC	NAME	DESCRIPTION
7	RXF	Receive data register full	The receive data register full bit is set to a 1 by hardware when a new data value has been received into the receive data register from the codec device. This bit is read only and is cleared to a 0 by hardware when the MCU reads the new value from the receive data register. Note that when the MCU writes to the interrupt vector register, the codec port interface receive data register full interrupt is cleared but this status bit is not cleared at that time.
6	RXIE	Receive interrupt enable	The receive interrupt enable bit is set to a 1 by the MCU to enable the C-port receive data register full interrupt.
5	TXE	Transmit data register empty	The transmit data register empty bit is set to a 1 by hardware when the data value in the transmit data register has been sent to the codec device. This bit is read only and is cleared to a 0 by hardware when a new data byte is written to the transmit data register by the MCU. Note that when the MCU writes to the interrupt vector register, the codec port interface transmit data register empty interrupt is cleared but this status bit is not cleared at that time.
4	TXIE	Transmit interrupt enable	The transmit interrupt enable bit is set to a 1 by the MCU to enable the codec port interface transmit data register empty interrupt.
3	—	Reserved	Reserved for future use
2:1	CID(1:0)	Codec ID	The codec ID bits are used by the MCU to select between the primary codec device and the secondary codec device for secondary communication in the AC '97 modes of operation. When the bits are cleared to 00, the primary codec device is selected. When the bits are set to 01, 10 or 11, the secondary codec device is selected. Note that when only a primary codec device is connected to the TAS1020A, the bits remain cleared to 00.
0	CRST	Codec reset	The codec reset bit is used by the MCU to control the codec port interface reset ( <u>CRESET</u> ) output signal from the TAS1020A device. When this bit is set to a 1, the <u>CRESET</u> signal is a high. When this bit is cleared to a 0, the <u>CRESET</u> signal is active low. At power up this bit is cleared to a 0, which means the <u>CRESET</u> output signal is active low and remains active low until the MCU sets this bit to a 1. In I <sup>2</sup> S mode 5, this signal is not available because the <u>CRESET</u> pin becomes SCLK2, which is used to input data from a codec.

#### A.5.4.6 Codec Port Interface Address Register (CPTADR – Address FFDBh)

The codec port interface address register contains the read/write control bit and address bits used for secondary communication between the TAS1020A MCU and the codec device. For write transactions to the codec, the 8-bit value in this register is sent to the codec in the designated time slot and appropriate bit locations. Note that for the different modes of operation, the number of address bits and the bit location of the read/write bit is different. For example, the AC '97 modes require 7 address bits and the bit location of the read/write bit to be the most significant bit. The AIC mode only requires 4 address bits and the bit location of the read/write bit to be bit 13 of the 16-bits in the time slot. The MCU must load the read/write and address bits to the correct bit locations within this register for the different modes of operation. Shown below are the read/write control bit and address bits for the AC '97 mode of operation.

<b>Bit</b>	<b>7</b>	<b>6</b>	<b>5</b>	<b>4</b>	<b>3</b>	<b>2</b>	<b>1</b>	<b>0</b>
<b>Mnemonic</b>	<b>R/W</b>	<b>A6</b>	<b>A5</b>	<b>A4</b>	<b>A3</b>	<b>A2</b>	<b>A1</b>	<b>A0</b>
<b>Type</b>	<b>R/W</b>	<b>R/W</b>	<b>R/W</b>	<b>R/W</b>	<b>R/W</b>	<b>R/W</b>	<b>R/W</b>	<b>R/W</b>
<b>Default</b>	<b>0</b>	<b>0</b>	<b>0</b>	<b>0</b>	<b>0</b>	<b>0</b>	<b>0</b>	<b>0</b>

<b>BIT</b>	<b>MNEMONIC</b>	<b>NAME</b>	<b>DESCRIPTION</b>
7	R/W	Command/status read/write control	The command/status read/write control bit value is set by the MCU to program the type of secondary communication transaction to be done. This bit must be set to a 1 by the MCU for a read transaction and cleared to a 0 by the MCU for a write transaction.
6:0	A(6:0)	Command/status address	The command/status address value is set by the MCU to program the codec device control/status register address to be accessed during the read or write transaction. The command/status address value is updated by hardware with the control/status register address value received from the codec device for read transactions.

#### A.5.4.7 Codec Port Interface Data Register (Low Byte) (CPTDATL – Address FFDAh)

The codec port interface data register (low byte) contains the least significant byte of the 16-bit command or status data value used for secondary communication between the TAS1020A MCU and the codec device. Note that for general-purpose mode or AIC mode only an 8-bit data value is used for secondary communication.

<b>Bit</b>	<b>7</b>	<b>6</b>	<b>5</b>	<b>4</b>	<b>3</b>	<b>2</b>	<b>1</b>	<b>0</b>
<b>Mnemonic</b>	<b>D7</b>	<b>D6</b>	<b>D5</b>	<b>D4</b>	<b>D3</b>	<b>D2</b>	<b>D1</b>	<b>D0</b>
<b>Type</b>	<b>R/W</b>	<b>R/W</b>	<b>R/W</b>	<b>R/W</b>	<b>R/W</b>	<b>R/W</b>	<b>R/W</b>	<b>R/W</b>
<b>Default</b>	<b>0</b>	<b>0</b>	<b>0</b>	<b>0</b>	<b>0</b>	<b>0</b>	<b>0</b>	<b>0</b>

<b>BIT</b>	<b>MNEMONIC</b>	<b>NAME</b>	<b>DESCRIPTION</b>
7:0	D(7:0)	Command/status data	The command/status data value is set by the MCU with the command data to be transmitted to the codec device for write transactions. The command/status data value is updated by hardware with the status data received from the codec device for read transactions.

#### A.5.4.8 Codec Port Interface Data Register (High Byte) (CPTDATH – Address FFD9h)

The codec port interface data register (high byte) contains the most significant byte of the 16-bit command or status data value used for secondary communication between the TAS1020A MCU and the codec device. This register is not used for general-purpose mode or AIC mode since these modes only support an 8-bit data value for secondary communication.

Bit	7	6	5	4	3	2	1	0
Mnemonic	D15	D14	D13	D12	D11	D10	D9	D8
Type	R/W	R/W	R/W	R/W	R/W	R/W	R/W	R/W
Default	0	0	0	0	0	0	0	0

BIT	MNEMONIC	NAME	DESCRIPTION
7:0	D(15:8)	Command/status data	The command/status data value is set by the MCU with the command data to be transmitted to the codec device for write transactions. The command/status data value is updated by hardware with the status data received from the codec device for read transactions.

#### A.5.4.9 Codec Port Interface Valid Time Slots Register (Low Byte) (CPTVSLL – Address FFD8h)

The codec port interface valid time slots register (low byte) contains the control bits used to specify which time slots in the audio frame contain valid data. This register is only used in the AC '97 modes of operation.

Bit	7	6	5	4	3	2	1	0
Mnemonic	VTSL8	VTSL9	VTSL10	VTSL11	VTSL12	—	—	—
Type	R/W	R/W	R/W	R/W	R/W	R	R	R
Default	0	0	0	0	0	0	0	0

BIT	MNEMONIC	NAME	DESCRIPTION
7:3	VTSL(8:12)	Valid time slot	The valid time slot bits are set to a 1 by the MCU to define which time slots in the audio frame contain valid data. The MCU must clear to a 0 the bits corresponding to time slots that do not contain valid data. Note that bits 7 to 3 of this register correspond to time slots 8 to 12.
2:0	—	Reserved	Reserved for future use

#### A.5.4.10 Codec Port Interface Valid Time Slots Register (High Byte) (CPTVSLH – Address FFD7h)

The codec port interface valid time slots register (high byte) contains the control bits used to specify which time slots in the audio frame contain valid data. In addition the valid frame, primary codec ready and secondary codec ready bits are contained in this register. This register is only used in the AC '97 modes of operation.

Bit	7	6	5	4	3	2	1	0
Mnemonic	VF	PCRDY	SCRDY	VTSL3	VTSL4	VTSL5	VTSL6	VTSL7
Type	R/W	R	R	R/W	R/W	R/W	R/W	R/W
Default	0	0	0	0	0	0	0	0

BIT	MNEMONIC	NAME	DESCRIPTION
7	VF	Valid frame	The valid frame bit is set to a 1 by the MCU to indicate that the current audio frame contains at least one time slot with valid data. The MCU must clear this bit to a 0 to indicate that the current audio frame does not contain any time slots with valid data.
6	PCRDY	Primary codec ready	The primary codec ready bit is updated by hardware each audio frame based on the value of bit 15 in time slot 0 of the incoming serial data from the primary codec. This bit is set to a 1 to indicate the primary codec is ready for operation.
5	SCRDY	Secondary codec ready	The secondary codec ready bit is updated by hardware each audio frame based on the value of bit 15 in time slot 0 of the incoming serial data from the secondary codec. This bit is set to a 1 to indicate the secondary codec is ready for operation. Note that this bit is only used if a secondary codec is connected to the TAS1020A device.
4:0	VTSL(3:7)	Valid time slot	The valid time slot bits are set to a 1 by the MCU to define which time slots in the audio frame contain valid data. The MCU must clear to a 0 the bits corresponding to time slots that do not contain valid data. Note that bits 4 to 0 of this register correspond to time slots 3 to 7.

#### A.5.4.11 Codec Port Receive Interface Configuration Register 2 (CPTRXCNF2 – Address FFD6h)

The codec port receive interface configuration register2 is only used in I<sup>2</sup>S Mode 5.

Bit	7	6	5	4	3	2	1	0
Mnemonic	–	–	BPTSL2	BPTSL1	BPTSL0	TSL2	TSL1	TSL0
Type	R	R	R/W	R/W	R/W	R/W	R/W	R/W
Default	0	0	0	0	0	0	0	0

BIT	MNEMONIC	NAME	DESCRIPTION
7:6	—	Reserved	Reserved for future use
5:3	BPTSL(2:0)	Data bits per time slot.	The data bits per time slot bits are set by the MCU to program the number of data bits per audio time slot. Note that this value is not used for the secondary communication address and data time slots. 000b = 8 data bits per time slot 001b = 16 data bits per time slot 010b = 18 data bits per time slot 011b = 20 data bits per time slot 100b = 24 data bits per time slot 101b = 32 data bits per time slot 110b = reserved 111b = reserved
2:0	TSL(2:0)	Time slot length	The time slot length bits are set by the MCU to program the number of serial clock (SCLK2) cycles for all time slots. 000b = 8 SCLK2 cycles per time slot 001b = 16 SCLK2 cycles per time slot 010b = 18 SCLK2 cycles per time slot 011b = 20 SCLK2 cycles per time slot 100b = 24 SCLK2 cycles per time slot 101b = 32 SCLK2 cycles per time slot 110b = reserved 111b = reserved



#### A.5.4.12 Codec Port Receive Interface Configuration Register 3 (CPTRXCNF3 – Address FFD5h)

The codec port receive interface configuration register3 is only used in I<sup>2</sup>S Mode 5.

Bit	7	6	5	4	3	2	1	0
Mnemonic	DDLY	TRSEN	CSCLKP	CSYNCP	CSYNCL	BYOR	CSCLKD	CSYNCD
Type	R/W	R/W	R/W	R/W	R/W	R/W	R/W	R/W
Default	0	0	1	1	0	0	0	0

BIT	MNEMONIC	NAME	DESCRIPTION
7	DDLY	Data delay	The data delay bit is set to 1 by the MCU to program a one SCLK2 cycle delay of the serial data output and input signals in reference to the leading edge of the LRCK2 signal. The MCU must clear this bit to a 0 for no delay between these signals.
6	TRSEN	3-state enable	The 3-state enable bit is set to a 1 by the MCU to program the hardware to set the serial data output signal to the high-impedance state for time slots during the audio frame that are not valid. The MCU must clear this bit to a 0 to program the hardware to use zero-padding for the serial data output signal for time slots during the audio frame that are not valid.
5	CSCLKP	CSCLK polarity	The CSCLKP polarity bit is used by the MCU to program the clock edge used for the codec port interface frame sync (LRCK2) output signal and codec port interface serial data input (CDAT1) signal. When this bit is set to a 1, the LRCK2 signal is generated with the negative edge of the codec port interface serial clock (SCLK2) signal. Also, when this bit is set a 1, the CDAT1 signal is sampled with the positive edge of the SCLK2 signal. When this bit is cleared to 0, the LRCK2 signal is generated with the positive edge of SCLK2 and the CDAT1 signal is sampled with the negative edge of the SCLK2 signal.
4	CSYNCP	CSYNC polarity	The CSYNCP polarity bit is set to a 1 by the MCU to program the polarity of the codec port interface frame sync (LRCK2) output signal to be active high. The MCU must clear this bit to a 0 to program the polarity of the LRCK2 output signal to be active low.
3	CSYNCL	CSYNC length	The CSYNCL polarity bit is set to a 1 by the MCU to program the length of the codec port interface frame sync (LRCK2) output signal to be the same number of SCLK2 cycles as time slot 0. The MCU must clear this bit to a 0 to program the length of the LRCK2 output signal to be one SCLK2 cycle.
2	BYOR	Byte order	The byte order bit is used by the MCU to program the byte order for the data moved by the DMA between the USB endpoint buffer and the codec port interface. When this bit is set to a 1, the byte order of each audio sample is reversed when the data is moved to/from the USB endpoint buffer. When this bit is cleared to a 0, the byte order of the each audio sample is unchanged.
1	CSCLKD	CSCLK direction	The SCLK2 direction bit is set to a 1 by the MCU to program the direction of the codec port interface serial clock (SCLK2) signal as an input of the TAS1020A device. The MCU must clear this bit to a 0 to program the direction of the CSCLK signal as an output from the TAS1020A device.
0	CSYNCD	CSYNC direction	The SCLK2 direction bit is set to a 1 by the MCU to program the direction of the codec port interface frame sync (LRCK2) signal as an input of the TAS1020A device. The MCU must clear this bit to a 0 to program the direction of the LRCK2 signal as an output from the TAS1020A device.

### A.5.4.13 Codec Port Receive Interface Configuration Register 4 (CPTRXCNF4 – Address FFD4h)

The codec port receive interface configuration register4 is only used in I<sup>2</sup>S Mode 5.

Bit	7	6	5	4	3	2	1	0
Mnemonic	–	–	–	–	–	DIVB22	DIVB21	DIVB20
Type	R	R	R	R	R	R/W	R/W	R/W
Default	0	0	0	0	0	0	0	0

BIT	MNEMONIC	NAME	DESCRIPTION
7:3	—	Reserved	Reserved for future use
2:0	DIVB2(2:0)	Divide by B2 value	The divide by B2 control bits are set by the MCU to program the divide ratio used to derive SCLK2 from MCLKO2. 000b = SCLK2 output disabled 001b = divide by 2 010b = divide by 3 011b = divide by 4 100b = divide by 5 101b = divide by 6 110b = divide by 7 111b = divide by 8

### A.5.5 P3 Mask Register

Mask register for P3 to enable the wake-up function for these pins when the device is in low-power mode.

#### A.5.5.1 P3 Mask Register (P3MSK–Address FFCAh)

Bit	7	6	5	4	3	2	1	0
Mnemonic	P3MSK7	P3MSK6	P3MSK5	P3MSK4	P3MSK3	P3MSK2	P3MSK1	P3MSK0
Type	R/W	R/W	R/W	R/W	R/W	R/W	R/W	R/W
Default	0	0	0	0	0	0	0	0

BIT	MNEMONIC	NAME	DESCRIPTION
7:0	P3MSK(7:0)		0 = Unmasked 1 = Masked

### A.5.6 I<sup>2</sup>C Interface Registers

This section describes the memory-mapped registers used for the I<sup>2</sup>C Interface control and operation. The I<sup>2</sup>C interface has a set of four registers. See Section 2.2.14 for the operation details of the I<sup>2</sup>C Interface.

#### A.5.6.1 I<sup>2</sup>C Interface Address Register (I2CADR – Address FFC3h)

The I<sup>2</sup>C interface address register contains the 7-bit I<sup>2</sup>C slave device address and the read/write transaction control bit.

Bit	7	6	5	4	3	2	1	0
Mnemonic	A6	A5	A4	A3	A2	A1	A0	RW
Type	R/W	R/W	R/W	R/W	R/W	R/W	R/W	R/W
Default	0	0	0	0	0	0	0	0

BIT	MNEMONIC	NAME	DESCRIPTION
7:1	A(6:0)	Address	The address bit values are set by the MCU to program the 7-bit I <sup>2</sup> C slave address of the device to be accessed. Each I <sup>2</sup> C slave device must have a unique address on the I <sup>2</sup> C bus. This address is used to identify the device on the bus to be accessed and is not the internal memory address to be accessed within the device.
0	RW	Read/write control	The read/write control bit value is set by the MCU to program the type of I <sup>2</sup> C transaction to be done. This bit must be set to a 1 by the MCU for a read transaction and cleared to a 0 by the MCU for a write transaction.

### A.5.6.2 I<sup>2</sup>C Interface Receive Data Register (I2CDATI – Address FFC2h)

The I<sup>2</sup>C interface receive data register contains the most recent data byte received from the slave device.

<b>Bit</b>	<b>7</b>	<b>6</b>	<b>5</b>	<b>4</b>	<b>3</b>	<b>2</b>	<b>1</b>	<b>0</b>
<b>Mnemonic</b>	<b>RXD7</b>	<b>RXD6</b>	<b>RXD5</b>	<b>RDXD4</b>	<b>RXD3</b>	<b>RXD2</b>	<b>RXD1</b>	<b>RXD0</b>
<b>Type</b>	<b>R</b>	<b>R</b>	<b>R</b>	<b>R</b>	<b>R</b>	<b>R</b>	<b>R</b>	<b>R</b>
<b>Default</b>	<b>0</b>	<b>0</b>	<b>0</b>	<b>0</b>	<b>0</b>	<b>0</b>	<b>0</b>	<b>0</b>

<b>BIT</b>	<b>MNEMONIC</b>	<b>NAME</b>	<b>DESCRIPTION</b>
7:0	RXD(7:0)	Receive data	The receive data byte value is updated by hardware for each data byte received from the I <sup>2</sup> C slave device.

### A.5.6.3 I<sup>2</sup>C Interface Transmit Data Register (I2CDATO – Address FFC1h)

The I<sup>2</sup>C interface transmit data register contains the next address or data byte to be transmitted to the slave device in accordance with the protocol. Note that for both read and write transactions, the internal register or memory address of the slave device being accessed must be transmitted to the slave device.

<b>Bit</b>	<b>7</b>	<b>6</b>	<b>5</b>	<b>4</b>	<b>3</b>	<b>2</b>	<b>1</b>	<b>0</b>
<b>Mnemonic</b>	<b>TXD7</b>	<b>TXD6</b>	<b>TXD5</b>	<b>TXD4</b>	<b>TXD3</b>	<b>TXD2</b>	<b>TXD1</b>	<b>TXD0</b>
<b>Type</b>	<b>W</b>	<b>W</b>	<b>W</b>	<b>W</b>	<b>W</b>	<b>W</b>	<b>W</b>	<b>W</b>
<b>Default</b>	<b>0</b>	<b>0</b>	<b>0</b>	<b>0</b>	<b>0</b>	<b>0</b>	<b>0</b>	<b>0</b>

<b>BIT</b>	<b>MNEMONIC</b>	<b>NAME</b>	<b>DESCRIPTION</b>
7:0	TXD(7:0)	Transmit data	The transmit data byte value is set by the MCU for each address or data byte to be transmitted to the I <sup>2</sup> C slave device.

#### A.5.6.4 I<sup>2</sup>C Interface Control and Status Register (I2CCTL – Address FFC0h)

The I<sup>2</sup>C interface control and status register contains various control and status bits used for the I<sup>2</sup>C interface operation.

Bit	7	6	5	4	3	2	1	0
Mnemonic	RXF	RXIE	ERR	FRQ	TXE	TXIE	STPRD	STPWR
Type	R	R/W	R/W	R/W	R	R/W	R/W	R/W
Default	0	0	0	0	0	0	0	0

BIT	MNEMONIC	NAME	DESCRIPTION
7	RXF	Receive data register full	The receive data register full bit is set to a 1 by hardware when a new data byte has been received into the receive data register from the slave device. This bit is read only and is cleared to a 0 by hardware when the MCU reads the new byte from the receive data register. Note that when the MCU writes to the interrupt vector register, the I <sup>2</sup> C receive data register full interrupt is cleared but this status bit is not cleared at that time.
6	RXIE	Receive interrupt enable	The receive interrupt enable bit is set to a 1 by the MCU to enable the I <sup>2</sup> C receive data register full interrupt.
5	ERR	Error condition	The error condition bit is set to a 1 by hardware when the slave device does not respond. This bit is read/write and can only be cleared by the MCU.
4	FRQ	Frequency select	The frequency select bit is used by the MCU to program the I <sup>2</sup> C serial clock (SCL) output signal frequency. A value of 0 sets the SCL frequency to 100 kHz and a value of 1 sets the SCL frequency to 400 kHz.
3	TXE	Transmit data register empty	The transmit data register empty bit is set to a 1 by hardware when the data byte in the transmit data register has been sent to the slave device. This bit is read only and is cleared to a 0 by hardware when a new data byte is written to the transmit data register by the MCU. Note that when the MCU writes to the interrupt vector register, the I <sup>2</sup> C transmit data register empty interrupt is cleared but this status bit is not cleared at that time.
2	TXIE	Transmit interrupt enable	The transmit interrupt enable bit is set to a 1 by the MCU to enable the I <sup>2</sup> C transmit data register empty interrupt.
1	STPRD	Stop – read transaction	The stop read transaction bit is set to a 1 by the MCU to enable the hardware to generate a stop condition on the I <sup>2</sup> C bus after the next data byte from the slave device is received into the receive data register. The MCU must clear this bit to a 0 after the read transaction has concluded.
0	STPWR	Stop – write transaction	The stop write transaction bit is set to a 1 by the MCU to enable the hardware to generate a stop condition on the I <sup>2</sup> C bus after the data byte in the transmit data register is sent to the slave device. The MCU must clear this bit to a 0 after the write transaction has concluded.

## A.5.7 Miscellaneous Registers

This section describes the memory-mapped registers used for the control and operation of miscellaneous functions in the TAS1020A device. The registers include the USB OUT endpoint interrupt register, the USB IN endpoint interrupt register, the interrupt vector register, the global control register, and the memory configuration register.

### A.5.7.1 USB OUT endpoint Interrupt Register (OEPINT – Address FFB4h)

The USB OUT endpoint interrupt register contains the interrupt pending status bits for the USB OUT endpoints. These bits do not apply to the USB isochronous endpoints. Also, these bits are read only by the MCU and are used for diagnostic purposes only.

Bit	7	6	5	4	3	2	1	0
Mnemonic	OEP17	OEP16	OEP15	OEP14	OEP13	OEP12	OEP11	OEP10
Type	R	R	R	R	R	R	R	R
Default	0	0	0	0	0	0	0	0

BIT	MNEMONIC	NAME	DESCRIPTION
7:0	OEP1(7:0)	OUT endpoint interrupt	The OUT endpoint interrupt status bit for a particular USB OUT endpoint is set to a 1 by the UBM when a successful completion of a transaction occurs to that OUT endpoint. When a bit is set, an interrupt to the MCU is generated and the corresponding interrupt vector results. The status bit is cleared when the MCU writes to the interrupt vector register. These bits do not apply to isochronous OUT endpoints.

### A.5.7.2 USB IN endpoint Interrupt Register (IEPINT – Address FFB3h)

The USB IN endpoint interrupt register contains the interrupt pending status bits for the USB IN endpoints. These bits do not apply to the USB isochronous endpoints. Also, these bits are read only by the MCU and are used for diagnostic purposes only.

Bit	7	6	5	4	3	2	1	0
Mnemonic	IEPI7	IEPI6	IEPI5	IEPI4	IEPI3	IEPI2	IEPI1	IEPI0
Type	R	R	R	R	R	R	R	R
Default	0	0	0	0	0	0	0	0

BIT	MNEMONIC	NAME	DESCRIPTION
7:0	IEPI(7:0)	IN endpoint interrupt	The IN endpoint interrupt status bit for a particular USB IN endpoint is set to a 1 by the UBM when a successful completion of a transaction occurs to that IN endpoint. When a bit is set, an interrupt to the MCU is generated and the corresponding interrupt vector results. The status bit is cleared when the MCU writes to the interrupt vector register. These bits do not apply to isochronous IN endpoints.

### A.5.7.3 Interrupt Vector Register (VECINT – Address FFB2H)

The interrupt vector register contains a 6-bit vector value that identifies the interrupt source for the INT0 input to the MCU. All of the TAS1020A internal interrupt sources and the external interrupt input to the device are ORed together to generate the internal INT0 signal to the MCU. When there is not an interrupt pending, the interrupt vector value is set to 24h. To clear any interrupt and update the interrupt vector value to the next pending interrupt, the MCU should simply write any value to this register. The interrupt priority is fixed in order, ranging from vector value 1Fh with the highest priority to vector value 00h with the lowest priority. An exception to this priority is the control endpoint EP0 which has top priority.

<b>Bit</b>	<b>7</b>	<b>6</b>	<b>5</b>	<b>4</b>	<b>3</b>	<b>2</b>	<b>1</b>	<b>0</b>
<b>Mnemonic</b>	—	—	<b>IVEC5</b>	<b>IVEC4</b>	<b>IVEC3</b>	<b>IVEC2</b>	<b>IVEC1</b>	<b>IVEC0</b>
<b>Type</b>	<b>R</b>	<b>R</b>	<b>R</b>	<b>R</b>	<b>R</b>	<b>R</b>	<b>R</b>	<b>R</b>
<b>Default</b>	<b>0</b>	<b>0</b>	<b>0</b>	<b>0</b>	<b>0</b>	<b>0</b>	<b>0</b>	<b>0</b>

<b>BIT</b>	<b>MNEMONIC</b>	<b>NAME</b>	<b>DESCRIPTION</b>	
7	—	Reserved	Reserved for future use	
6	—	Reserved	Reserved for future use	
5:0	IVEC(5:0)	Interrupt vector	00h = USB OUT endpoint 0 01h = USB OUT endpoint 1 02h = USB OUT endpoint 2 03h = USB OUT endpoint 3 04h = USB OUT endpoint 4 05h = USB OUT endpoint 5 06h = USB OUT endpoint 6 07h = USB OUT endpoint 7 08h = USB IN endpoint 0 09h = USB IN endpoint 1 0Ah = USB IN endpoint 2 0Bh = USB IN endpoint 3 0Ch = USB IN endpoint 4 0Dh = USB IN endpoint 5 0Eh = USB IN endpoint 6 0Fh = USB IN endpoint 7	10h = USB setup stage transaction over-write 11h = Reserved 12h = USB setup stage transaction 13h = USB pseudo start-of-frame 14h = USB start-of-frame 15h = USB function resume 16h = USB function suspend 17h = USB function reset 18h = C-port receive data register full 19h = C-port transmit data register empty 1Ah = Reserved 1Bh = Reserved 1Ch = I <sup>2</sup> C receive data register full 1Dh = I <sup>2</sup> C transmit data register empty 1Eh = Reserved 1Fh = External interrupt input
			20h = DMA Ch.0 interrupt 21h = DMA Ch.1 interrupt 22h - 23h = Reserved	24h = No interrupt pending 25h – 3Fh = Reserved

#### A.5.7.4 Global Control Register (GLOBCTL – Address FFB1h)

The global control register contains various global control bits for the TAS1020A device.

Bit	7	6	5	4	3	2	1	0
Mnemonic	MCUCLK	XINTEN	P1PUDIS	VREN	RESET	LPWR	P3PUDIS	CPTEN
Type	R/W	R/W	R/W	R/W	R/W	R/W	R/W	R/W
Default	0	0	0	0	0	0	0	0

BIT	MNEMONIC	NAME	DESCRIPTION
7	MCUCLK	MCU clock select	The MCU clock select bit is used by the MCU to program the clock frequency to be used for the MCU operation. 0b = 12 MHz and 1b = 24 MHz POR (Power On Reset) value is 0 (12 MHz). Setting this bit to 1 will change MCU clock frequency to 24 MHz. But, once set, this bit can only be cleared by master reset.
6	XINTEN	External interrupt enable	The external interrupt enable bit is set to a 1 by the MCU to enable the use of the external interrupt input to the TAS1020A device.
5	P1PUDIS	Pullup resistor disable	If set to 1, disables on-chip pullup resistors on P1 GPIO pins.
4	VREN	VREN	Memory-mapped GPIO pin.
3	RESET	RESET	Memory-mapped GPIO pin.
2	LPWR	Low power mode	The low power mode disable bit is used by the MCU to put the TAS1020A into a semi-low power state. When this bit is cleared to a 0, all USB functional blocks are powered down. For normal operation, the MCU must set this bit to a 1.
1	P3PUDIS	Pullup resistor disable	If set to 1, disables on-chip pullup resistors on P3 GPIO pins.
0	CPTEN	Codec port enable	The codec port enable bit is set to a 1 by the MCU to enable the operation of the codec port interface. Note that the codec port interface configuration registers must be fully programmed before this bit is set by the MCU.

#### A.5.7.5 Memory Configuration Register (MEMCFG – Address FFB0h)

The memory configuration register contains various bits pertaining to the memory configuration of the TAS1020A device.

Bit	7	6	5	4	3	2	1	0
Mnemonic	MEMTYP	CODESZ1	CODESZ0	REV3	REV2	REV1	REV0	SDW
Type	R	R	R	R	R	R	R	R/W
Default	1	0	1	0	0	0	1	0

BIT	MNEMONIC	NAME	DESCRIPTION
7	MEMTYP	Code memory type	The code memory type bit identifies if the type of memory used for the application program code space is ROM or RAM. For the TAS1020A, an 8K byte RAM is used and this bit is tied to 1.
6:5	CODESZ(1:0)	Code space size	The code space size bits identify the size of the application program code memory space. For the TAS1020A, an 8K byte RAM is used and these bits are tied to 01b. 00b = 4K bytes, 01b = 8K bytes, 10b = 16K bytes, 11b = 32K bytes
4:1	REV(3:0)	IC revision	The IC revision bits identify the revision of the IC. 0000b = Rev. -, 0001b = Rev. A, ..., 1111b = Rev. F
0	SDW	Shadow the boot ROM	The shadow the boot ROM bit is set to a 1 by the MCU to switch the MCU memory configuration from boot loader mode to normal operating mode. This must occur after completion of the download of the application program code by the boot ROM. Reference SDW protection bit in USBCTL register.





## Appendix B Mechanical Data

PFB (S-PQFP-G48)

PLASTIC QUAD FLATPACK

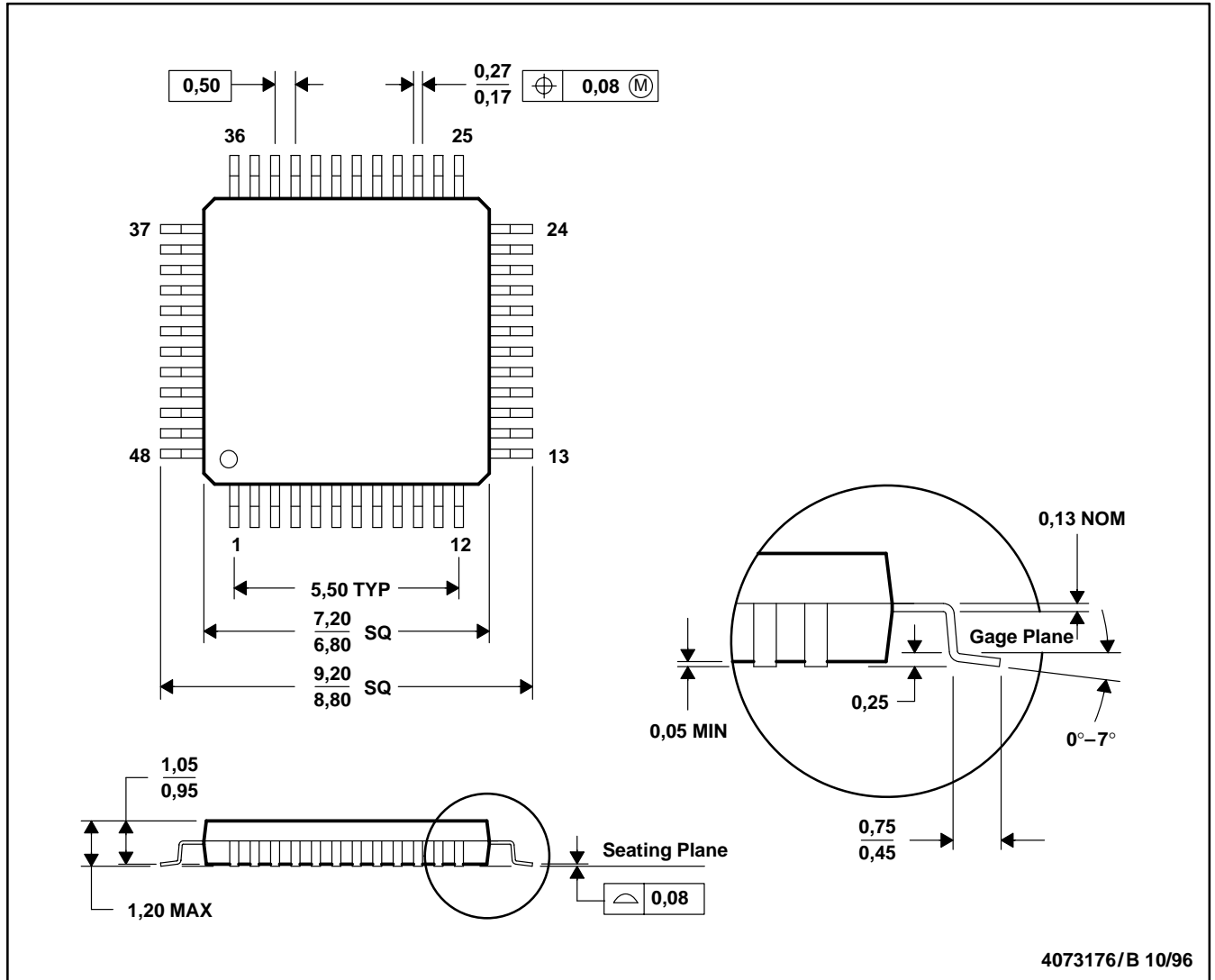

- NOTES:
- A. All linear dimensions are in millimeters.
  - B. This drawing is subject to change without notice.
  - C. Falls within JEDEC MS-026

