

Dual 150mA CMOS LDO With Select Mode™ Operation, Shutdown And RESET Output

FEATURES

- Extremely Low Supply Current for Longer Battery Life
- Select Mode™ Operation: Selectable Output Voltages for High Design Flexibility
- Very Low Dropout Voltage
- 10µsec (Typ.) Wake-Up Time from SHDN
- Maximum 150mA Output Current per Output
- High Output Voltage Accuracy
- Power-Saving Shutdown Mode
- RESET Output Can Be Used as a Low Battery Detector, or Processor Reset Generator
- Over-Current Protection and Over-Temperature Shutdown
- Space-Saving 8-Pin MSOP Package

APPLICATIONS

- Load Partitioning
- Battery Operated Systems
- Portable Computers
- Medical Instruments
- Instrumentation
- Cellular / GSM / PHS Phones
- Linear Post-Regulator for SMPS
- Pagers

GENERAL DESCRIPTION

The TC1306 combines two CMOS Low Dropout Regulators and a Microprocessor Monitor in a space-saving 8-Pin MSOP package. Designed specifically for battery-operated systems, total supply current for the device is typically 120µA at full load; 20 to 60 times lower than in bipolar regulators.

The TC1306 features selectable output voltages for higher design flexibility. The dual-state SELECT input pin allows the user to select V_{OUT2} from 2 different values (2.8V and 3.0V). V_{OUT1} supplies a fixed 1.8V voltage.

An active low RESET is asserted when the output voltage V_{OUT2} falls below the 2.63V reset voltage threshold. The RESET output remains low for 300msec (typical) after V_{OUT2} rises above reset threshold. When the shutdown control (SHDN1) is low, the regulator output voltage V_{OUT1} falls to zero and RESET output remains valid. When the shutdown control (SHDN2) is low, the regulator output voltage V_{OUT2} falls to zero and RESET output is low.

Other key features for the device include ultra low-noise operation, fast response to step changes in load, and very low dropout voltage (typically 125mV at full load). The device also incorporates both over-temperature and over-current protection.

Each regulator is stable with an output capacitor of only 1µF and has a maximum output current of 150mA.

ORDERING INFORMATION

Part Number	Package	Junction Temp. Range
TC1306R-BDVUA	8-Pin MSOP	- 40°C to +125°C

NOTE: The "R" denotes the suffix for the 2.63V RESET threshold

Available Output Voltages:

B indicates $V_{out1} = 1.8V$ (fixed)
 D indicates $V_{out2} = 2.8V, 3.0V$ (selectable)

Other output voltages are available. Please contact Microchip Technology Inc. for details.

PIN CONFIGURATION

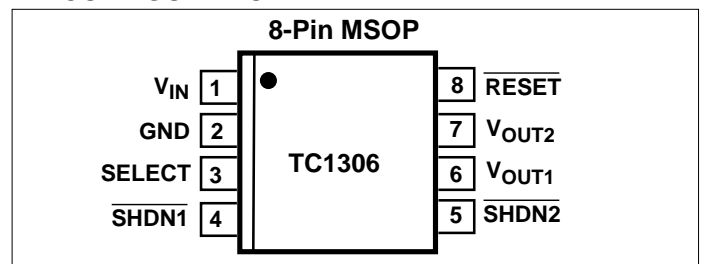

TYPICAL APPLICATION

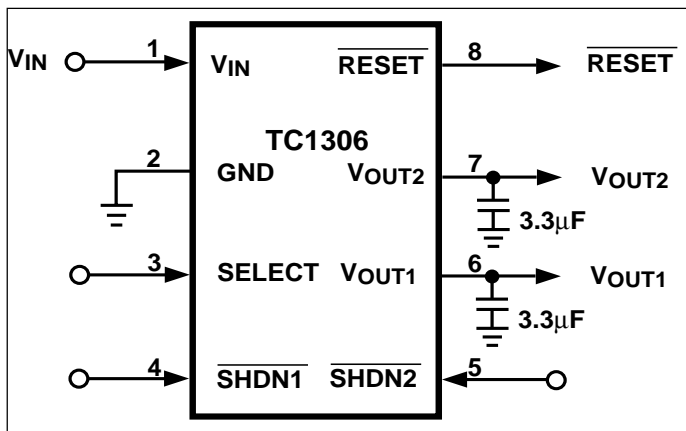

Dual 150mA CMOS LDO With Select Mode™ Operation, Shutdown and RESET Output

TC1306

ABSOLUTE MAXIMUM RATINGS*

Input Voltage	6.5V
Output Voltage	(– 0.3) to (V _{IN} + 0.3)
Power Dissipation	Internally Limited (Note 7)
Operating Temperature	– 40°C < T _J < 125°C
Storage Temperature	– 65°C to +150°C
Maximum Voltage On Any Pin	V _{IN} + 0.3V to – 0.3V

*Stresses beyond those listed under "Absolute Maximum Ratings" may cause permanent damage to the device. These are stress ratings only, and functional operation of the device at these or any other conditions beyond those indicated in the operational sections of the specifications is not implied. Exposure to absolute maximum rating conditions for extended periods may affect device reliability.

ELECTRICAL CHARACTERISTICS: [Output 1 + Output 2] V_{IN} = V_R + 1V, I_L = 100μA, C_L = 3.3μF, $\overline{\text{SHDN1}} > V_{IH}$, $\overline{\text{SHDN2}} > V_{IH}$, T_A = 25°C, unless otherwise noted. **Boldface** type specifications apply for junction temperatures of – 40°C to +125°C.

Symbol	Parameter	Test Conditions	Min	Typ	Max	Units
V _{IN}	Input Operating Voltage	Note 1	2.7	—	6.0	V
I _{OUTMAX}	Maximum Output Current		150	—	—	mA
V _{OUT}	Output Voltage	Note 2	V_R – 2.5%	V _R ±0.5%	V_R + 2.5%	V
TCV _{OUT}	V _{OUT} Temperature Coefficient	Note 3	—	20 40	—	ppm/°C
ΔV _{OUT} /ΔV _{IN}	Line Regulation	(V _R + 1V) ≤ V _{IN} ≤ 6V	—	0.05	0.35	%
ΔV _{OUT} /V _{OUT}	Load Regulation	I _L = 0.1mA to I _{OUTMAX} Note 4	—	0.3	2	%
V _{IN} – V _{OUT}	Dropout Voltage	I _L = 100μA I _L = 50mA I _L = 100mA I _L = 150mA Note 5	—	2 45 85 125	— 120 240 360	mV
I _{IN}	Supply Current	$\overline{\text{SHDN1}}, \overline{\text{SHDN2}} = V_{IH}$, I _L = 0	—	120	200	μA
I _{INSD}	Shutdown Supply Current	$\overline{\text{SHDN1}}, \overline{\text{SHDN2}} = 0V$	—	0.05	0.5	μA
PSRR	Power Supply Rejection Ratio	F _{RE} ≤ 120Hz	—	55	—	dB
I _{OUTSC}	Output Short Circuit Current	V _{OUT} = 0V	—	450	—	mA
ΔV _{OUT} /ΔP _D	Thermal Regulation	Notes 6, 7	—	0.04	—	V/W
t _{WK}	Wake Up Time (from Shutdown Mode)	V _{IN} = 5V C _{IN} = 1μF, C _{OUT} = 4.7μF I _L = 30mA, (See Fig. 1)	—	10	—	μsec
t _S	Settling Time (from Shutdown Mode)	V _{IN} = 5V C _{IN} = 1μF, C _{OUT} = 4.7μF I _L = 30mA, (See Fig. 1)	—	40	—	μsec
T _{SD}	Thermal Shutdown Die Temperature		—	160	—	°C
ΔT _{SD}	Thermal Shutdown Hysteresis		—	15	—	°C
eN	Output Noise	F = 10kHz	—	200	—	nV/√Hz

SHDN Input

V _{IH}	$\overline{\text{SHDN}}$ Input High Threshold	V _{IN} = 2.7V to 6.0V	65	—	—	%V _{IN}
V _{IL}	$\overline{\text{SHDN}}$ Input Low Threshold	V _{IN} = 2.7V to 6.0V	—	—	15	%V _{IN}

SELECT Input

V _{SELH}	SELECT Input High Threshold	V _{IN} = 2.7V to 6.0V	65	—	—	%V _{IN}
V _{SELL}	SELECT Input Low Threshold	V _{IN} = 2.7V to 6.0V	—	—	15	%V _{IN}

Dual 150mA CMOS LDO With Select Mode™ Operation, Shutdown and RESET Output

TC1306

ELECTRICAL CHARACTERISTICS: $V_{IN} = V_R + 1V$, $I_L = 100\mu A$, $C_L = 3.3\mu F$, $SHDN1 > V_{IH}$, $SHDN2 > V_{IH}$, $T_A = 25^\circ C$, unless otherwise noted. **Boldface** type specifications apply for junction temperatures of $-40^\circ C$ to $+125^\circ C$.

Symbol	Parameter	Test Conditions	Min	Typ	Max	Units
RESET Output						
$V_{MIN,IN}$	Minimum V_{IN} Operating Voltage	$T_A = 0^\circ C$ to $+70^\circ C$ $T_A = -40^\circ C$ to $+125^\circ C$	1.0 1.2	—	6.0 6.0	V
V_{TH}	Reset Threshold	$T_A = +25^\circ C$ $T_A = -40^\circ C$ to $+125^\circ C$	2.59 2.55	2.63 —	2.66 2.70	V
	Reset Threshold Tempco		—	30	—	ppm/ $^\circ C$
	V_{OUT2} to Reset Delay	$V_{OUT2} = V_{TH}$ to $(V_{TH} - 100mV)$	—	100	—	μsec
	Reset Active Timeout Period		140	300	560	msec
V_{OL}	RESET Output Voltage Low	$V_{OUT2} = V_{TH}$ min, $I_{SINK} = 1.2mA$ $V_{OUT2} = V_{TH}$ min, $I_{SINK} = 3.2mA$ $V_{OUT2} > 1.0V$, $I_{SINK} = 50\mu A$	— — —	— — —	0.3 0.4 0.3	V
V_{OH}	RESET Output Voltage High	$V_{OUT2} > V_{TH}$ max, $I_{SOURCE} = 500\mu A$ $V_{OUT2} > V_{TH}$ max, $I_{SOURCE} = 800\mu A$	$0.8 V_{OUT2}$ $V_{OUT2} - 1.5$	— —	— —	V

- NOTES:**
- The minimum V_{IN} has to meet two conditions: $V_{IN} \geq 2.7V$ and $V_{IN} \geq V_R + V_{DROPOUT}$
 - V_R is the regulator output voltage setting. For example: $V_R = 2.8V$, $3.0V$.
 - $TCV_{OUT} = \frac{(V_{OUTMAX} - V_{OUTMIN}) \times 10^6}{V_{OUT} \times \Delta T}$
 - Regulation is measured at a constant junction temperature using low duty cycle pulse testing. Load regulation is tested over a load range from 0.1mA to the maximum specified output current. Changes in output voltage due to heating effects are covered by the thermal regulation specification.
 - Dropout voltage is defined as the input to output differential at which the output voltage drops 2% below its nominal value at a 1V differential.
 - Thermal Regulation is defined as the change in output voltage at a time, t, after a change in power dissipation is applied, excluding load or line regulation effects. Specifications are for a current pulse equal to I_{LMAX} at $V_{IN} = 6V$ for $t = 10msec$.
 - The maximum allowable power dissipation is a function of ambient temperature, the maximum allowable junction temperature and the thermal resistance from junction-to-air (i.e. T_A , T_J , θ_{JA}). Please see **Thermal Considerations** section of this data sheet for more details.

PIN DESCRIPTION

Pin No. (8-Pin MSOP)	Symbol	Description
1	V_{IN}	Power supply input.
2	GND	Ground terminal.
3	SELECT	SELECT control input for setting V_{OUT2} . SELECT=Low for $V_{OUT2} = 2.8V$, SELECT=High for $V_{OUT2} = 3.0V$
4	SHDN1	Shutdown control input for V_{OUT1} . Regulator 1 is fully enabled when a logic high is applied to this input. Regulator 1 enters shutdown when a logic low is applied to this input. During shutdown, regulator output voltage falls to zero, RESET output remains valid.
5	SHDN2	Shutdown control input for V_{OUT2} . Regulator 2 is fully enabled when a logic high is applied to this input. Regulator 2 enters shutdown when a logic low is applied to this input. During shutdown, regulator output voltage falls to zero, and RESET output is low.
6	V_{OUT1}	Regulated voltage output 1.
7	V_{OUT2}	Regulated voltage output 2.
8	RESET	RESET Output. RESET=Low when V_{OUT2} is below the Reset Threshold Voltage. RESET=High when V_{OUT2} is above the Reset Threshold Voltage.

Dual 150mA CMOS LDO With Select Mode™ Operation, Shutdown and RESET Output

TC1306

DETAILED DESCRIPTION

The TC1306 is a precision fixed output voltage regulator that contains two fully independent 150mA outputs. The device also features separate shutdown modes for low-power operation. The Select Mode™ operation allows the user to select V_{OUT2} from two different values (2.8V, 3.0V), therefore providing high design flexibility. V_{OUT1} supplies a fixed 1.8V output voltage. The CMOS construction of the TC1306 results in a very low supply current, which does not increase with load changes. In addition, V_{OUT} remains stable and within regulation at no load currents.

The TC1306 also features an integrated microprocessor supervisor that monitors the V_{OUT2} output. The active low RESET signal is asserted when the voltage of V_{OUT2} falls below the reset voltage threshold (2.63V). The RESET output remains low for 300msec (typical) after V_{OUT2} rises above the reset threshold. The RESET output of the TC1306 is optimized to reject fast transient glitches on the monitored output line.

APPLICATION INFORMATION

Input and Output Capacitor

The TC1306 is stable with a wide range of capacitor values and types. A capacitor with a minimum value of 1 μ F from V_{OUT} to Ground is required. The output capacitor should have an effective series resistance (ESR) of 0.1 Ω to 10 Ω for a 1 μ F capacitor and 0.01 Ω to 10 Ω for a 10 μ F capacitor. A 1 μ F capacitor should be connected from the V_{IN} to GND if there is more than 10 inches of wire below the regulator and the AC filter capacitor, or if a battery is used as the power source. Aluminum electrolytic or tantalum capacitor types can be used. Since many aluminum electrolytic capacitors freeze at approximately -30°C , solid tantalums are recommended for applications operating below -20°C . When operating from sources other than batteries, supply-noise rejection and transient response can be improved by increasing the value of the input and output capacitors and employing passive filtering techniques.

Shutdown Mode

Applying a logic high to each of the shutdown pins turns on the corresponding output. Each regulator enters shutdown mode when a logic low is applied to the corresponding input. During shutdown mode, output voltage falls to zero, and regulator supply current is reduced to 0.5 μ A (max). If shutdown mode is not necessary, the pins should be connected to the V_{IN} .

Select Mode™ Operation

The Select Mode™ operation is a dual-state input that allows the user to select V_{OUT2} from two different values. By applying a logic low to the SELECT pin, V_{OUT2} is set to supply a 2.8V output voltage. A logic high signal at the SELECT pin sets V_{OUT2} to 3.0V. This output voltage functionality provides high design flexibility and minimizes cost associated with inventory, time-to-market and new device qualifications.

Turn On Response

The turn on response is defined as two separate response categories, **Wake-Up Time (t_{WK})** and **Settling Time (t_s)**.

The TC1306 has a fast Wake Up Time (10 μ sec typical) when released from shutdown. See Figure 2 for the **Wake Up Time** designated as t_{WK} . The **Wake-Up Time** is defined as the time it takes for the output to rise to 2% of the V_{OUT} value after being released from shutdown.

The total turn on response is defined as the **Settling Time (t_s)**, see Figure 2. **Settling Time** (inclusive with t_{WK}) is defined as the condition when the output is within 2% of its fully enabled value (40 μ sec typical) when released from shutdown. The settling time of the output voltage is dependent on load conditions and output capacitance on V_{OUT} (RC response).

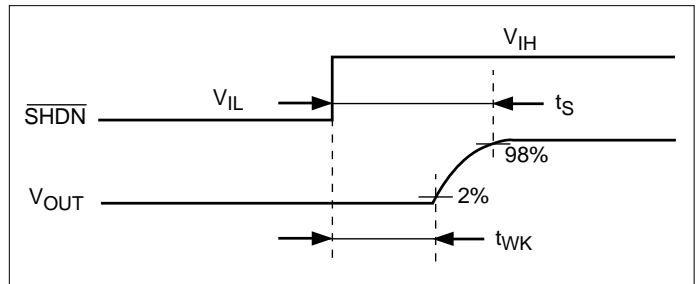

Figure 1: Wake-Up Response Time

Dual 150mA CMOS LDO With Select Mode™ Operation, Shutdown and RESET Output

TC1306

Thermal Considerations

Thermal Shutdown

Integrated thermal protection circuitry shuts the regulator off when die temperature exceeds 160°C. The regulator remains off until the die temperature drops to approximately 145°C.

Thermal shutdown is intended to protect the device under accidental overload conditions. Thermal Shutdown may not protect the LDO while operating above junction temperatures of 125°C continuously. Sufficient thermal evaluation of the design needs to be conducted to ensure that the junction temperature does not exceed 125°C.

Power Dissipation

The amount of power the regulator dissipates is primarily a function of input and output voltage, and output current. The following equation is used to calculate worst case *actual* power dissipation:

$$P_D \approx (V_{INMAX} - V_{OUT1MIN})I_{LOAD1MAX} + (V_{INMAX} - V_{OUT2MIN})I_{LOAD2MAX}$$

Where: P_D = worst case actual power dissipation
 V_{INMAX} = maximum voltage on V_{IN}
 $V_{OUT1MIN}$ = minimum regulator output voltage 1
 $I_{LOAD1MAX}$ = maximum output (load) current 1
 $V_{OUT2MIN}$ = minimum regulator output voltage 2
 $I_{LOAD2MAX}$ = maximum output (load) current 2

Equation 1.

The maximum allowable power dissipation (Equation 2) is a function of the maximum ambient temperature (T_{AMAX}), the maximum allowable die temperature (125°C), and the thermal resistance from junction-to-air (θ_{JA}). The MSOP-8 package has a θ_{JA} of approximately 200°C/W; when mounted on a four layer FR4 dielectric copper clad PC board.

$$P_{DMAX} = \frac{(T_{JMAX} - T_{AMAX})}{\theta_{JA}}$$

Where all terms are previously defined.

Equation 2.

Equation 1 can be used in conjunction with Equation 2 to ensure regulator thermal operation is within limits. For example:

GIVEN:

$$\begin{aligned} V_{INMAX} &= 3.8V \pm 5\% \\ V_{OUT1MIN} &= 1.8V \pm 2.5\% \\ V_{OUT2MIN} &= 3.0V \pm 2.5\% \\ I_{LOAD1MAX} &= 60mA \\ I_{LOAD2MAX} &= 120mA \\ T_{JMAX} &= 125^\circ C \\ T_{AMAX} &= 55^\circ C \\ \theta_{JA} &= 200^\circ C/W \end{aligned}$$

FIND:

1) Actual power dissipation:

$$\begin{aligned} P_D &\approx [(V_{INMAX} - V_{OUT1MIN}) \times I_{LOAD1MAX} \\ &+ [(V_{INMAX} - V_{OUT2MIN}) \times I_{LOAD2MAX} \\ &[(3.8 \times 1.05) - (1.8 \times .975)] \times 60 \times 10^{-3} \\ &+ [(3.8 \times 1.05) - (3.0 \times .975)] \times 120 \times 10^{-3} \\ &= \underline{262mW} \end{aligned}$$

2) Maximum allowable power dissipation:

$$\begin{aligned} P_D &\approx \frac{(T_{JMAX} - T_{AMAX})}{\theta_{JA}} \\ &= \frac{(125 - 55)}{200} \\ &= \underline{350mW} \end{aligned}$$

In this example, the TC1306 dissipates a maximum of only 262mW; below the allowable limit of 350mW. In a similar manner, Equation 1 and Equation 2 can be used to calculate maximum current and/or input voltage limits. For example, the maximum allowable V_{IN} is found by substituting the maximum allowable power dissipation of 350mW into Equation 1, from which $V_{INMAX} = 4.5V$.

Layout Considerations

The primary path of heat conduction out of the package is via the package leads. Therefore, layouts having a ground plane, wide traces at the pads, and wide power supply bus lines combine to lower θ_{JA} and, therefore, increase the maximum allowable power dissipation limit.

Dual 150mA CMOS LDO With Select Mode™ Operation, Shutdown and RESET Output

TC1306

TYPICAL CHARACTERISTICS

The graphs and tables provided following this note are statistical summary based on a limited number of samples and are provided for informational purposes only. The performance characteristics listed herein are not tested or guaranteed. In some graphs or tables, the data presented may be outside the specified operating range (e.g., outside specified power supply range) and therefore outside the warranted range.

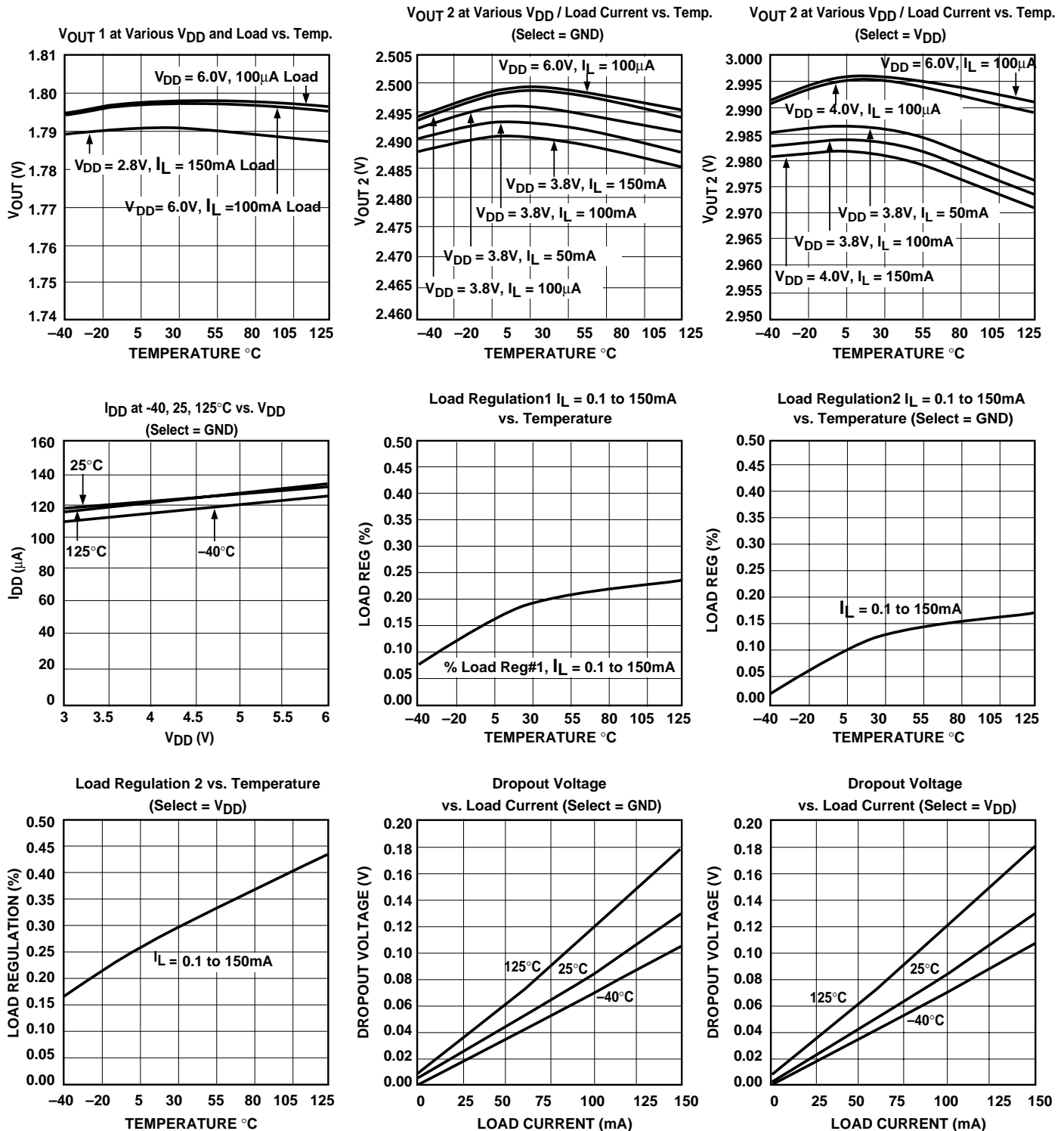

Dual 150mA CMOS LDO With Select Mode™ Operation, Shutdown and RESET Output

TC1306

TYPICAL CHARACTERISTICS (CONT)

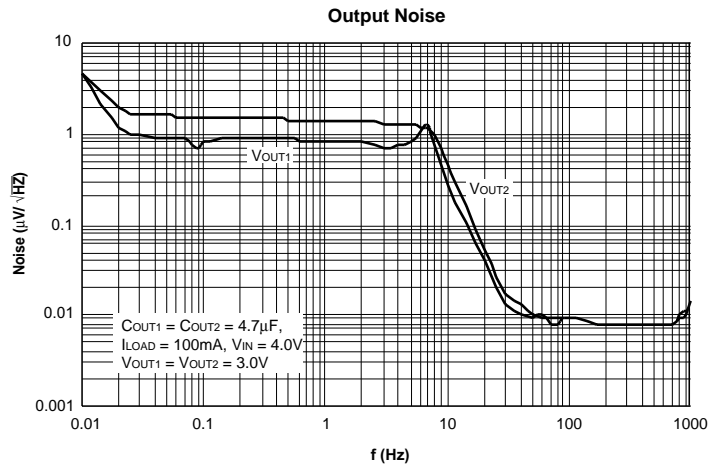
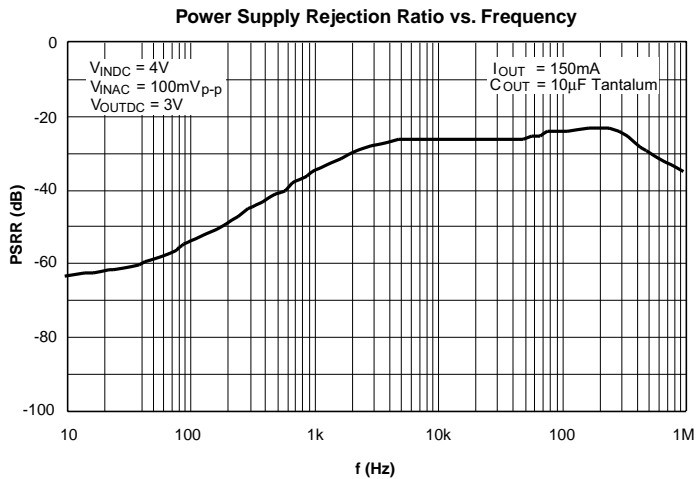
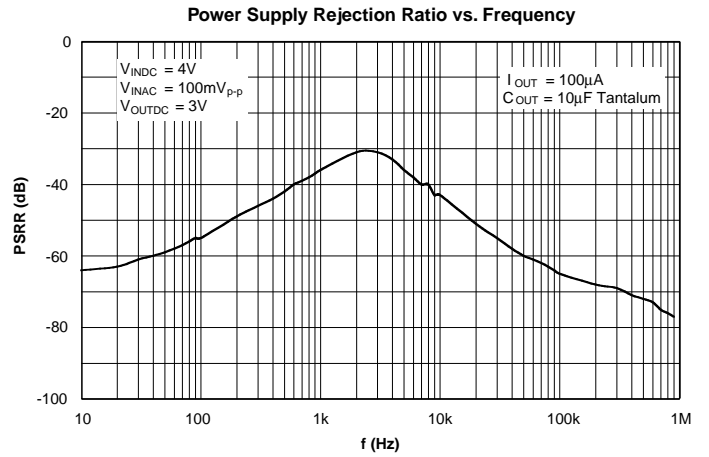
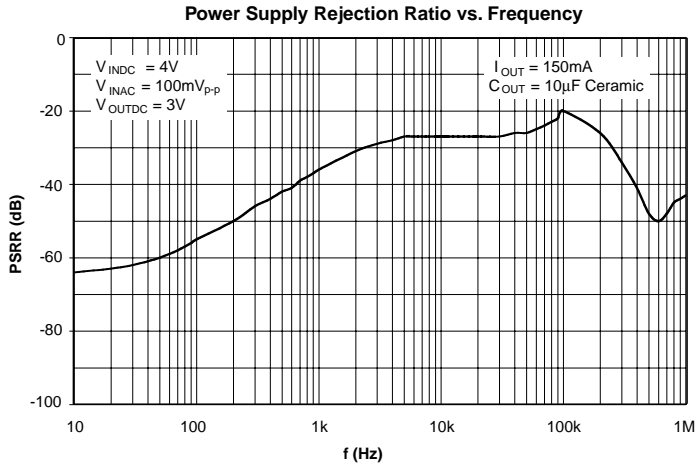

Dual 150mA CMOS LDO With Select Mode™ Operation, Shutdown and $\overline{\text{RESET}}$ Output

TC1306

TYPICAL CHARACTERISTICS (CONT)

Shutdown Response

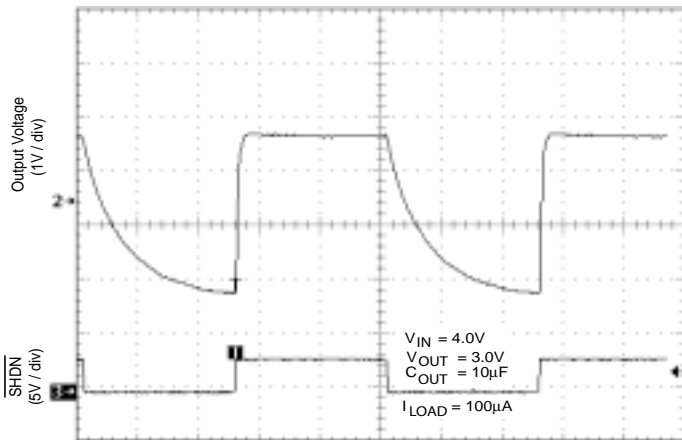

Time (200ms / div)

Thermal Shutdown Response

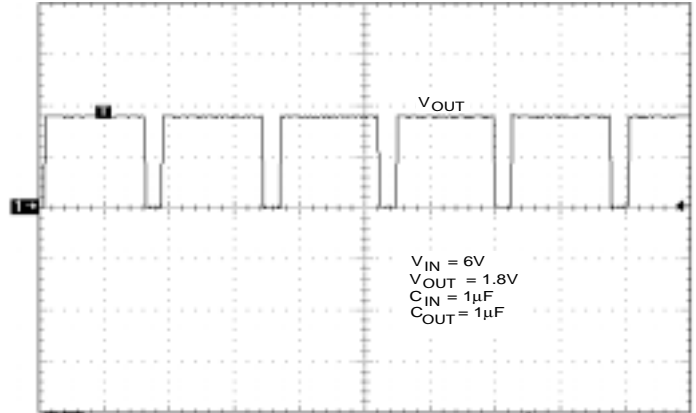

Time (500ms / div)

Thermal Shutdown Response

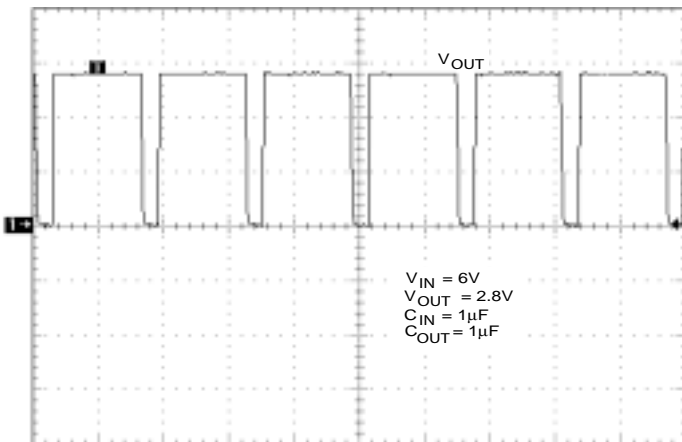

Time (500ms / div)

Thermal Shutdown Response

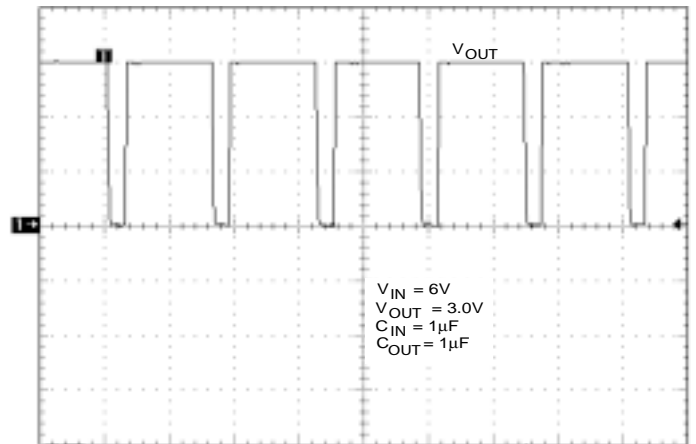

Time (500ms / div)

Line Transient Response

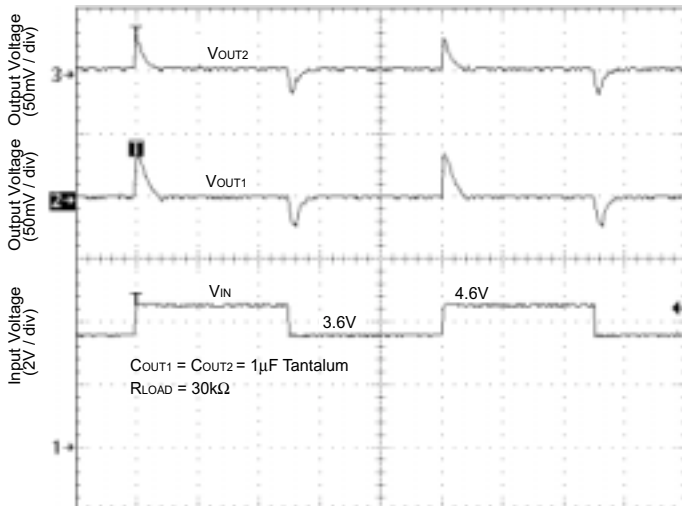

Line Transient Response

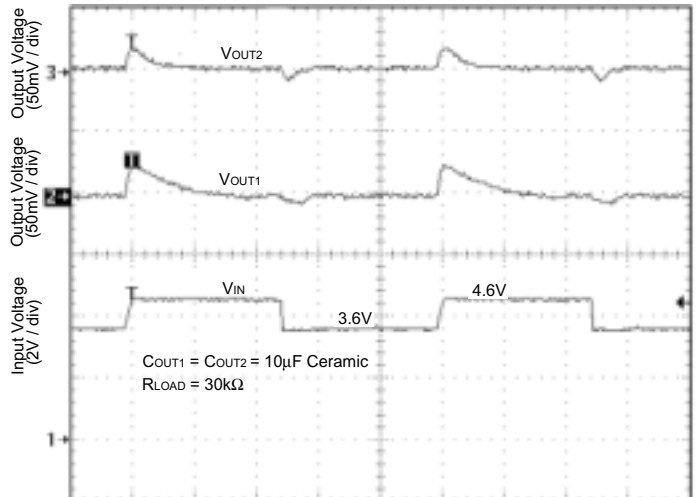

Dual 150mA CMOS LDO With Select Mode™ Operation, Shutdown and $\overline{\text{RESET}}$ Output

TC1306

TYPICAL CHARACTERISTICS (CONT)

Load Transient Response

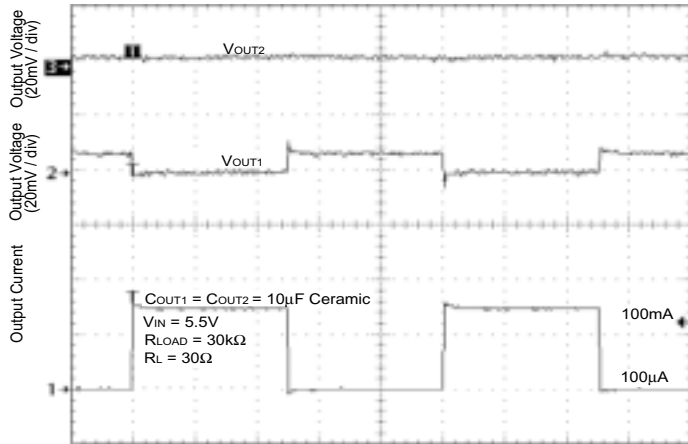

Load Transient Response

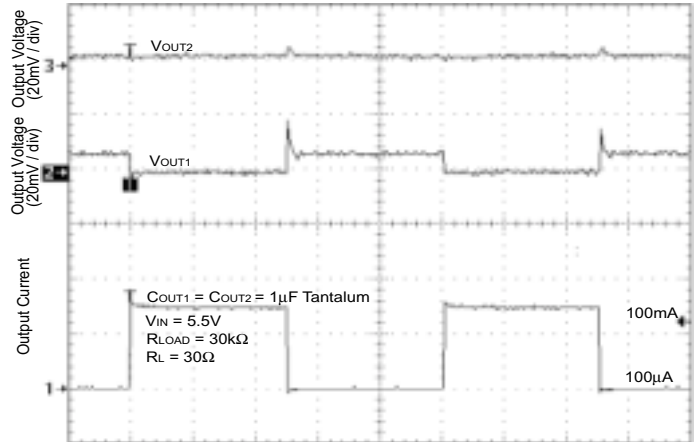

Load Transient Response

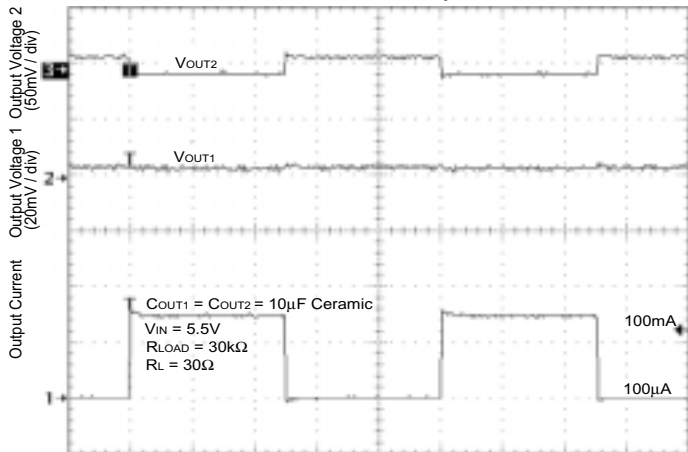

Load Transient Response

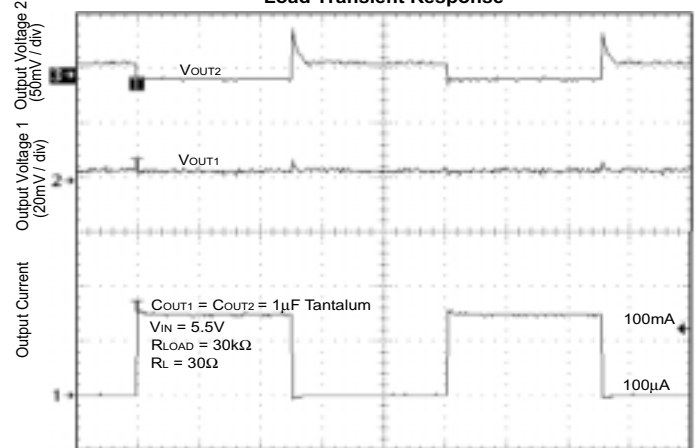

Wake-Up Response

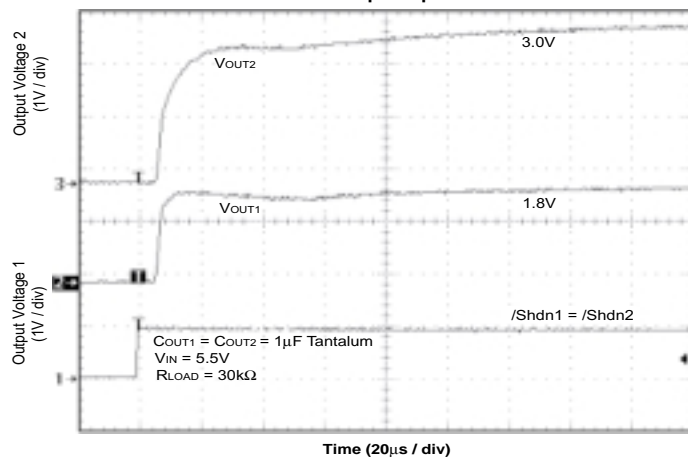

Dual 150mA CMOS LDO With Select Mode™ Operation, Shutdown and RESET Output

TC1306

TAPE AND REEL DIAGRAMS

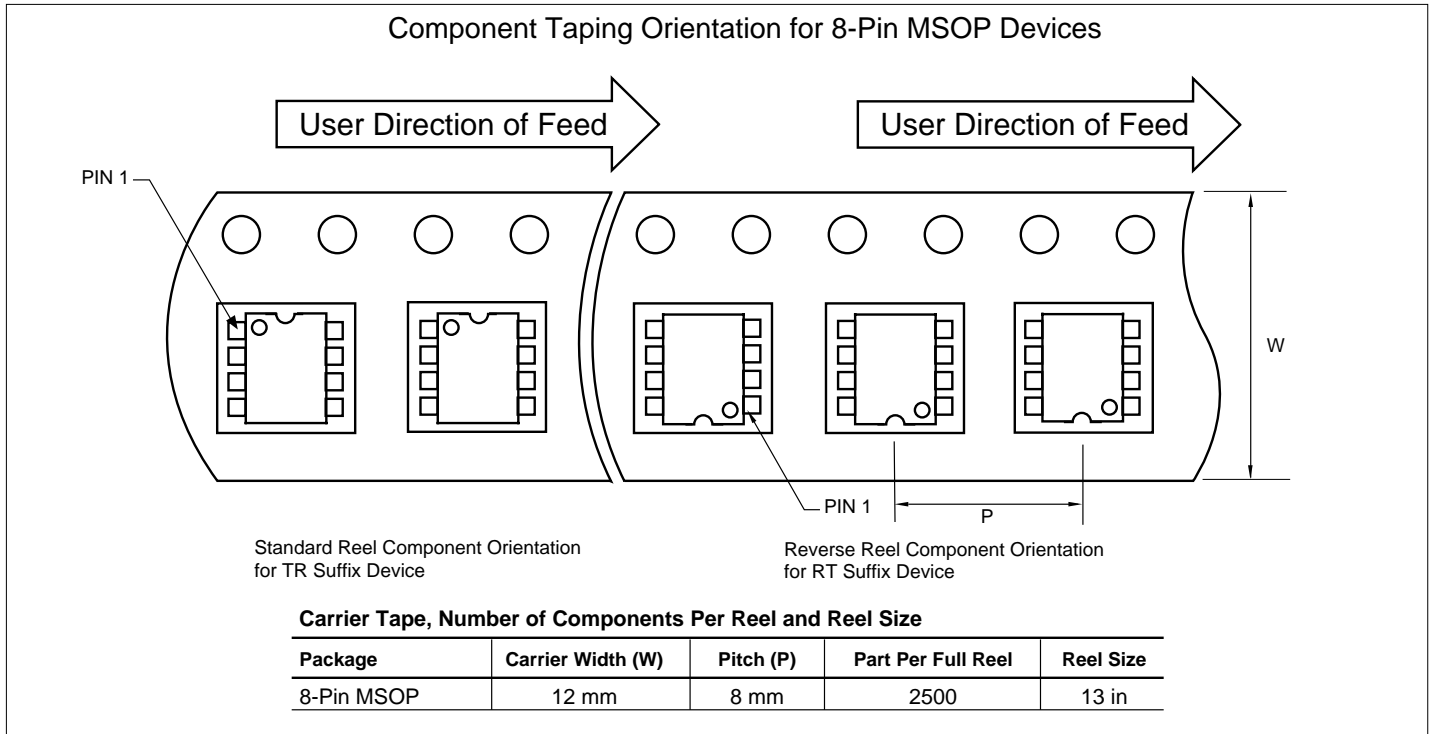

PACKAGE DIMENSIONS

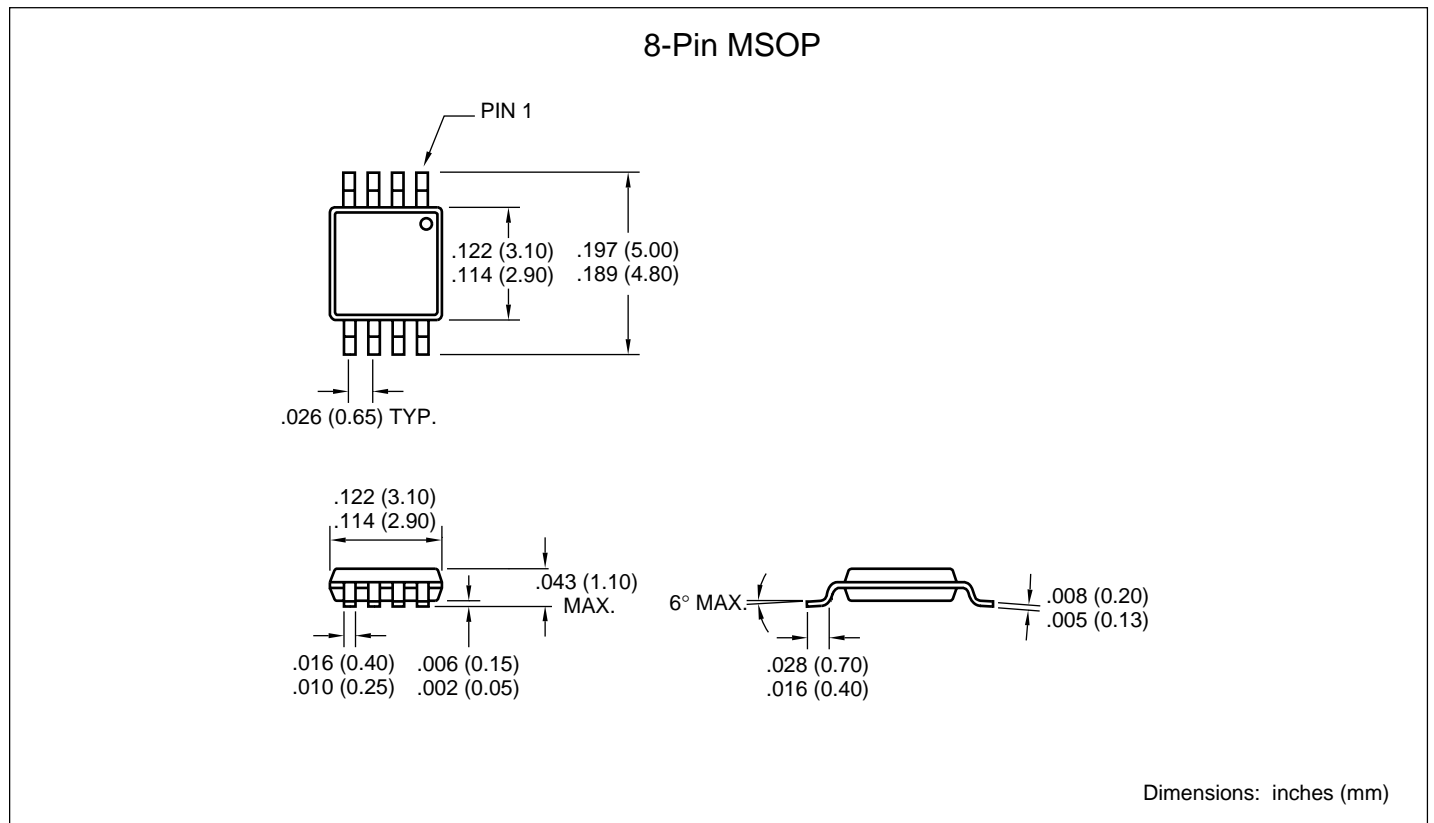

Information contained in this publication regarding device applications and the like is intended through suggestion only and may be superseded by updates. It is your responsibility to ensure that your application meets with your specifications. No representation or warranty is given and no liability is assumed by Microchip Technology Incorporated with respect to the accuracy or use of such information, or infringement of patents or other intellectual property rights arising from such use or otherwise. Use of Microchip's products as critical components in life support systems is not authorized except with express written approval by Microchip. No licenses are conveyed, implicitly or otherwise, under any intellectual property rights.

Trademarks

The Microchip name and logo, the Microchip logo, PIC, PICmicro, PICMASTER, PICSTART, PRO MATE, KEELOQ, SEEVAL, MPLAB and The Embedded Control Solutions Company are registered trademarks of Microchip Technology Incorporated in the U.S.A. and other countries.

Total Endurance, ICSP, In-Circuit Serial Programming, Filter-Lab, MXDEV, microID, *FlexROM*, *fuzzyLAB*, MPASM, MPLINK, MPLIB, PICC, PICDEM, PICDEM.net, ICEPIC, Migratable Memory, FanSense, ECONOMONITOR, Select Mode and microPort are trademarks of Microchip Technology Incorporated in the U.S.A.

Serialized Quick Term Programming (SQTP) is a service mark of Microchip Technology Incorporated in the U.S.A.

All other trademarks mentioned herein are property of their respective companies.

© 2001, Microchip Technology Incorporated, Printed in the U.S.A., All Rights Reserved.

 Printed on recycled paper.

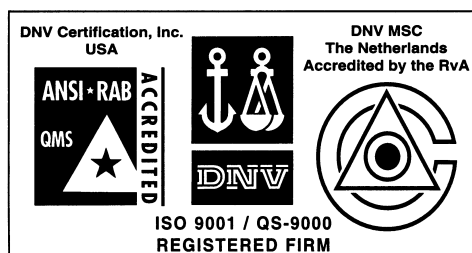

Microchip received QS-9000 quality system certification for its worldwide headquarters, design and wafer fabrication facilities in Chandler and Tempe, Arizona in July 1999. The Company's quality system processes and procedures are QS-9000 compliant for its PICmicro® 8-bit MCUs, KEELOQ® code hopping devices, Serial EEPROMs and microperipheral products. In addition, Microchip's quality system for the design and manufacture of development systems is ISO 9001 certified.



MICROCHIP

WORLDWIDE SALES AND SERVICE

AMERICAS

Corporate Office

2355 West Chandler Blvd.
Chandler, AZ 85224-6199
Tel: 480-792-7200 Fax: 480-792-7277
Technical Support: 480-792-7627
Web Address: <http://www.microchip.com>

Rocky Mountain

2355 West Chandler Blvd.
Chandler, AZ 85224-6199
Tel: 480-792-7966 Fax: 480-792-7456

Atlanta

500 Sugar Mill Road, Suite 200B
Atlanta, GA 30350
Tel: 770-640-0034 Fax: 770-640-0307

Austin - Analog

13740 North Highway 183
Building J, Suite 4
Austin, TX 78750
Tel: 512-257-3370 Fax: 512-257-8526

Boston

2 Lan Drive, Suite 120
Westford, MA 01886
Tel: 978-692-3848 Fax: 978-692-3821

Boston - Analog

Unit A-8-1 Millbrook Tarry Condominium
97 Lowell Road
Concord, MA 01742
Tel: 978-371-6400 Fax: 978-371-0050

Chicago

333 Pierce Road, Suite 180
Itasca, IL 60143
Tel: 630-285-0071 Fax: 630-285-0075

Dallas

4570 Westgrove Drive, Suite 160
Addison, TX 75001
Tel: 972-818-7423 Fax: 972-818-2924

Dayton

Two Prestige Place, Suite 130
Miamisburg, OH 45342
Tel: 937-291-1654 Fax: 937-291-9175

Detroit

Tri-Atria Office Building
32255 Northwestern Highway, Suite 190
Farmington Hills, MI 48334
Tel: 248-538-2250 Fax: 248-538-2260

Los Angeles

18201 Von Karman, Suite 1090
Irvine, CA 92612
Tel: 949-263-1888 Fax: 949-263-1338

New York

150 Motor Parkway, Suite 202
Hauppauge, NY 11788
Tel: 631-273-5305 Fax: 631-273-5335

San Jose

Microchip Technology Inc.
2107 North First Street, Suite 590
San Jose, CA 95131
Tel: 408-436-7950 Fax: 408-436-7955

Toronto

6285 Northam Drive, Suite 108
Mississauga, Ontario L4V 1X5, Canada
Tel: 905-673-0699 Fax: 905-673-6509

ASIA/PACIFIC

Australia

Microchip Technology Australia Pty Ltd
Suite 22, 41 Rawson Street
Epping 2121, NSW
Australia
Tel: 61-2-9868-6733 Fax: 61-2-9868-6755

China - Beijing

Microchip Technology Consulting (Shanghai)
Co., Ltd., Beijing Liaison Office
Unit 915
Bei Hai Wan Tai Bldg.
No. 6 Chaoyangmen Beidajie
Beijing, 100027, No. China
Tel: 86-10-85282100 Fax: 86-10-85282104

China - Chengdu

Microchip Technology Consulting (Shanghai)
Co., Ltd., Chengdu Liaison Office
Rm. 2401, 24th Floor,
Ming Xing Financial Tower
No. 88 TIDU Street
Chengdu 610016, China
Tel: 86-28-6766200 Fax: 86-28-6766599

China - Fuzhou

Microchip Technology Consulting (Shanghai)
Co., Ltd., Fuzhou Liaison Office
Rm. 531, North Building
Fujian Foreign Trade Center Hotel
73 Wusi Road
Fuzhou 350001, China
Tel: 86-591-7557563 Fax: 86-591-7557572

China - Shanghai

Microchip Technology Consulting (Shanghai)
Co., Ltd.
Room 701, Bldg. B
Far East International Plaza
No. 317 Xian Xia Road
Shanghai, 200051
Tel: 86-21-6275-5700 Fax: 86-21-6275-5060

China - Shenzhen

Microchip Technology Consulting (Shanghai)
Co., Ltd., Shenzhen Liaison Office
Rm. 1315, 13/F, Shenzhen Kerry Centre,
Renminnan Lu
Shenzhen 518001, China
Tel: 86-755-2350361 Fax: 86-755-2366086

Hong Kong

Microchip Technology Hongkong Ltd.
Unit 901-6, Tower 2, Metroplaza
223 Hing Fong Road
Kwai Fong, N.T., Hong Kong
Tel: 852-2401-1200 Fax: 852-2401-3431

India

Microchip Technology Inc.
India Liaison Office
Divyasree Chambers
1 Floor, Wing A (A3/A4)
No. 11, O'Shaughnessey Road
Bangalore, 560 025, India
Tel: 91-80-2290061 Fax: 91-80-2290062

Japan

Microchip Technology Japan K.K.
Benex S-1 6F
3-18-20, Shinyokohama
Kohoku-Ku, Yokohama-shi
Kanagawa, 222-0033, Japan
Tel: 81-45-471-6166 Fax: 81-45-471-6122

Korea

Microchip Technology Korea
168-1, Youngbo Bldg. 3 Floor
Samsung-Dong, Kangnam-Ku
Seoul, Korea 135-882
Tel: 82-2-554-7200 Fax: 82-2-558-5934

Singapore

Microchip Technology Singapore Pte Ltd.
200 Middle Road
#07-02 Prime Centre
Singapore, 188980
Tel: 65-334-8870 Fax: 65-334-8850

Taiwan

Microchip Technology Taiwan
11F-3, No. 207
Tung Hua North Road
Taipei, 105, Taiwan
Tel: 886-2-2717-7175 Fax: 886-2-2545-0139

EUROPE

Denmark

Microchip Technology Denmark ApS
Regus Business Centre
Lautrup høj 1-3
Ballerup DK-2750 Denmark
Tel: 45 4420 9895 Fax: 45 4420 9910

France

Arizona Microchip Technology SARL
Parc d'Activite du Moulin de Massy
43 Rue du Saule Trapu
Batiment A - 1er Etage
91300 Massy, France
Tel: 33-1-69-53-63-20 Fax: 33-1-69-30-90-79

Germany

Arizona Microchip Technology GmbH
Gustav-Heinemann Ring 125
D-81739 Munich, Germany
Tel: 49-89-627-144 0 Fax: 49-89-627-144-44

Germany - Analog

Lochamer Strasse 13
D-82152 Martinsried, Germany
Tel: 49-89-895650-0 Fax: 49-89-895650-22

Italy

Arizona Microchip Technology SRL
Centro Direzionale Colleoni
Palazzo Taurus 1 V. Le Colleoni 1
20041 Agrate Brianza
Milan, Italy
Tel: 39-039-65791-1 Fax: 39-039-6899883

United Kingdom

Arizona Microchip Technology Ltd.
505 Eskdale Road
Winnersh Triangle
Wokingham
Berkshire, England RG41 5TU
Tel: 44 118 921 5869 Fax: 44-118 921-5820

08/01/01