

TOSHIBA CMOS DIGITAL INTEGRATED CIRCUIT SILICON MONOLITHIC

# TC74HC590AP, TC74HC590AF

## 8 - BIT BINARY COUNTER / REGISTER WITH 3 - STATE OUTPUTS

The TC74HC590A is a high speed CMOS 8-BIT COUNTER/REGISTER fabricated with silicon gate C<sup>2</sup>MOS technology.

It achieves the high speed operation similar to equivalent LSTTL while maintaining the CMOS low power dissipation.

The internal counter counts on the positive going edge of Counter Clock (CCK) when Counter Clock Enable (CCKEN) is low. When Counter Clear (CCLR) is low, the internal counter is cleared asynchronously to the clock.

Data in the internal counter are loaded into the register at positive going edge of Register Clock (RCK), and the register outputs are controlled by enable input ( $\overline{G}$ ).

All inputs are equipped with protection circuits against static discharge or transient excess voltage.

**FEATURES :**

- High Speed..... $f_{MAX} = 62\text{MHz}(\text{typ.})$  at  $V_{CC} = 5\text{V}$
- Low Power Dissipation ..... $I_{CC} = 4\mu\text{A}(\text{Max.})$  at  $T_a = 25^\circ\text{C}$
- High Noise Immunity ..... $V_{NIH} = V_{NIL} = 28\% V_{CC}(\text{Min.})$
- Output Drive Capability..... 15 LSTTL Loads For QA~QH  
10 LSTTL Loads For  $\overline{RCO}$
- Symmetrical Output Impedance...  
 $|I_{OH}| = I_{OL} = 6\text{mA}(\text{Min.})$  For QA~QH  
 $|I_{OH}| = I_{OL} = 4\text{mA}(\text{Min.})$  For  $\overline{RCO}$
- Balanced Propagation Delays..... $t_{pLH} \approx t_{pHL}$
- Wide Operating Voltage Range.... $V_{CC}(\text{opr.}) = 2\text{V} \sim 6\text{V}$
- Pin and Function Compatible with 74LS590

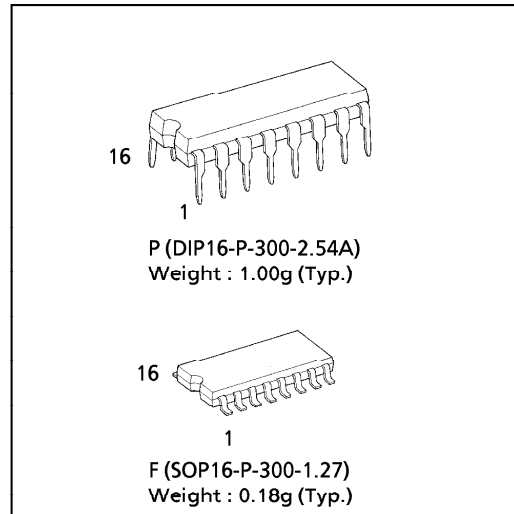

**PIN ASSIGNMENT**

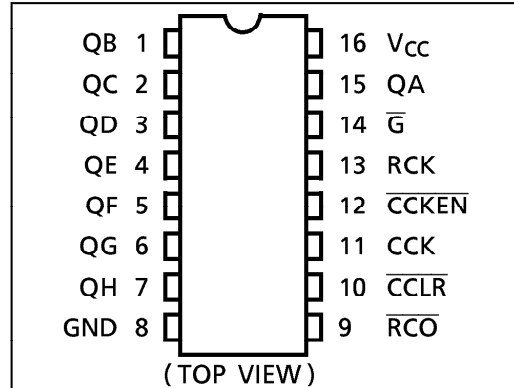

**TRUTH TABLE**

INPUT					FUNCTION
G	RCK	CCLR	CCKEN	CCK	
H	X	X	X	X	Q OUTPUTS DISABLE
L	X	X	X	X	Q OUTPUTS ENABLE
X	$\overline{\uparrow}$	X	X	X	COUNTER DATA IS STORED INTO REGISTER
X	$\overline{\downarrow}$	X	X	X	REGISTER STATE IS NOT CHANGED
X	X	L	X	X	COUNTER CLEAR
X	X	H	L	$\overline{\uparrow}$	ADVANCE ONE COUNT
X	X	H	L	$\overline{\downarrow}$	NO COUNT
X	X	H	H	X	NO COUNT

X : Don't care

$$\overline{\text{RCO}} = \text{QA}' \cdot \text{QB}' \cdot \text{QC}' \cdot \text{QD}' \cdot \text{QE}' \cdot \text{QF}' \cdot \text{QG}' \cdot \text{QH}'$$

(QA'~QH' : Internal outputs of the counter)

961001EBA2

● TOSHIBA is continually working to improve the quality and the reliability of its products. Nevertheless, semiconductor devices in general can malfunction or fail due to their inherent electrical sensitivity and vulnerability to physical stress. It is the responsibility of the buyer, when utilizing TOSHIBA products, to observe standards of safety, and to avoid situations in which a malfunction or failure of a TOSHIBA product could cause loss of human life, bodily injury or damage to property. In developing your designs, please ensure that TOSHIBA products are used within specified operating ranges as set forth in the most recent products specifications. Also, please keep in mind the precautions and conditions set forth in the TOSHIBA Semiconductor Reliability Handbook.

TIMING CHART

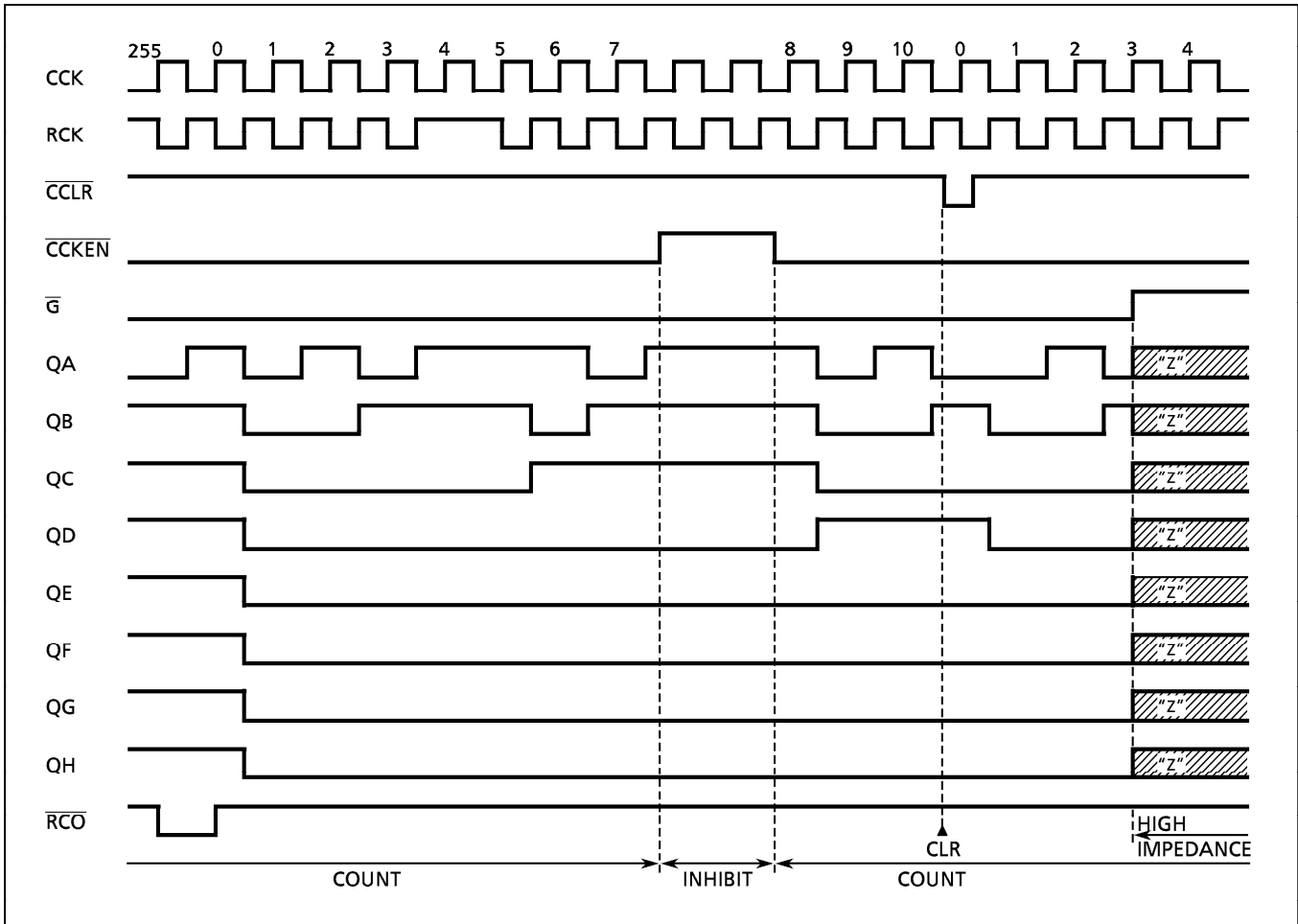

IEC LOGIC SYMBOL

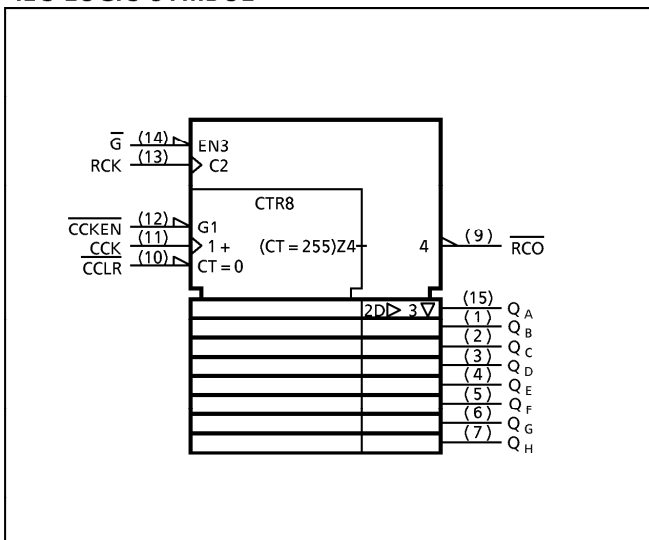

BLOCK DIAGRAM

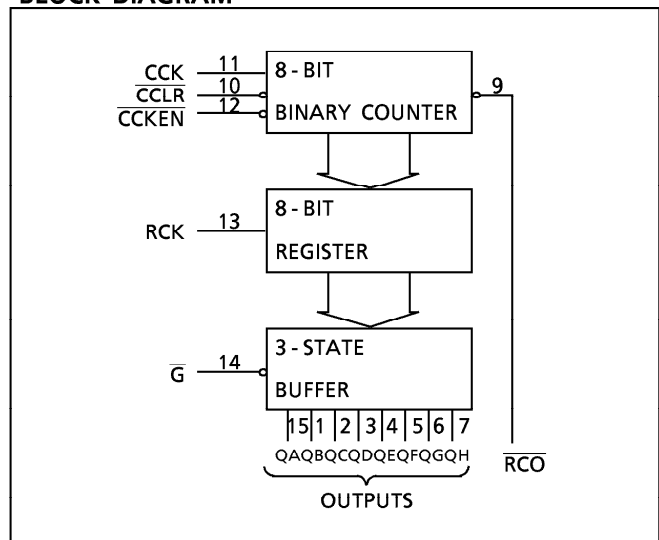

961001EBA2'

- The products described in this document are subject to foreign exchange and foreign trade control laws.
- The information contained herein is presented only as a guide for the applications of our products. No responsibility is assumed by TOSHIBA CORPORATION for any infringements of intellectual property or other rights of the third parties which may result from its use. No license is granted by implication or otherwise under any intellectual property or other rights of TOSHIBA CORPORATION or others.
- The information contained herein is subject to change without notice.

LOGIC DIAGRAM

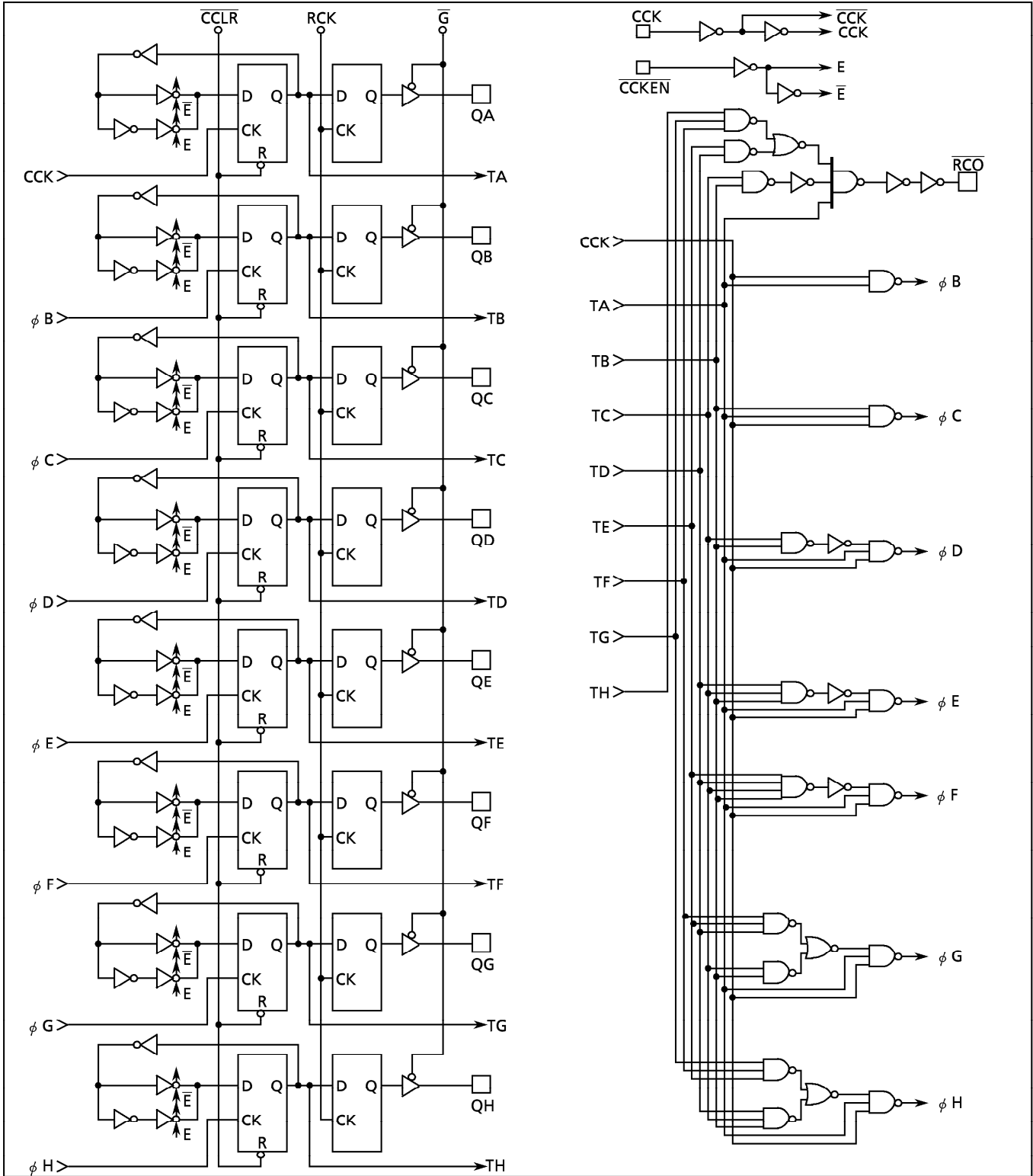

## ABSOLUTE MAXIMUM RATINGS

PARAMETER	SYMBOL	VALUE	UNIT
Supply Voltage Range	$V_{CC}$	$-0.5 \sim 7$	V
DC Input Voltage	$V_{IN}$	$-0.5 \sim V_{CC} + 0.5$	V
DC Output Voltage	$V_{OUT}$	$-0.5 \sim V_{CC} + 0.5$	V
Input Diode Current	$I_{IK}$	$\pm 20$	mA
Output Diode Current	$I_{OK}$	$\pm 20$	mA
DC Output Current (RCO) (QA~QB)	$I_{OUT}$	$\pm 25$ $\pm 35$	mA
DC $V_{CC}$ / Ground Current	$I_{CC}$	$\pm 75$	mA
Power Dissipation	$P_D$	500 (DIP)* / 180 (SOP)	mW
Storage Temperature	$T_{stg}$	$-65 \sim 150$	°C

\*500mW in the range of  $T_a = -40^\circ\text{C} \sim 65^\circ\text{C}$ . From  $T_a = 65^\circ\text{C}$  to  $85^\circ\text{C}$  a derating factor of  $-10\text{mW}/^\circ\text{C}$  shall be applied until 300mW.

## RECOMMENDED OPERATING CONDITIONS

PARAMETER	SYMBOL	VALUE	UNIT
Supply Voltage	$V_{CC}$	$2 \sim 6$	V
Input Voltage	$V_{IN}$	$0 \sim V_{CC}$	V
Output Voltage	$V_{OUT}$	$0 \sim V_{CC}$	V
Operating Temperature	$T_{opr}$	$-40 \sim 85$	°C
Input Rise and Fall Time	$t_r, t_f$	0~ 1000 ( $V_{CC} = 2.0\text{V}$ ) 0~ 500 ( $V_{CC} = 4.5\text{V}$ ) 0~ 400 ( $V_{CC} = 6.0\text{V}$ )	ns

**DC ELECTRICAL CHARACTERISTICS**

PARAMETER	SYMBOL	TEST CONDITION	V <sub>CC</sub> (V)	Ta = 25°C			Ta = -40~85°C		UNIT
				MIN.	TYP.	MAX.	MIN.	MAX.	
High - Level Input Voltage	V <sub>IH</sub>		2.0	1.50	—	—	1.50	—	V
			4.5	3.15	—	—	3.15	—	
			6.0	4.20	—	—	4.20	—	
Low - Level Input Voltage	V <sub>IL</sub>		2.0	—	—	0.50	—	0.50	V
			4.5	—	—	1.35	—	1.35	
			6.0	—	—	1.80	—	1.80	
High - Level Output Voltage	V <sub>OH</sub>	V <sub>IN</sub> = V <sub>IH</sub> or V <sub>IL</sub> I <sub>OH</sub> = -20μA	2.0	1.9	2.0	—	1.9	—	V
			4.5	4.4	4.5	—	4.4	—	
			6.0	5.9	6.0	—	5.9	—	
High - Level Output Voltage	V <sub>OH</sub>	R $\overline{CO}$ I <sub>OH</sub> = -4 mA I <sub>OH</sub> = -5.2 mA	4.5	4.18	4.31	—	4.31	—	V
			6.0	5.68	5.80	—	5.63	—	
			6.0	5.68	5.80	—	5.63	—	
High - Level Output Voltage	V <sub>OH</sub>	QA~QH I <sub>OH</sub> = -6 mA I <sub>OH</sub> = -7.8 mA	4.5	4.18	4.31	—	4.13	—	V
			6.0	5.68	5.80	—	5.63	—	
			6.0	5.68	5.80	—	5.63	—	
Low - Level Output Voltage	V <sub>OL</sub>	V <sub>IN</sub> = V <sub>IH</sub> or V <sub>IL</sub> I <sub>OL</sub> = 20μA	2.0	—	0.0	0.1	—	0.1	V
			4.5	—	0.0	0.1	—	0.1	
			6.0	—	0.0	0.1	—	0.1	
Low - Level Output Voltage	V <sub>OL</sub>	R $\overline{CO}$ I <sub>OL</sub> = 4 mA I <sub>OL</sub> = 5.2 mA	4.5	—	0.17	0.26	—	0.33	V
			6.0	—	0.18	0.26	—	0.33	
			6.0	—	0.18	0.26	—	0.33	
Low - Level Output Voltage	V <sub>OL</sub>	QA~QH I <sub>OL</sub> = 6 mA I <sub>OL</sub> = 7.8 mA	4.5	—	0.17	0.26	—	0.33	V
			6.0	—	0.18	0.26	—	0.33	
			6.0	—	0.18	0.26	—	0.33	
3 - State Output Off - State Current	I <sub>OZ</sub>	V <sub>IN</sub> = V <sub>IH</sub> or V <sub>IL</sub> V <sub>OUT</sub> = V <sub>CC</sub> or GND	6.0	—	—	± 0.5	—	± 5.0	μA
Input Leakage Current	I <sub>IN</sub>	V <sub>IN</sub> = V <sub>CC</sub> or GND	6.0	—	—	± 0.1	—	± 1.0	
Quiescent Supply Current	I <sub>CC</sub>	V <sub>IN</sub> = V <sub>CC</sub> or GND	6.0	—	—	4.0	—	40.0	

**TIMING REQUIREMENTS (Input t<sub>r</sub> = t<sub>f</sub> = 6ns)**

PARAMETER	SYMBOL	TEST CONDITION	V <sub>CC</sub> (V)	Ta = 25°C		Ta = -40~85°C	UNIT
				TYP.	LIMIT	LIMIT	
Minimum Pulse Width (CCK, RCK)	t <sub>w(H)</sub> t <sub>w(L)</sub>		2.0	—	75	95	ns
			4.5	—	15	19	
			6.0	—	13	16	
Minimum Pulse Width (CCLR)	t <sub>w(L)</sub>		2.0	—	75	95	ns
			4.5	—	15	19	
			6.0	—	13	16	
Minimum Set-up Time (CCKEN-CCK)	t <sub>s</sub>		2.0	—	100	125	ns
			4.5	—	20	25	
			6.0	—	17	21	
Minimum Set-up Time (CCK-RCK)	t <sub>s</sub>		2.0	—	200	250	ns
			4.5	—	40	50	
			6.0	—	34	43	
Minimum Hold Time	t <sub>h</sub>		2.0	—	0	0	ns
			4.5	—	0	0	
			6.0	—	0	0	
Minimum Removal Time (CCLR)	t <sub>rem</sub>		2.0	—	75	95	ns
			4.5	—	15	19	
			6.0	—	13	16	
Clock Frequency	f		2.0	—	6	5	MHz
			4.5	—	33	26	
			6.0	—	39	31	

**AC ELECTRICAL CHARACTERISTICS (  $C_L = 15\text{pF}$ ,  $V_{CC} = 5\text{V}$ ,  $T_a = 25^\circ\text{C}$ , Input  $t_r = t_f = 6\text{ns}$  )**

PARAMETER	SYMBOL	TEST CONDITION	MIN.	TYP.	MAX.	UNIT
Output Transition Time ( $\overline{\text{RCO}}$ )	$t_{\text{TLH}}$ $t_{\text{THL}}$		—	4	8	ns
Propagation Delay Time ( $\text{CCK} - \overline{\text{RCO}}$ )	$t_{\text{pLH}}$ $t_{\text{pHL}}$		—	18	28	
Propagation Delay Time ( $\text{CCK} - \overline{\text{RCO}}$ )	$t_{\text{pLH}}$		—	20	30	
Maximum Clock Frequency	$f_{\text{MAX}}$		32	62	—	MHz

**AC ELECTRICAL CHARACTERISTICS ( Input  $t_r = t_f = 6\text{ns}$  )**

PARAMETER	SYMBOL	TEST CONDITION	CL (pF)	V <sub>CC</sub> (V)	Ta = 25°C			Ta = -40~85°C		UNIT
					MIN.	TYP.	MAX.	MIN.	MAX.	
Output Transition Time ( $Q_n$ )	$t_{\text{TLH}}$ $t_{\text{THL}}$		50	2.0	—	25	60	—	75	ns
				4.5	—	7	12	—	15	
				6.0	—	6	10	—	13	
Output Transition Time ( $\overline{\text{RCO}}$ )	$t_{\text{TLH}}$ $t_{\text{THL}}$		50	2.0	—	30	75	—	95	
				4.5	—	8	15	—	19	
				6.0	—	7	13	—	16	
Propagation Delay Time ( $\text{CCK} - \overline{\text{RCO}}$ )	$t_{\text{pLH}}$ $t_{\text{pHL}}$		50	2.0	—	75	163	—	205	
				4.5	—	22	33	—	41	
				6.0	—	17	28	—	35	
Propagation Delay Time ( $\text{CCLR} - \overline{\text{RCO}}$ )	$t_{\text{pLH}}$		50	2.0	—	78	175	—	220	
				4.5	—	23	35	—	44	
				6.0	—	18	30	—	37	
Propagation Delay Time ( $\text{RCK} - Q_n$ )	$t_{\text{pLH}}$ $t_{\text{pHL}}$		50	2.0	—	62	145	—	180	
				4.5	—	19	29	—	36	
				6.0	—	15	25	—	31	
			150	2.0	—	78	185	—	230	
				4.5	—	24	37	—	46	
				6.0	—	19	31	—	39	
Output Enable time	$t_{\text{pZL}}$ $t_{\text{pZH}}$	$R_L = 1\text{k}\Omega$	50	2.0	—	43	105	—	130	
				4.5	—	14	21	—	26	
				6.0	—	12	18	—	22	
			150	2.0	—	58	150	—	190	
				4.5	—	19	30	—	38	
				6.0	—	16	26	—	33	
Output Disable time	$t_{\text{pLZ}}$ $t_{\text{pHZ}}$	$R_L = 1\text{k}\Omega$	50	2.0	—	33	105	—	130	
				4.5	—	16	21	—	26	
				6.0	—	12	18	—	22	
Maximum Clock Frequency	$f_{\text{MAX}}$		50	2.0	6	12	—	5	—	
				4.5	30	51	—	24	—	
				6.0	35	80	—	28	—	
Input Capacitance	$C_{\text{IN}}$				—	5	10	—	10	pF
Power Dissipation Capacitance	$C_{\text{PD}}(1)$				—	34	—	—	—	

Note(1)  $C_{\text{PD}}$  is defined as the value of the internal equivalent capacitance which is calculated from the operating current consumption without load.

Average operating current can be obtained by the equation :

$$I_{\text{CC}}(\text{opr}) = C_{\text{PD}} \cdot V_{\text{CC}} \cdot f_{\text{IN}} + I_{\text{CC}}$$

**DIP 16PIN OUTLINE DRAWING (DIP16-P-300-2.54A)**

Unit in mm

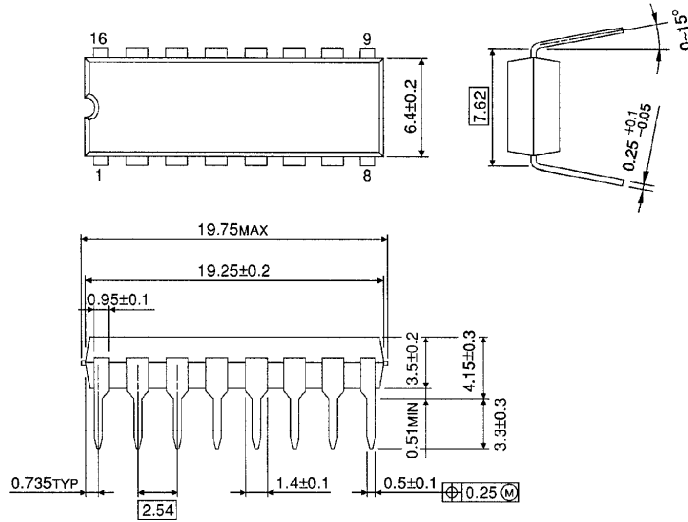

Weight : 1.00g (Typ.)

**SOP 16PIN (200mil BODY) OUTLINE DRAWING (SOP16-P-300-1.27)**

Unit in mm

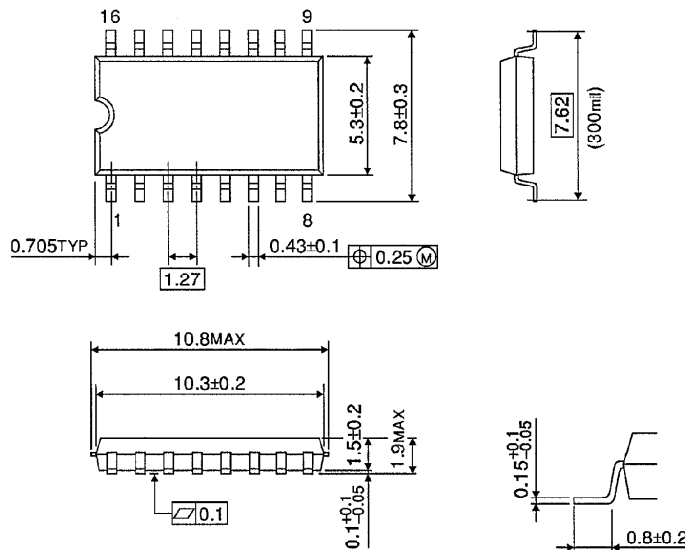

Weight : 0.18g (Typ.)