

TA7784P

DUAL PREAMPLIFIER FOR AUTOREVERSE

The TA7784P is dual preamplifier for autoreverse type and W-cassette type tape player.

This IC contains dual preamplifier, forward / reverse control switches and metal / normal tape equalizer control switches.

FEATURES

- Built-in Forward / Reverse (TAPE1 / TAPE2) Control Switches.
- Built-in Metal / Normal Tape Equalizer Control Switches.
- High Voltage Gain
: $G_{VO} = 95\text{dB}$ (Typ.) ($V_{CC} = 6\text{V}$, $f = 1\text{kHz}$)
- Operating Supply Voltage Range
: $V_{CC}(\text{opr}) = 3.5 \sim 15\text{V}$ ($T_a = 25^\circ\text{C}$)
- Input Coupling Capacitor Less
- Low Noise (Equivalent Input Noise Voltage)
: $V_{ni} = 1.0\mu\text{V}_{\text{rms}}$ (Typ.)
($R_g = 600\Omega$, $\text{BW} = 20 \sim 20\text{kHz}$, NAB EQ)

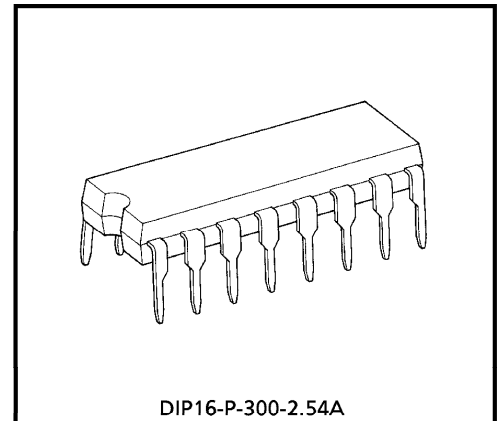

DIP16-P-300-2.54A
Weight : 1.00g (Typ.)

BLOCK DIAGRAM

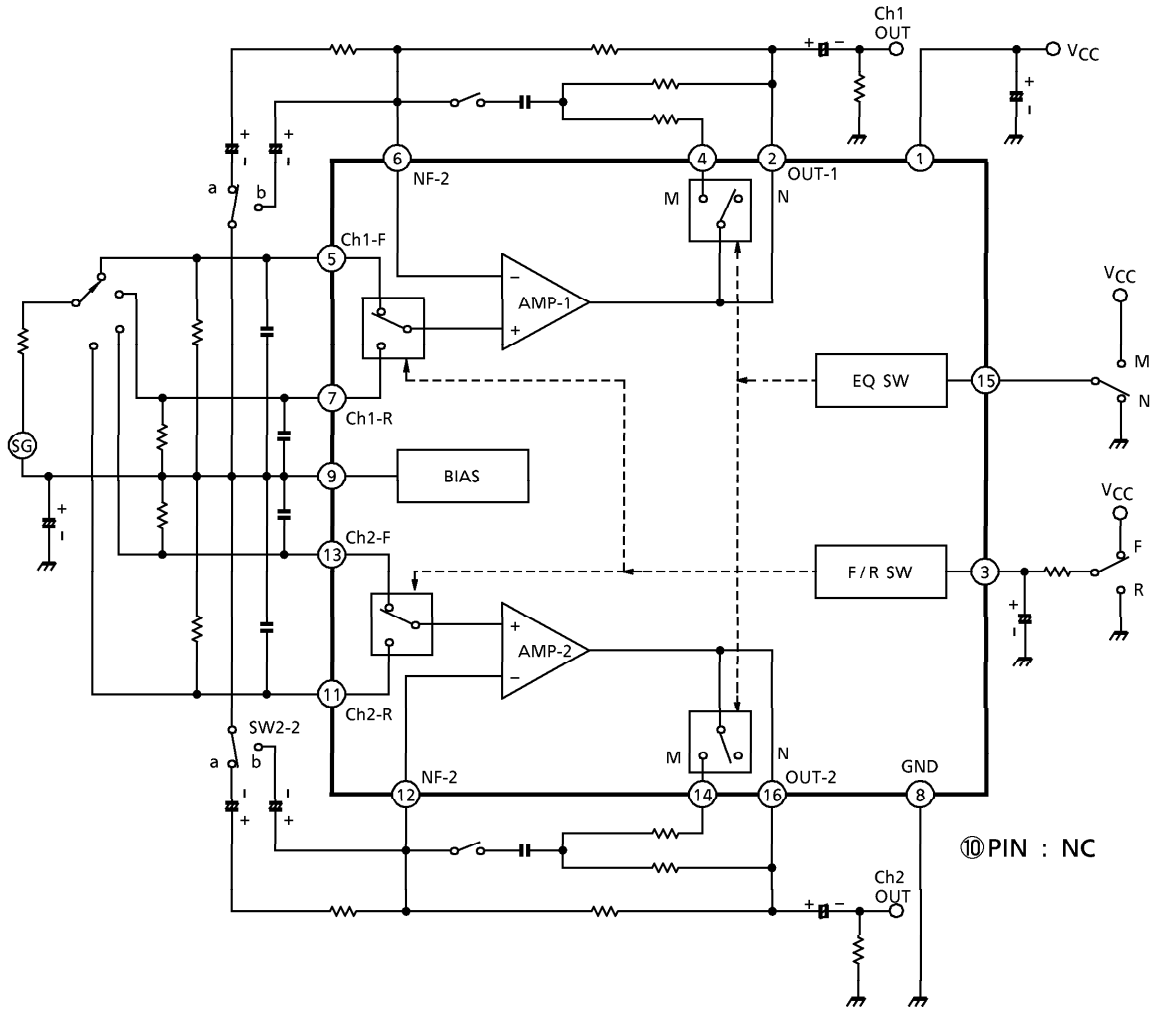

APPLICATION INFORMATION

(1) Forward / reverse select switch

① Threshold voltage

Pin③ is coupled to the base of Q1 (PNP-Tr) as shown Fig.1.
Threshold voltage

REVERSE	0~0.3V
FORWARD	1.1~V _{CC}

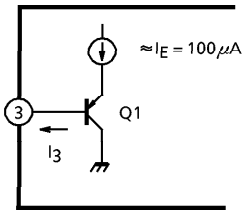

Fig.1

② The recommended forward / reverse select circuit is shown in Fig.2.

③ I₃ (In Fig.1)

$I_3 = 12 \mu A$ (Max.) (T_a = 25°C)

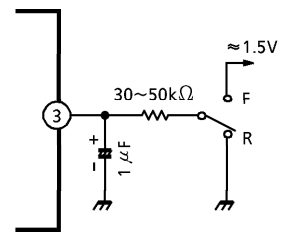

Fig.2

(2) Equalizer control switch

Pin⑮ is coupled to the base of Q2 (PNP-Tr) as shown Fig.3.
The emitter potential of Q2 is 2.6Vdc.

Threshold voltage

METAL	2.1~V _{CC}
NORMAL	0~1.2V

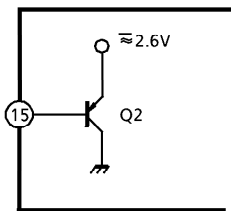

Fig.3

(3) C2~C5

Capacitor C2~C5 may be required for preventing a instability caused by the pattern layout or interference of external high frequency signal.

MAXIMUM RATINGS (Ta = 25°C)

CHARACTERISTIC	SYMBOL	RATING	UNIT
Supply Voltage	V _{CC}	16	V
Power Dissipation	P _D (Note)	750	mW
Operating Temperature	T _{opr}	- 30~75	°C
Storage Temperature	T _{stg}	- 55~150	°C

(Note) Derated above Ta = 25°C in the proportion of 6mW / °C.

ELECTRICAL CHARACTERISTICS

(Unless otherwise specified, V_{CC} = 6V, f = 1kHz, R_L = 10kΩ, R_g = 600Ω, Ta = 25°C, metal EQ)

CHARACTERISTIC	SYMBOL	TEST CIR-CUIT	TEST CONDITION	MIN.	TYP.	MAX.	UNIT
Quiescent Current	I _{CCQ} (1)	—	V _{in} = 0, NORMAL EQ	—	5.5	—	mA
	I _{CCQ} (2)	—	V _{in} = 0, METAL EQ	—	7.0	11	
Open Loop Voltage Gain	G _{vo}	—	C _f = 100μF, R _f = 0	—	95	—	dB
Maximum Output Voltage	V _{om}	—	THD = 0.5%	1.1	1.5	—	V _{rms}
Total Harmonic Distortion	THD	—	V _{out} = 0.5V _{rms}	—	0.035	0.12	%
Equivalent Input Noise Voltage	V _{in}	—	R _g = 620Ω, NAB BW = 20Hz~20kHz, Nor. EQ	—	1.0	1.7	μV _{rms}
Ripple Rejection	R.R.	—	f _{ripple} = 100Hz, V _{in} = 1V _{rms}	—	55	—	dB
Cross Talk	C.T.	—	V _{out} = 0.775V _{rms} (0dBm)	50	60	—	dB
Forward / Reverse Cross Talk	C.T. (F / R)	—	V _{out} = 0.775V _{rms} (0dBm)	60	70	—	dB

TYPICAL DC VOLTAGE OF EACH TERMINAL (V_{CC} = 6V, Ta = 25°C, dual mode test circuit)

TERMINAL No.	1	2	3	4	5	6	7	8	9	10	11	12	13	14	15	16
DC-VOLTAGE (V)	V _{CC}	2.3	$\frac{V_{CC}}{GND}$	2.2	2.2	2.2	2.2	GND	2.2	NC	2.2	2.2	2.2	2.2	$\frac{V_{CC}}{GND}$	2.2

TEST CIRCUIT

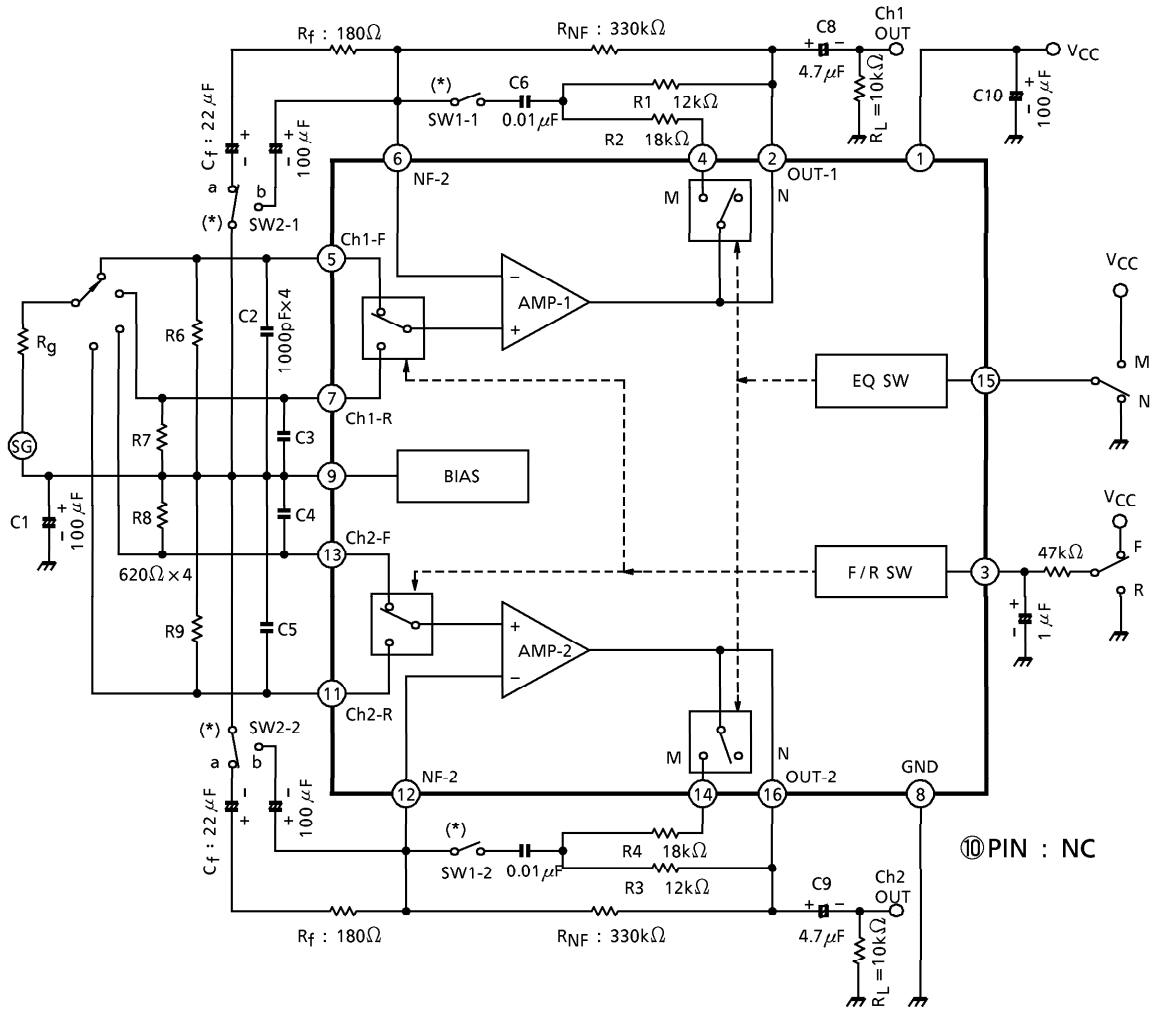

(*) G_{VO} TEST : SW1-1, 2-OFF, SW2-1, 2-b

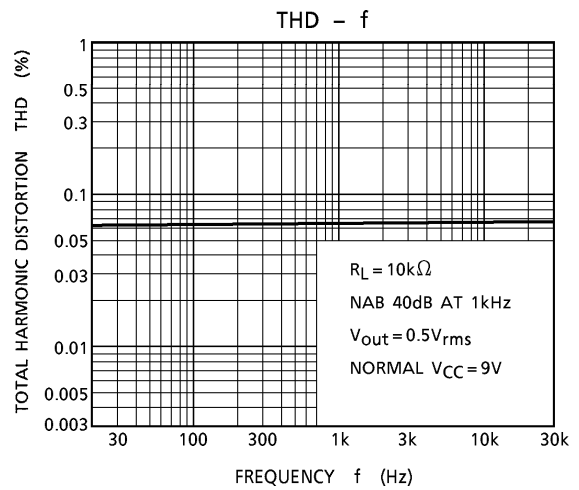
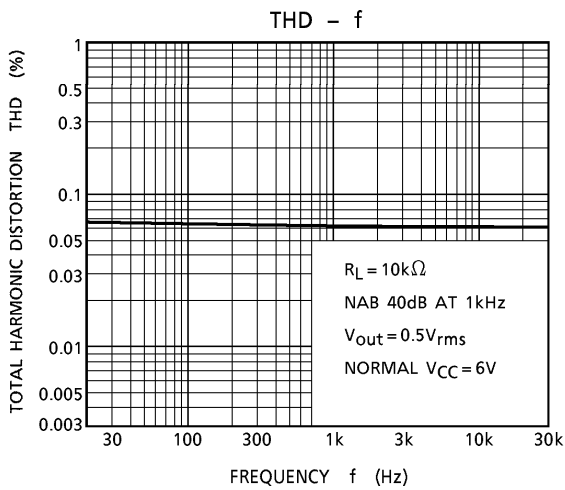
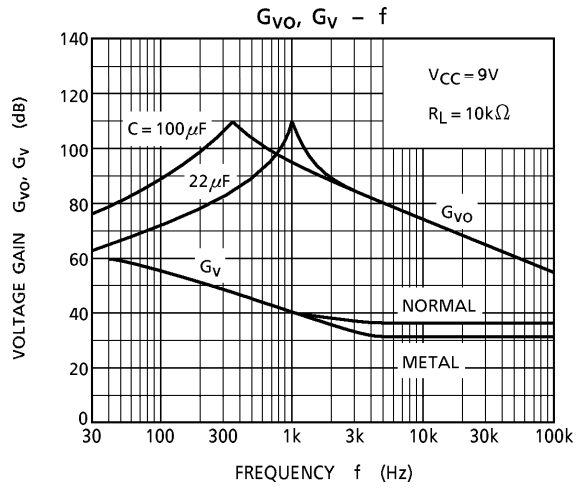
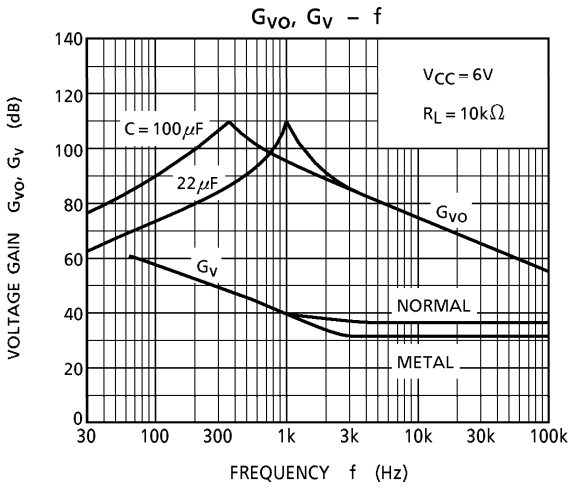
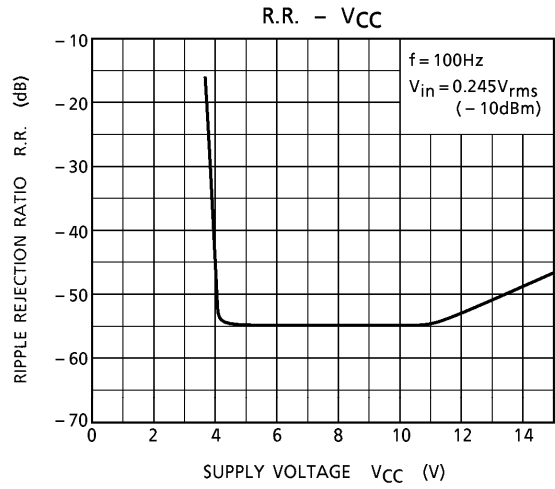
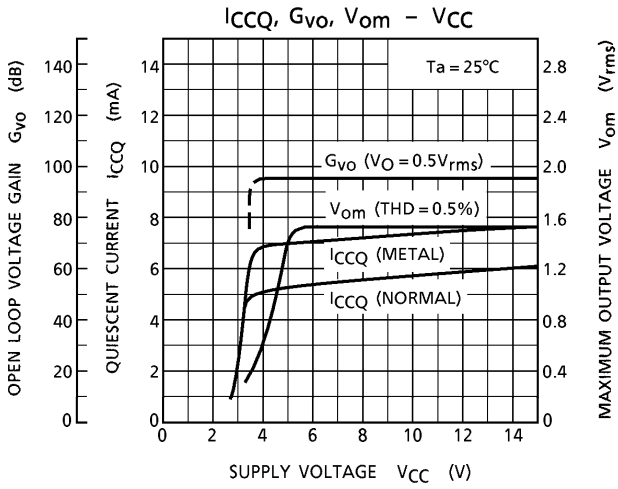

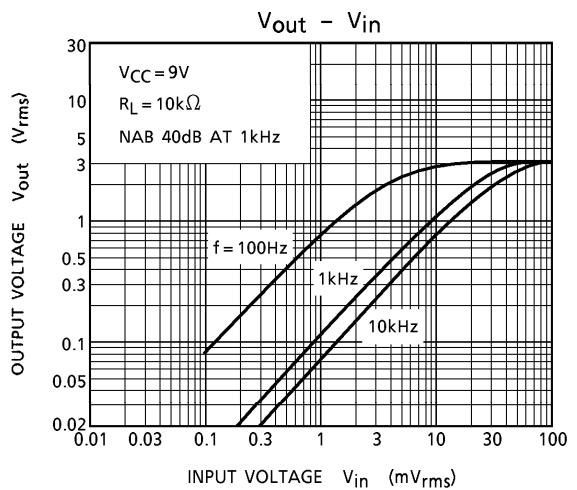
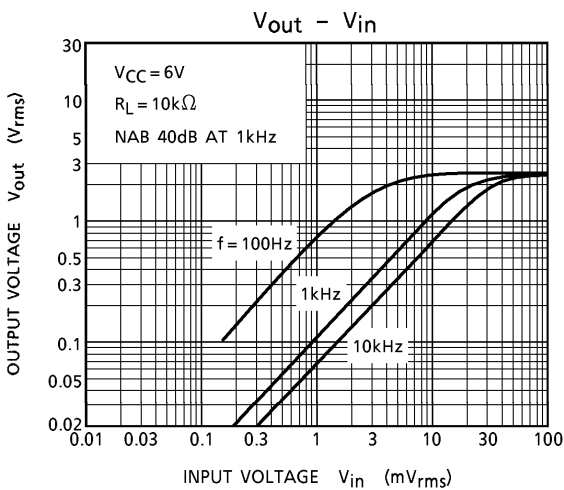
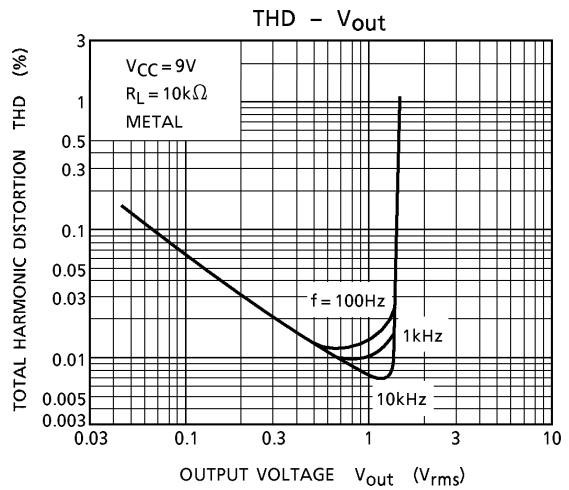
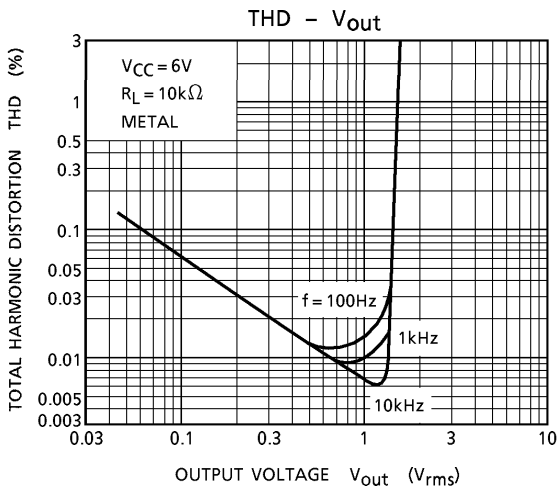
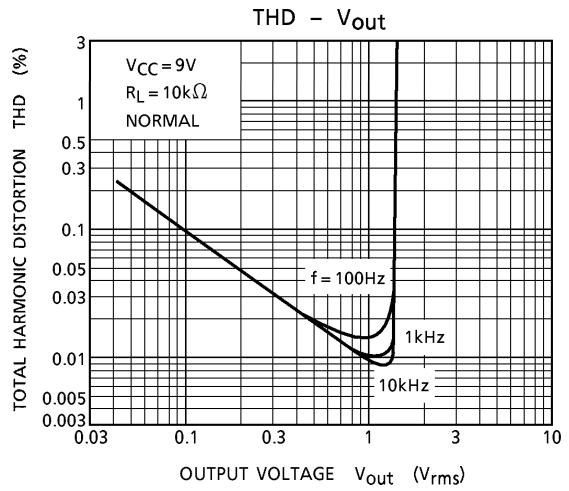
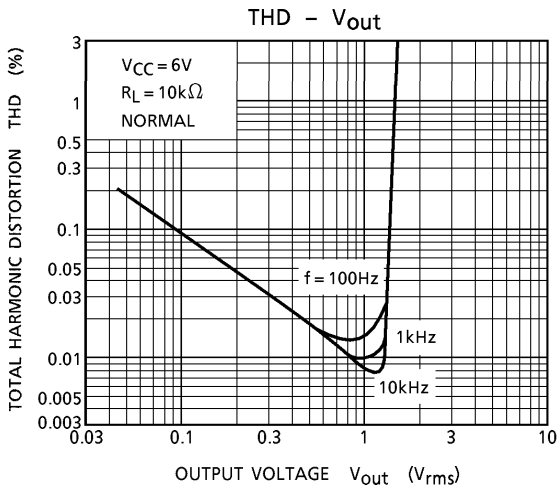

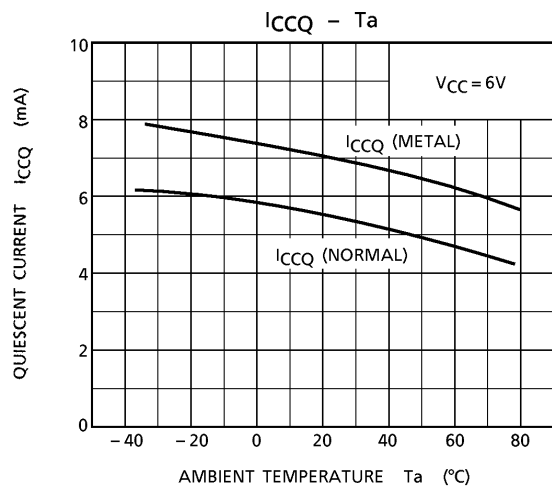
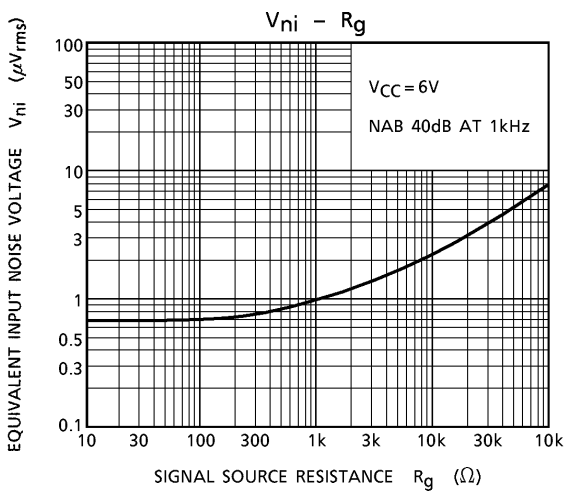
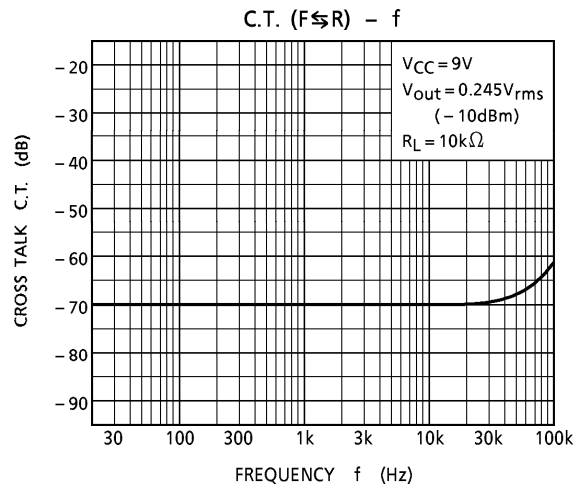
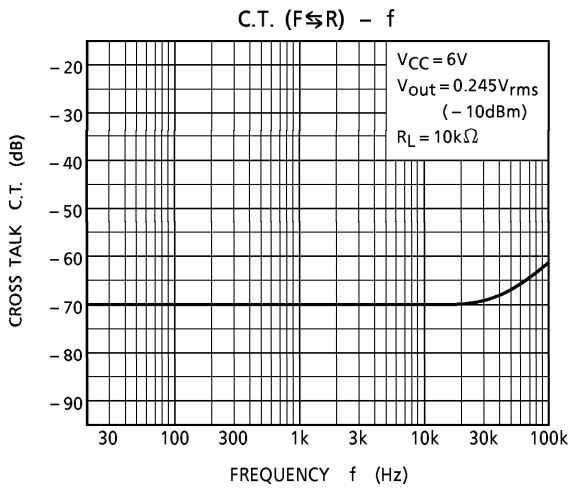
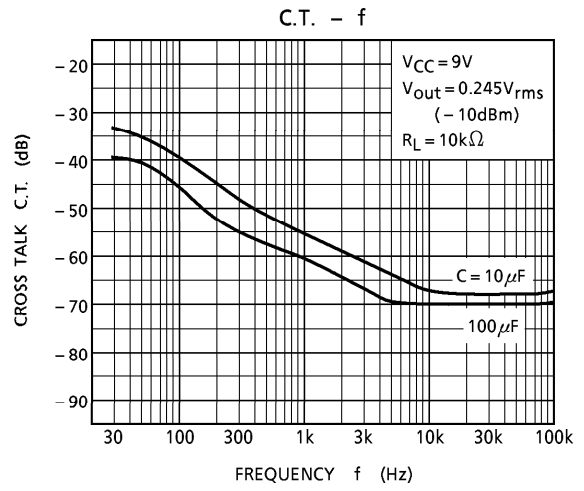
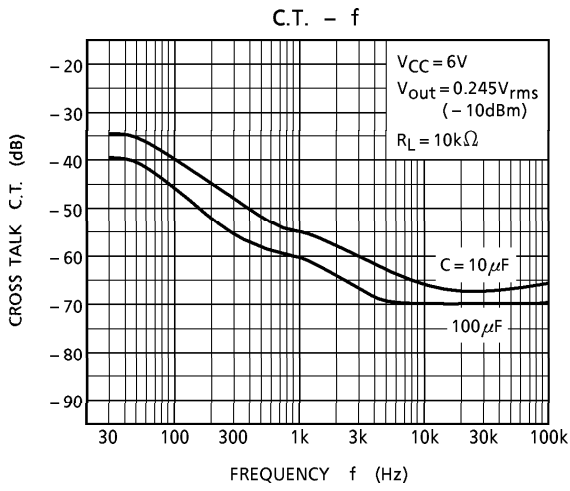

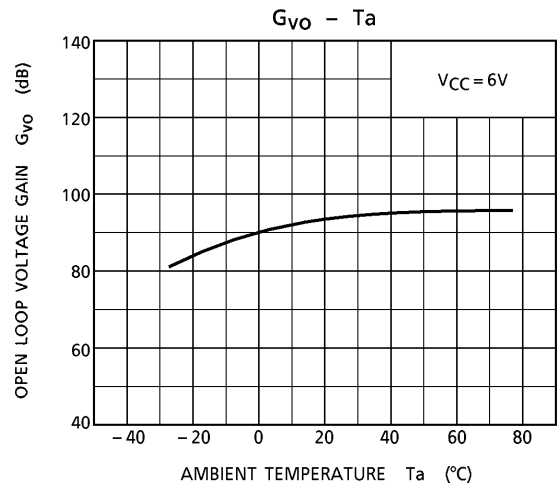
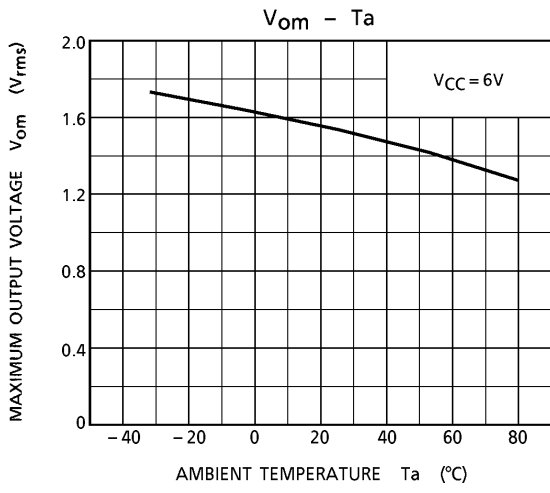

APPLICATION 1 (Double cassette player)

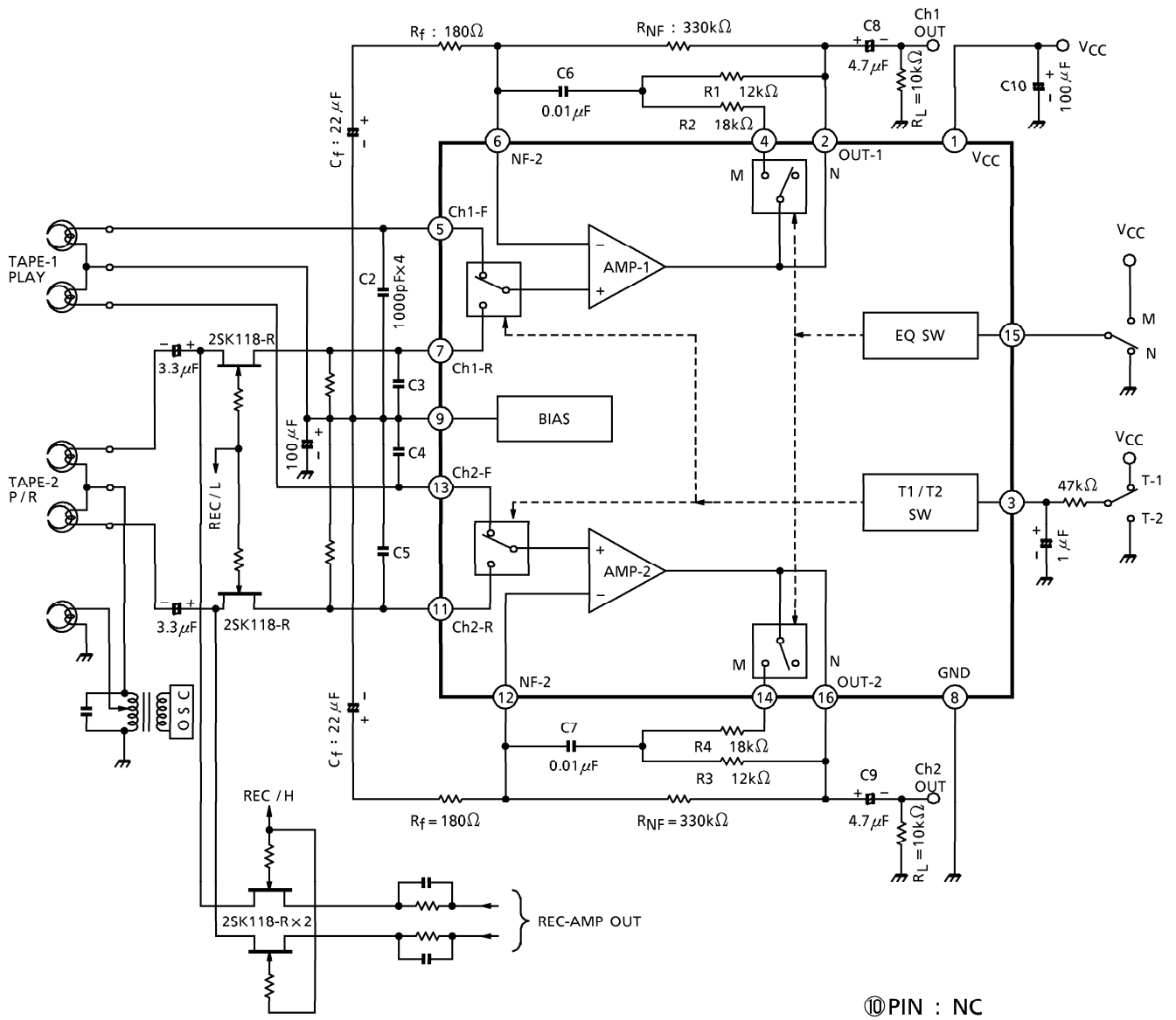

APPLICATION 2 (Autoreverse)

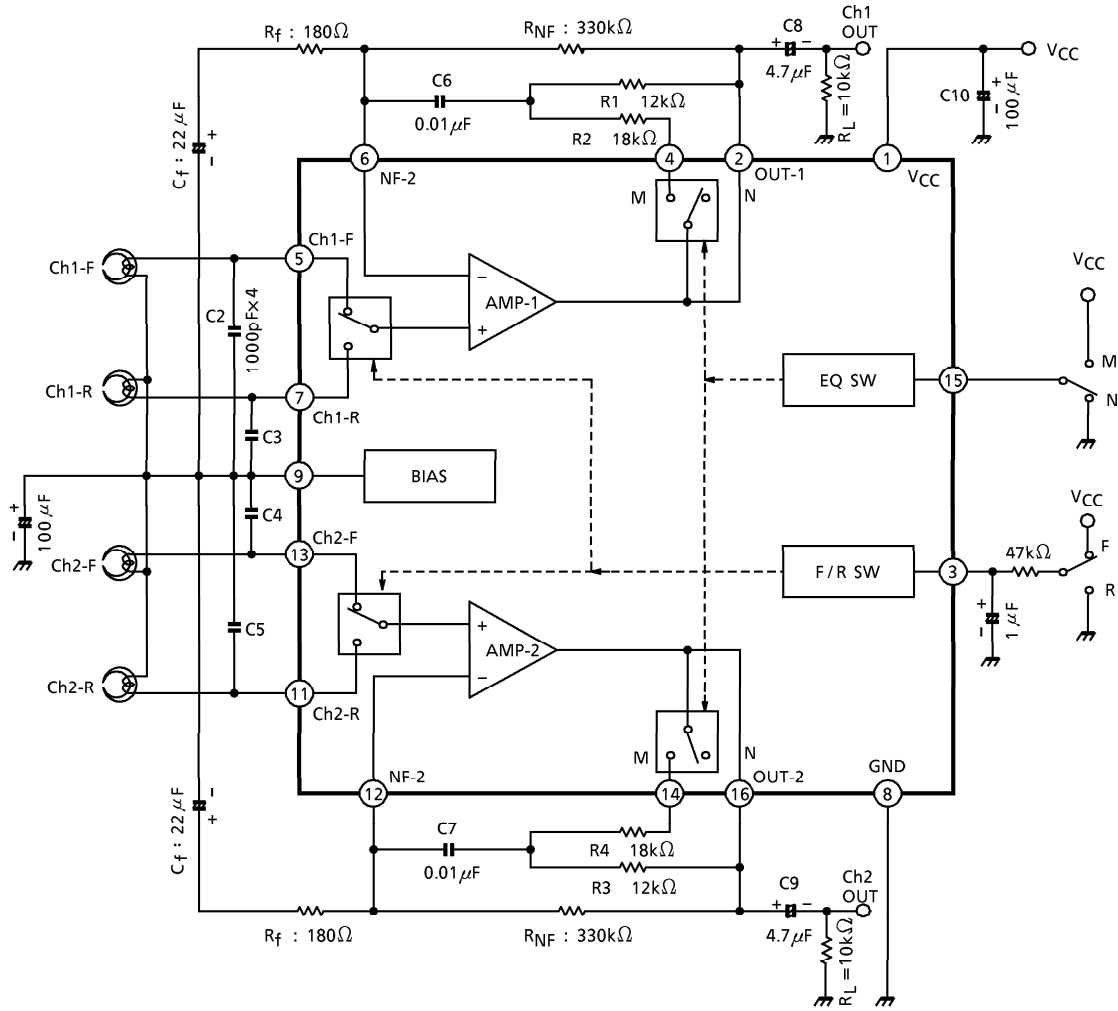

⑩ PIN : NC

PACKAGE DIMENSIONS
DIP16-P-300-2.54A

Unit : mm

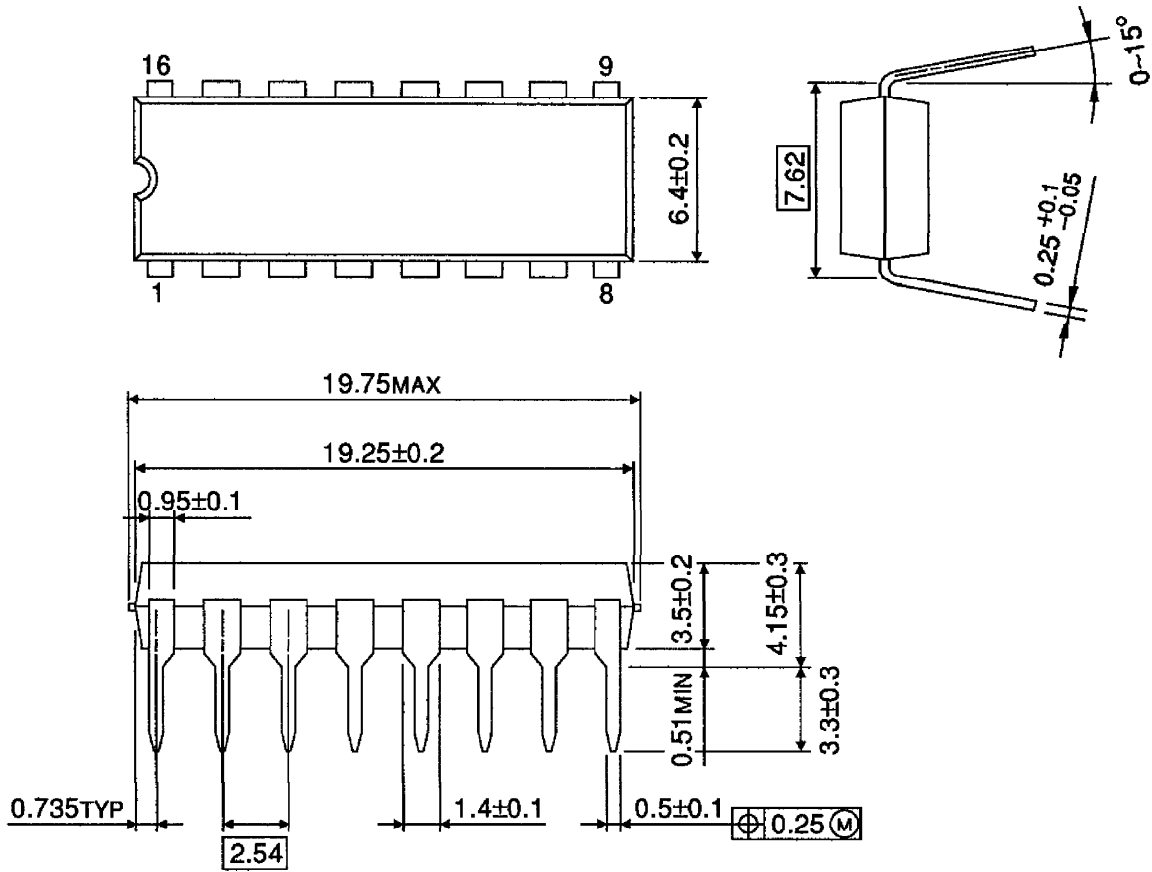

Weight : 1.00g (Typ.)

RESTRICTIONS ON PRODUCT USE

000707EBA

- TOSHIBA is continually working to improve the quality and reliability of its products. Nevertheless, semiconductor devices in general can malfunction or fail due to their inherent electrical sensitivity and vulnerability to physical stress. It is the responsibility of the buyer, when utilizing TOSHIBA products, to comply with the standards of safety in making a safe design for the entire system, and to avoid situations in which a malfunction or failure of such TOSHIBA products could cause loss of human life, bodily injury or damage to property. In developing your designs, please ensure that TOSHIBA products are used within specified operating ranges as set forth in the most recent TOSHIBA products specifications. Also, please keep in mind the precautions and conditions set forth in the "Handling Guide for Semiconductor Devices," or "TOSHIBA Semiconductor Reliability Handbook" etc..
- The TOSHIBA products listed in this document are intended for usage in general electronics applications (computer, personal equipment, office equipment, measuring equipment, industrial robotics, domestic appliances, etc.). These TOSHIBA products are neither intended nor warranted for usage in equipment that requires extraordinarily high quality and/or reliability or a malfunction or failure of which may cause loss of human life or bodily injury ("Unintended Usage"). Unintended Usage include atomic energy control instruments, airplane or spaceship instruments, transportation instruments, traffic signal instruments, combustion control instruments, medical instruments, all types of safety devices, etc.. Unintended Usage of TOSHIBA products listed in this document shall be made at the customer's own risk.
- The products described in this document are subject to the foreign exchange and foreign trade laws.
- The information contained herein is presented only as a guide for the applications of our products. No responsibility is assumed by TOSHIBA CORPORATION for any infringements of intellectual property or other rights of the third parties which may result from its use. No license is granted by implication or otherwise under any intellectual property or other rights of TOSHIBA CORPORATION or others.
- The information contained herein is subject to change without notice.