

Si photodiode

S7686

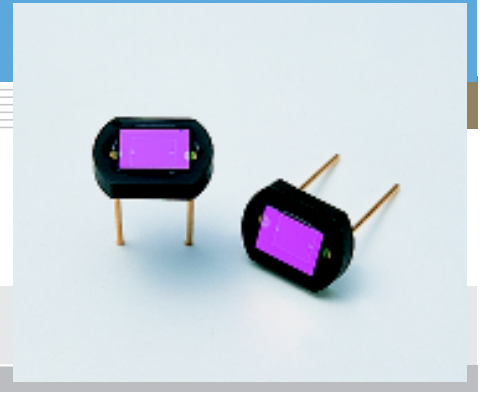

Photodiode with sensitivity close to the human eye

S7686 is a Si photodiode having a spectral response characteristic that is more similar to the human eye sensitivity (luminous spectral efficiency) than our conventional visual-compensated sensors (S1133, etc.).

Features

- Spectral response analogous to CIE luminous spectral efficiency
Spectral response range: 480 to 660 nm
Peak sensitivity wavelength: 550 nm
- Ceramic package for reliability
- Active area: 2.4 × 2.8 mm
- High-speed response: 0.5 μs ($V_R=0$ V, $R_L=1$ kΩ)
- fs value: 8 % Typ. (vertical light input)

Applications

- Illuminometer
- Luminance meter

■ Absolute maximum ratings ($T_a=25$ °C)

Parameter	Symbol	Value	Unit
Reverse voltage	V_R Max.	10	V
Operating temperature	T_{opr}	-10 to +60	°C
Storage temperature	T_{stg}	-20 to +70	°C

■ Electrical and optical characteristics ($T_a=25$ °C)

Parameter	Symbol	Condition	Min.	Typ.	Max.	Unit
Spectral response range	λ		-	480 to 660	-	nm
Peak sensitivity wavelength	λ_p		-	550	-	nm
Photo sensitivity	S	$\lambda=\lambda_p$	-	0.38	-	A/W
Short circuit current	I_{sc}	100 k, 2856 K	-	0.45	-	μA
Dark current	I_D	$V_R=1$ V	-	2	20	pA
Rise time	t_r	$V_R=0$ V, $R_L=1$ kΩ	-	0.5	-	μs
Terminal capacitance	C_t	$V_R=0$ V, $f=10$ kHz	-	200	-	pF

■ Spectral response

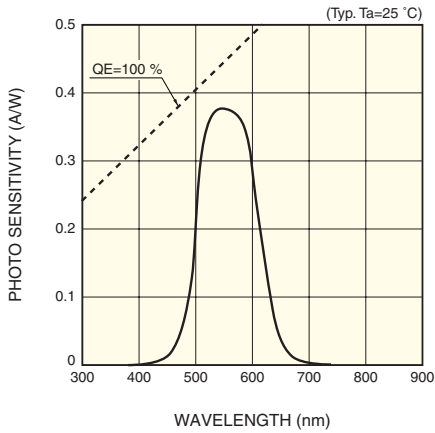

KSPDB0133EA

■ Spectral response (relative value)

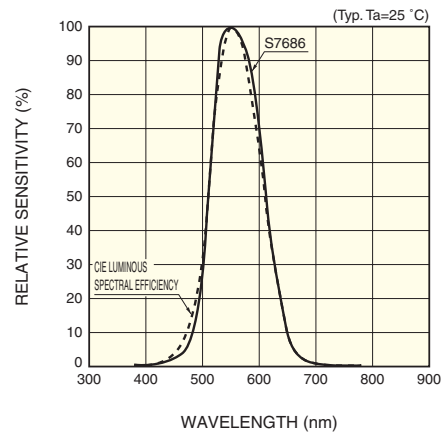

KSPDB0092EB

■ Dark current vs. reverse voltage

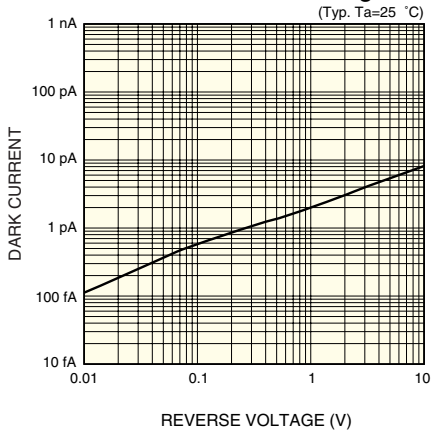

KSPDB0144EA

■ Terminal capacitance vs. reverse voltage

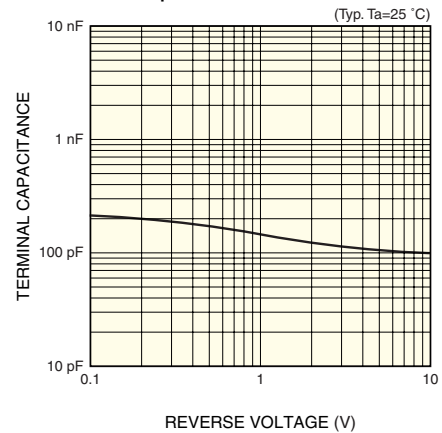

KSPDB0145EA

■ Dimensional outline (unit: mm, tolerance unless otherwise noted: ±0.15)

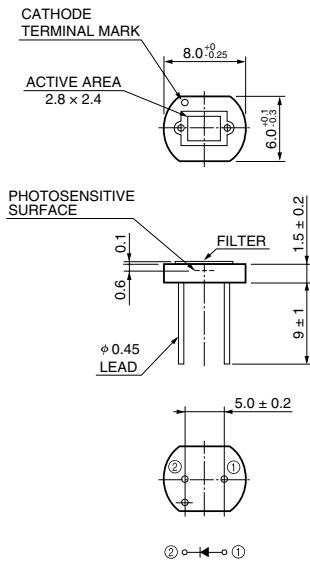

KSPDA0089EA

HAMAMATSU

Information furnished by HAMAMATSU is believed to be reliable. However, no responsibility is assumed for possible inaccuracies or omissions. Specifications are subject to change without notice. No patent rights are granted to any of the circuits described herein. ©2001 Hamamatsu Photonics K.K.

HAMAMATSU PHOTONICS K.K., Solid State Division

1126-1 Ichino-cho, Hamamatsu City, 435-8558 Japan, Telephone: (81) 053-434-3311, Fax: (81) 053-434-5184, <http://www.hamamatsu.com>

U.S.A.: Hamamatsu Corporation: 360 Foothill Road, P.O.Box 6910, Bridgewater, N.J. 08807-0910, U.S.A., Telephone: (1) 908-231-0960, Fax: (1) 908-231-1218

Germany: Hamamatsu Photonics Deutschland GmbH: Arzbergerstr. 10, D-82211 Herrsching am Ammersee, Germany, Telephone: (49) 08152-3750, Fax: (49) 08152-2658

France: Hamamatsu Photonics France S.A.R.L.: 8, Rue du Saule Trapu, Parc du Moulin de Massy, 91882 Massy Cedex, France, Telephone: 33-(1) 69 53 71 00, Fax: 33-(1) 69 53 71 10

United Kingdom: Hamamatsu Photonics UK Limited: 2 Howard Court, 10 Tewin Road, Welwyn Garden City, Hertfordshire AL7 1BW, United Kingdom, Telephone: (44) 1707-294888, Fax: (44) 1707-325777

North Europe: Hamamatsu Photonics Norden AB: Smidesvägen 12, SE-171 41 Solna, Sweden, Telephone: (46) 8-509-031-00, Fax: (46) 8-509-031-01

Italy: Hamamatsu Photonics Italia S.R.L.: Strada della Moia, 1/E, 20020 Arese, (Milano), Italy, Telephone: (39) 02-935-81-733, Fax: (39) 02-935-81-741