

**Surface Mount  
unidirectional and bidirectional  
Transient Voltage Suppressor Diodes**

**Unidirektionale und bidirektionale  
Spannungs-Begrenzer-Dioden  
für die Oberflächenmontage**

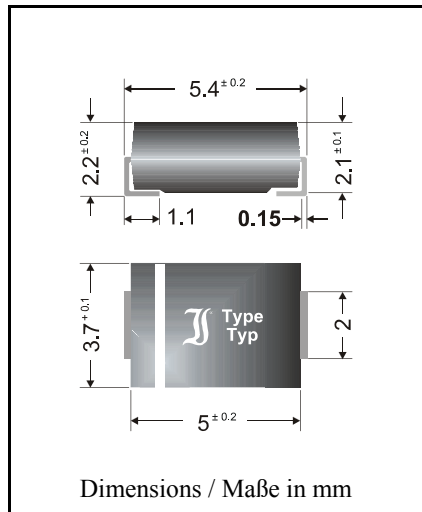

Pulse power dissipation – Impuls-Verlustleistung	600 W
Maximum stand-off voltage	6.5...170 V
Maximale Sperrspannung	
Plastic case	~ SMB
Kunststoffgehäuse	~ DO-214AA
Weight approx. – Gewicht ca.	0.1 g
Plastic material has UL classification 94V-0	
Gehäusematerial UL94V-0 klassifiziert	
Standard packaging taped and reeled	see page 18
Standard Lieferform gegurtet auf Rolle	siehe Seite 18

Suffix “C” or “CA” for bidirectional types

Suffix “C” oder “CA” für bidirektionale Typen

**Maximum ratings and Characteristics**

**Grenz- und Kennwerte**

Peak pulse power dissipation (10/1000 $\mu$ s waveform) Impuls-Verlustleistung (Strom-Impuls 10/1000 $\mu$ s)	$T_A = 25^\circ\text{C}$	$P_{PPM}$	600 W <sup>1)</sup>
Steady state power dissipation Verlustleistung im Dauerbetrieb	$T_A = 25^\circ\text{C}$	$P_{M(AV)}$	5 W <sup>2)</sup>
Peak forward surge current, 60 Hz half sine-wave Stoßstrom für eine 60 Hz Sinus-Halbwellen	$T_A = 25^\circ\text{C}$	$I_{FSM}$	100 A <sup>3)</sup>
Max. instantaneous forward voltage Augenblickswert der Durchlaßspannung	$I_F = 25\text{ A}$	$V_F$	< 3.0 V <sup>3)</sup>
Operating junction temperature – Sperrschichttemperatur Storage temperature – Lagerungstemperatur		$T_j$ $T_s$	- 50...+150°C - 50...+150°C
Thermal resistance junction to ambient air Wärmewiderstand Sperrschicht – umgebende Luft		$R_{thA}$	< 60 K/W <sup>2)</sup>
Thermal resistance junction to terminal Wärmewiderstand Sperrschicht – Anschluß		$R_{thT}$	< 15 K/W

<sup>1)</sup> Non-repetitive current pulse see curve  $I_{PPM} = f(t_r)$   
Höchstzulässiger Spitzenwert eines einmaligen Strom-Impulses, siehe Kurve  $I_{PPM} = f(t_r)$

<sup>2)</sup> Mounted on P.C. board with 50 mm<sup>2</sup> copper pads at each terminal  
Montage auf Leiterplatte mit 50 mm<sup>2</sup> Kupferbelag (Löt-pad) an jedem Anschluß

<sup>3)</sup> Unidirectional diodes only – nur für unidirektionale Dioden

**Maximum ratings**
**Grenzwerte**

Type Typ	Max. stand-off voltage Max. Sperrspannung at / bei $I_D$		Breakdown voltage at $I_T = 1$ mA Abbruch-Spannung bei $I_T = 1$ mA *) at / bei $I_T = 10$ mA		Max. clamping voltage Max. Begrenzer-Spannung at / bei $I_{PPM}$ (10/1000 $\mu$ s)	
	$V_{WM}$ [V]	$I_D$ [ $\mu$ A]	$V_{BR}$ min. [V]	$V_{BR}$ max. [V]	$V_C$ [V]	$I_{PPM}$ [A]
P6 SMBJ 6.5	6.5	500	7.2 *)	8.8 *)	12.3	48.8
P6 SMBJ 6.5A	6.5	500	7.2 *)	8.0 *)	11.2	53.6
P6 SMBJ 7.0	7.0	200	7.8 *)	9.5 *)	13.3	45.1
P6 SMBJ 7.0A	7.0	200	7.8 *)	8.7 *)	12.0	50.0
P6 SMBJ 7.5	7.5	100	8.3	10.1	14.3	42.0
P6 SMBJ 7.5A	7.5	100	8.3	9.2	12.9	46.5
P6 SMBJ 8.0	8.0	50	8.9	10.9	15.0	40.0
P6 SMBJ 8.0A	8.0	50	8.9	9.9	13.6	44.1
P6 SMBJ 8.5	8.5	10	9.4	11.5	15.9	37.7
P6 SMBJ 8.5A	8.5	10	9.4	10.4	14.4	41.7
P6 SMBJ 9.0	9.0	5	10.0	12.2	16.9	35.5
P6 SMBJ 9.0A	9.0	5	10.0	11.1	15.4	39.0
P6 SMBJ 10	10	5	11.1	13.5	18.8	31.9
P6 SMBJ 10A	10	5	11.1	12.3	17.0	35.3
P6 SMBJ 11	11	5	12.2	14.9	20.1	29.9
P6 SMBJ 11A	11	5	12.2	13.5	18.2	33.0
P6 SMBJ 12	12	5	13.3	16.2	22.0	27.3
P6 SMBJ 12A	12	5	13.3	14.8	19.9	30.2
P6 SMBJ 13	13	5	14.4	17.6	23.8	25.2
P6 SMBJ 13A	13	5	14.4	16.0	21.5	27.9
P6 SMBJ 14	14	5	15.6	19.0	25.8	23.3
P6 SMBJ 14A	14	5	15.6	17.3	23.2	25.9
P6 SMBJ 15	15	5	16.7	20.4	26.9	22.3
P6 SMBJ 15A	15	5	16.7	18.6	24.4	24.6
P6 SMBJ 16	16	5	17.8	21.7	28.8	20.8
P6 SMBJ 16A	16	5	17.8	19.8	26.0	23.1
P6 SMBJ 17	17	5	18.9	23.1	30.5	19.7
P6 SMBJ 17A	17	5	18.9	21.0	27.6	21.7
P6 SMBJ 18	18	5	20.0	24.4	32.2	18.6
P6 SMBJ 18A	18	5	20.0	22.2	29.2	20.5
P6 SMBJ 20	20	5	22.2	27.1	35.8	16.8
P6 SMBJ 20A	20	5	22.2	24.6	32.4	18.5
P6 SMBJ 22	22	5	24.4	29.8	39.4	15.2
P6 SMBJ 22A	22	5	24.4	27.1	35.5	16.9
P6 SMBJ 24	24	5	26.7	32.6	43.0	14.0
P6 SMBJ 24A	24	5	26.7	29.6	38.9	15.4
P6 SMBJ 26	26	5	28.9	35.3	46.6	12.9
P6 SMBJ 26A	26	5	28.9	32.1	42.1	14.3
P6 SMBJ 28	28	5	31.1	37.9	50.0	12.0
P6 SMBJ 28A	28	5	31.1	34.5	45.4	13.2
P6 SMBJ 30	30	5	33.3	40.1	53.5	11.2
P6 SMBJ 30A	30	5	33.3	36.9	48.4	12.4
P6 SMBJ 33	33	5	36.7	44.8	59.0	10.2
P6 SMBJ 33A	33	5	36.7	40.7	53.3	11.3

## Maximum ratings

## Grenzwerte

Type Typ	Max. stand-off voltage Max. Sperrspannung at / bei $I_D$		Breakdown voltage at $I_T = 1$ mA Abbruch-Spannung bei $I_T = 1$ mA		Max. clamping voltage Max. Begrenzer-Spannung at / bei $I_{PPM}$ (10/1000 $\mu$ s)	
	$V_{WM}$ [V]	$I_D$ [ $\mu$ A]	$V_{BR}$ min. [V]	$V_{BR}$ max. [V]	$V_C$ [V]	$I_{PPM}$ [A]
P6 SMBJ 36	36	5	40.0	48.8	64.3	9.3
P6 SMBJ 36A	36	5	40.0	44.4	58.1	10.3
P6 SMBJ 40	40	5	44.4	54.2	71.4	8.4
P6 SMBJ 40A	40	5	44.4	49.3	64.5	9.3
P6 SMBJ 43	43	5	47.8	58.3	76.7	7.8
P6 SMBJ 43A	43	5	47.8	53.1	69.4	8.6
P6 SMBJ 45	45	5	50.0	61.0	80.3	7.5
P6 SMBJ 45A	45	5	50.0	55.5	72.7	8.3
P6 SMBJ 48	48	5	53.3	65.0	85.5	7.0
P6 SMBJ 48A	48	5	53.3	59.2	77.4	7.8
P6 SMBJ 51	51	5	56.7	69.2	91.1	6.6
P6 SMBJ 51A	51	5	56.7	62.9	82.4	7.3
P6 SMBJ 54	54	5	60.0	73.2	96.3	6.2
P6 SMBJ 54A	54	5	60.0	66.6	87.1	6.9
P6 SMBJ 58	58	5	64.4	78.6	103	5.8
P6 SMBJ 58A	58	5	64.4	71.5	93.6	6.4
P6 SMBJ 60	60	5	66.7	81.4	107	5.6
P6 SMBJ 60A	60	5	66.7	74.0	96.8	6.2
P6 SMBJ 64	64	5	71.1	86.7	114	5.3
P6 SMBJ 64A	64	5	71.1	78.9	103	5.8
P6 SMBJ 70	70	5	77.8	94.9	125	4.8
P6 SMBJ 70A	70	5	77.8	86.4	113	5.3
P6 SMBJ 75	75	5	83.3	102	134	4.5
P6 SMBJ 75A	75	5	83.3	92.5	121	5.0
P6 SMBJ 78	78	5	86.7	106	139	4.3
P6 SMBJ 78A	78	5	86.7	96.2	126	4.8
P6 SMBJ 85	85	5	94.4	115	151	4.0
P6 SMBJ 85A	85	5	94.4	105	137	4.4
P6 SMBJ 90	90	5	100	122	160	3.8
P6 SMBJ 90A	90	5	100	111	146	4.1
P6 SMBJ 100	100	5	111	135	179	3.4
P6 SMBJ 100A	100	5	111	123	162	3.7
P6 SMBJ 110	110	5	122	149	196	3.1
P6 SMBJ 110A	110	5	122	135	177	3.4
P6 SMBJ 120	120	5	133	162	214	2.8
P6 SMBJ 120A	120	5	133	148	193	3.1
P6 SMBJ 130	130	5	144	176	231	2.6
P6 SMBJ 130A	130	5	144	160	209	2.9
P6 SMBJ 150	150	5	167	204	268	2.2
P6 SMBJ 150A	150	5	167	185	243	2.5
P6 SMBJ 160	160	5	178	217	287	2.1
P6 SMBJ 160A	160	5	178	198	259	2.3
P6 SMBJ 170	170	5	189	231	304	2.0
P6 SMBJ 170A	170	5	189	210	275	2.2

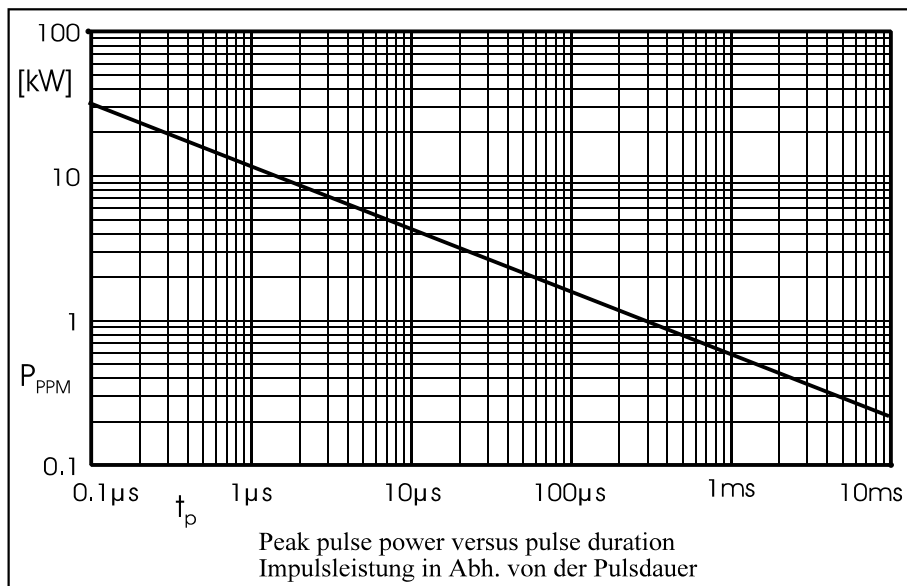
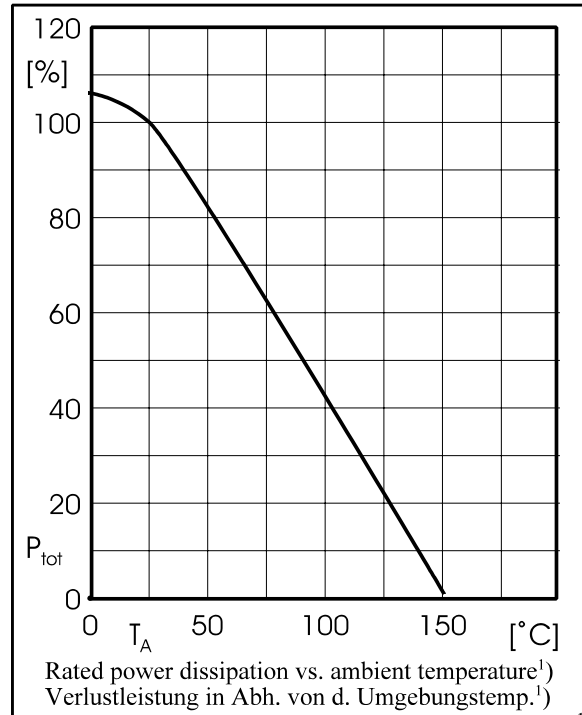
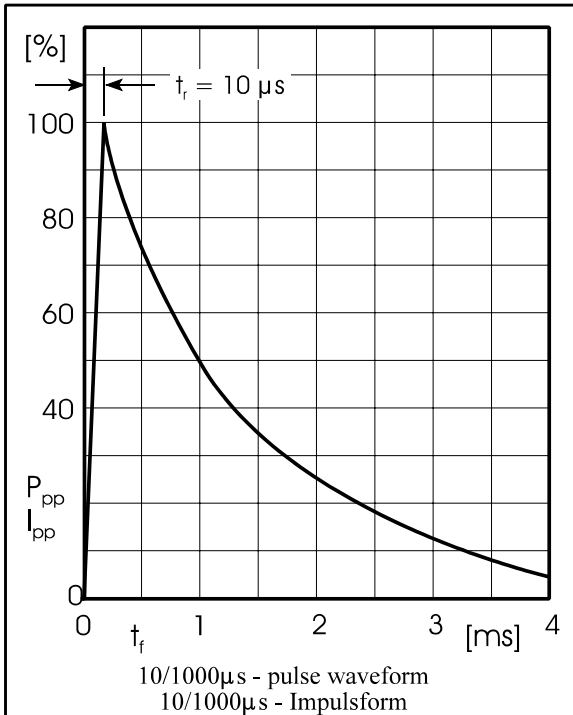

For bidirectional types (suffix “C” or “CA”) electrical characteristics apply in both directions  
Für bidirektionale Dioden (Suffix “C” oder “CA”) gelten die el. Werte in beiden Richtungen

<sup>1)</sup> Mounted on P.C. board with 50 mm<sup>2</sup> copper pads at each terminal  
Montage auf Leiterplatte mit 50 mm<sup>2</sup> Kupferbelag (Lötpad) an jedem Anschluß