

FEATURES

- * 1.8 INCH (46.7 mm) DIGIT HEIGHT.
- * LOW POWER REQUIREMENT.
- * CONTINUOUS UNIFORM SEGMENTS.
- * EXCELLENT CHARACTER APPEARANCE.
- * WIDE VIEWING ANGLE.
- * HIGH CONTRAST.
- * HIGH BRIGHTNESS.
- * FULL FEATURE SELECTABLE.
- * FREQUENCY DISPLAY.
- * DESIGNED FOR CLOCK INDICATION, TIMER FREQUENCY COUNTER, ..., ECT.

DESCRIPTION

The LTC-18501A1G-2 is a 1.8 inch (46.7 mm) digit height clock display. This display utilizes green LED chips, which are made from GaP on a transparent GaP substrate, and a green face film on it.

DEVICE

PART NO.	DESCRIPTION
GREEN	Common Cathode
LTC-18501A1G-2	

PACKAGE DIMENSIONS

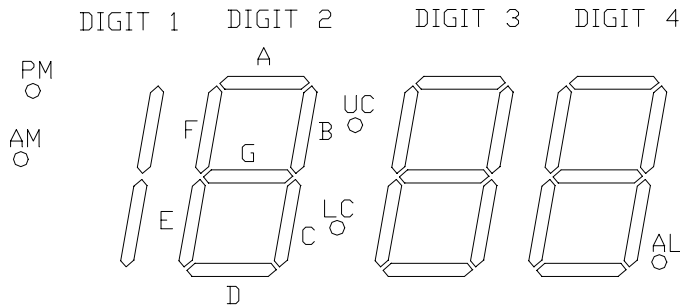
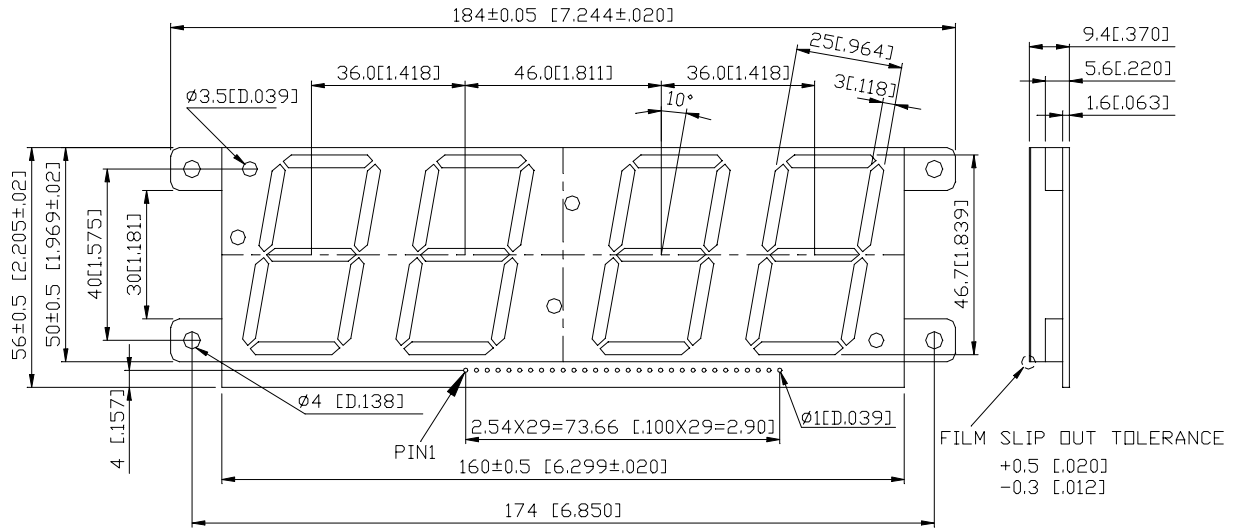

NOTES: All dimensions are in millimeters. Tolerance is ± 0.25 -mm (0.01") unless otherwise noted.

INTERNAL CIRCUIT DIAGRAM

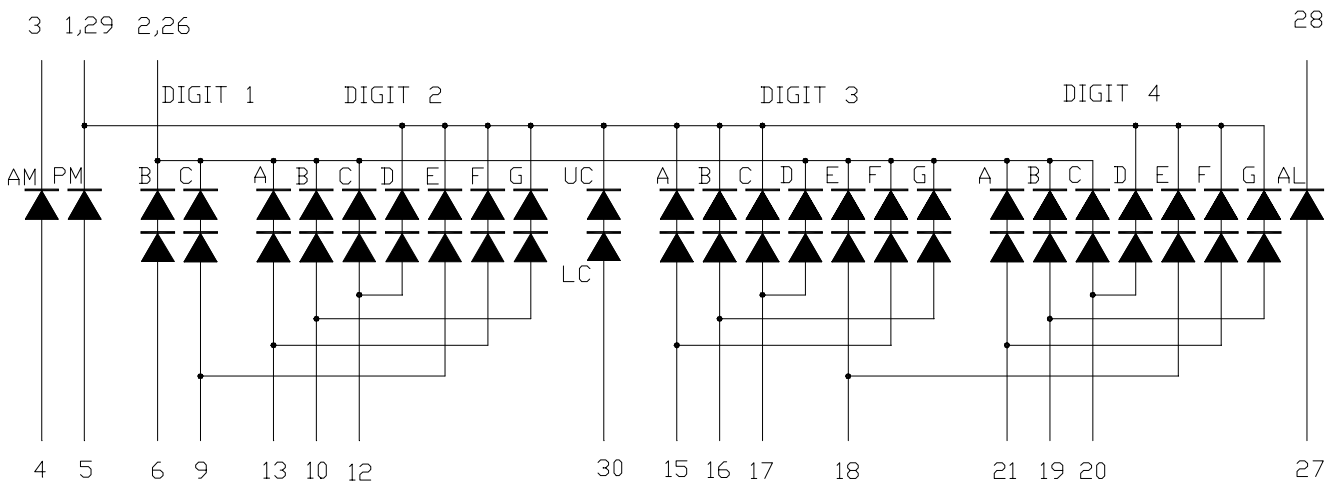

PIN CONNECTION

NO	CONNECTION	NO	CONNECTION
1	COMMON CATHODE 1	16	DIGIT 3 ANODE B, DIGIT 3 ANODE G
2	COMMON CATHODE 2	17	DIGIT 3 ANODE C, DIGIT 3 ANODE D
3	CATHODE AM	18	DIGIT 3 ANODE E, DIGIT 4 ANODE E
4	ANODE AM	19	DIGIT 4 ANODE B, DIGIT 4 ANODE G
5	ANODE PM	20	DIGIT 4 ANODE C, DIGIT 4 ANODE D
6	DIGIT 1 ANODE B	21	DIGIT 4 ANODE A, DIGIT 4 ANODE F
7	NO CONNECTION	22	NO CONNECTION
8	NO CONNECTION	23	NO CONNECTION
9	DIGIT 2 ANODE E, DIGIT 1 ANODE C	24	NO CONNECTION
10	DIGIT 2 ANODE B, DIGIT 2 ANODE G	25	NO CONNECTION
11	NO USE	26	COMMON CATHODE 2
12	DIGIT 2 ANODE C, DIGIT 2 ANODE D	27	ANODE AL
13	DIGIT 2 ANODE A, DIGIT 2 ANODE F	28	CATHODE AL
14	NO USE	29	COMMON CATHODE 1
15	DIGIT 3 ANODE A, DIGIT 3 ANODE F	30	ANODE UC, ANODE LC

ABSOLUTE MAXIMUM RATING AT T_A=25°C

PARAMETER	MAXIMUM RATING	UNIT
Power Dissipation Per Segment	120(75)	mW
Peak Forward Current Per Segment (1/10 Duty Cycle, 0.1ms Pulse Width)	100	mA
Continuous Forward Current Per Segment	25	mA
Forward Voltage, Per Segment	0.33	mA/°C
Reverse Voltage Per Segment	10(5)	V
Operating Temperature Range	-25°C to +65°C	
Storage Temperature Range	-25°C to +65°C	
Solder Temperature: 3.5mm Below PCB.back side for 3sec. at 260°C		

ELECTRICAL / OPTICAL CHARACTERISTICS AT T_A=25°C

PARAMETER	SYMBOL	MIN.	TYP.	MAX.	UNIT	TEST CONDITION
Average Luminous Intensity	I _v	500	1200		μcd	I _F =10mA
Peak Emission Wavelength	λ _p		565		nm	I _F =20mA
Spectral Line Half-Width	Δλ		30		nm	I _F =20mA
Dominant Wavelength	λ _d		569		nm	I _F =20mA
Forward Voltage Per Segment	V _F		4.2 (2.1)	5.2 (2.6)	V	I _F =20mA
Reverse Current Per Segment	I _R			100	μA	V _R =10V
Luminous Intensity Matching Ratio	I _v -m			2:1		I _F =10mA

Note: Luminous intensity is measured with a light sensor and filter combination that approximates the CIE (Commision Internationale De L'Eclariage) eye-response curve.

TYPICAL ELECTRICAL / OPTICAL CHARACTERISTIC CURVES

(25°C Ambient Temperature Unless Otherwise Noted)

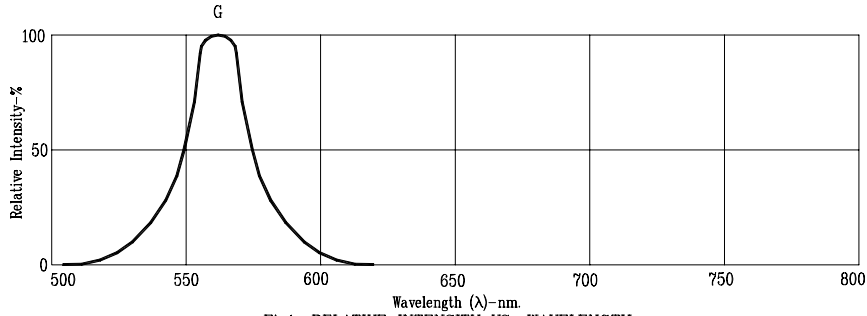

Fig1. RELATIVE INTENSITY VS. WAVELENGTH

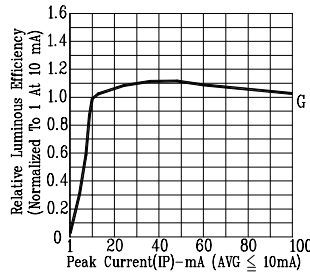

Fig2. RELATIVE LUMINOUS EFFICIENCY (LUMINOUS INTENSITY PER UNIT CURRENT) VS. PEAK CURRENT (REFRESH RATE 1KHz)

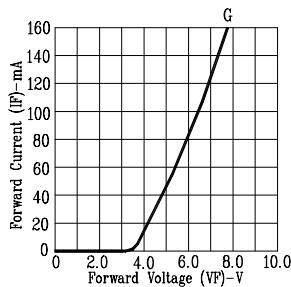

Fig3. FORWARD CURRENT VS. FORWARD VOLTAGE

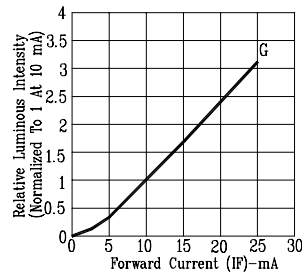

Fig4. RELATIVE LUMINOUS INTENSITY VS. FORWARD CURRENT

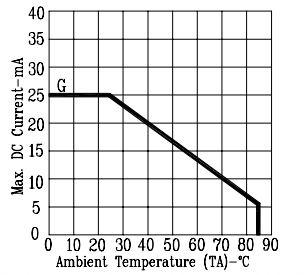

Fig5. MAX ALLOWABLE DC CURRENT VS. AMBIENT TEMPERATURE.

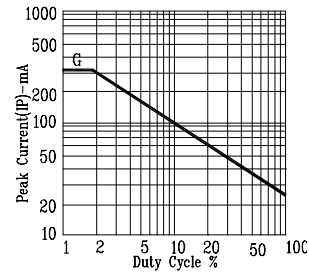

Fig6. MAX PEAK CURRENT VS. DUTY CYCLE % (REFRESH RATE 1KHz)

NOTE: G=GREEN