

# HAT1072H

Silicon P Channel Power MOS FET  
Power Switching

## HITACHI

ADE-208-1534E (Z)

6th. Edition  
May 2002

### Features

- Capable of -4.5 V gate drive
- Low drive current
- High density mounting
- Low on-resistance  
 $R_{DS(on)} = 3.6 \text{ m}\Omega$  typ (at  $V_{GS} = -10 \text{ V}$ )

### Outline

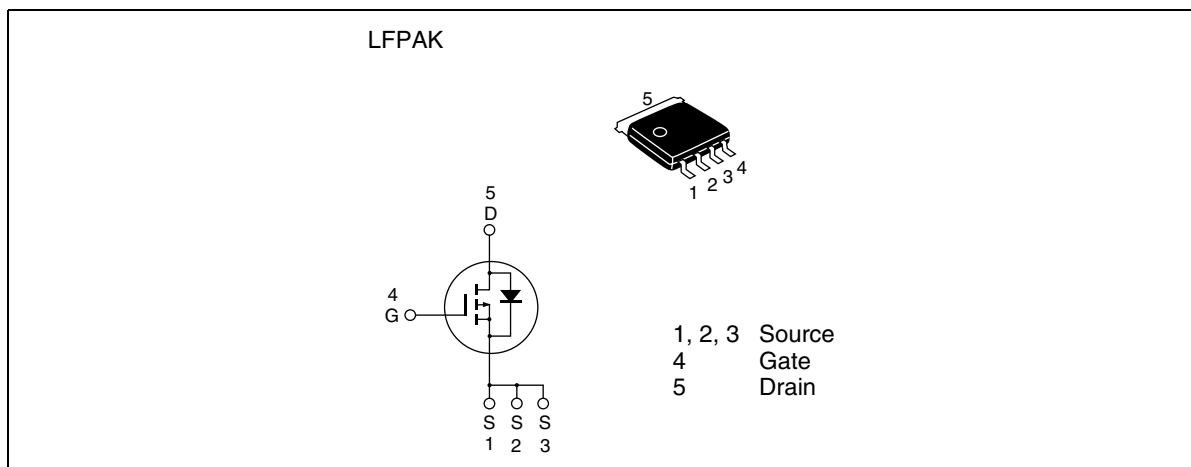

## Absolute Maximum Ratings

( $T_a = 25^\circ\text{C}$ )

Item	Symbol	Ratings	Unit
Drain to source voltage	$V_{DSS}$	-30	V
Gate to source voltage	$V_{GSS}$	-20/+10	V
Drain current	$I_D$	-40	A
Drain peak current	$I_{D(pulse)}$ <sup>Note1</sup>	-160	A
Body-drain diode reverse drain current	$I_{DR}$	-40	A
Channel dissipation	$P_{ch}$ <sup>Note2</sup>	30	W
Channel temperature	$T_{ch}$	150	$^\circ\text{C}$
Storage temperature	$T_{stg}$	- 55 to + 150	$^\circ\text{C}$

Notes: 1.  $PW \leq 10 \mu\text{s}$ , duty cycle  $\leq 1\%$

2.  $T_c=25^\circ\text{C}$

## Electrical Characteristics

( $T_a = 25^\circ\text{C}$ )

Item	Symbol	Min	Typ	Max	Unit	Test Conditions
Drain to source breakdown voltage	$V_{(BR)DSS}$	-30	—	—	V	$I_D = -10\text{ mA}$ , $V_{GS} = 0$
Gate to source leak current	$I_{GSS}$	—	—	$\pm 0.1$	$\mu\text{A}$	$V_{GS} = -20, +10\text{ V}$ , $V_{DS} = 0$
Zero gate voltage drain current	$I_{DSS}$	—	—	-1	$\mu\text{A}$	$V_{DS} = -30\text{ V}$ , $V_{GS} = 0$
Gate to source cutoff voltage	$V_{GS(off)}$	-0.5	—	-2.0	V	$V_{DS} = -10\text{ V}$ , $I_D = -1\text{ mA}$
Static drain to source on state resistance	$R_{DS(on)}$	—	3.6	4.5	$\text{m}\Omega$	$I_D = -20\text{ A}$ , $V_{GS} = -10\text{ V}$ <sup>Note3</sup>
	$R_{DS(on)}$	—	5.3	7.7	$\text{m}\Omega$	$I_D = -20\text{ A}$ , $V_{GS} = -4.5\text{ V}$ <sup>Note3</sup>
Forward transfer admittance	$ y_{fs} $	36	60	—	S	$I_D = -20\text{ A}$ , $V_{DS} = -10\text{ V}$ <sup>Note3</sup>
Input capacitance	$C_{iss}$	—	9500	—	pF	$V_{DS} = -10\text{ V}$
Output capacitance	$C_{oss}$	—	1300	—	pF	$V_{GS} = 0$
Reverse transfer capacitance	$C_{rss}$	—	700	—	pF	$f = 1\text{ MHz}$
Total gate charge	$Q_g$	—	155	—	nc	$V_{DD} = -10\text{ V}$
Gate to source charge	$Q_{gs}$	—	28	—	nc	$V_{GS} = -10\text{ V}$
Gate to drain charge	$Q_{gd}$	—	26	—	nc	$I_D = -40\text{ A}$
Turn-on delay time	$t_{d(on)}$	—	28	—	ns	$V_{GS} = -10\text{ V}$ , $I_D = -20\text{ A}$
Rise time	$t_r$	—	60	—	ns	$V_{DD} \cong -10\text{ V}$
Turn-off delay time	$t_{d(off)}$	—	305	—	ns	$R_L = 0.5\ \Omega$
Fall time	$t_f$	—	140	—	ns	$R_g = 4.7\ \Omega$
Body-drain diode forward voltage	$V_{DF}$	—	0.87	1.14	V	$I_F = -40\text{ A}$ , $V_{GS} = 0$ <sup>Note3</sup>
Body-drain diode reverse recovery time	$t_{rr}$	—	110	—	ns	$I_F = -40\text{ A}$ , $V_{GS} = 0$ $diF/dt = 100\text{ A}/\mu\text{s}$

Notes: 3. Pulse test

## Main Characteristics

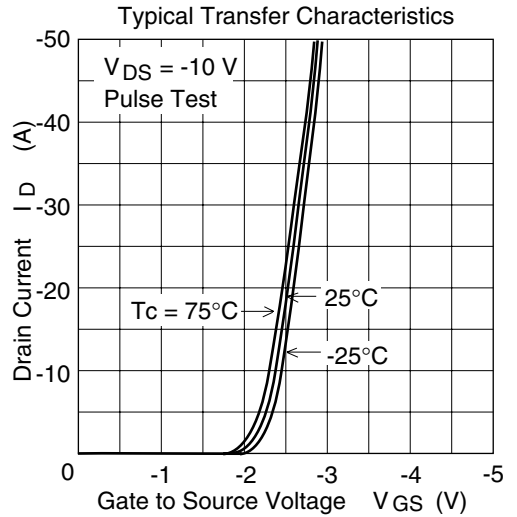
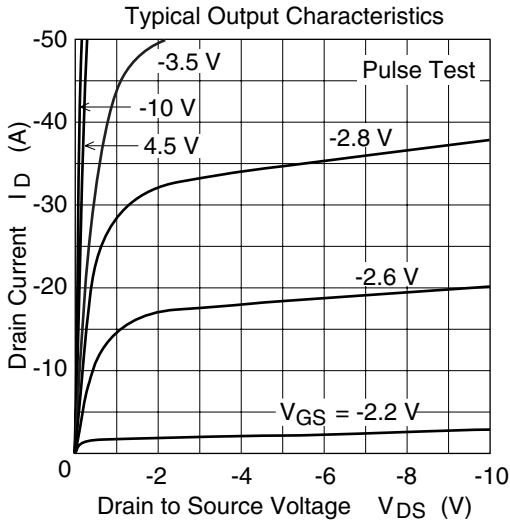
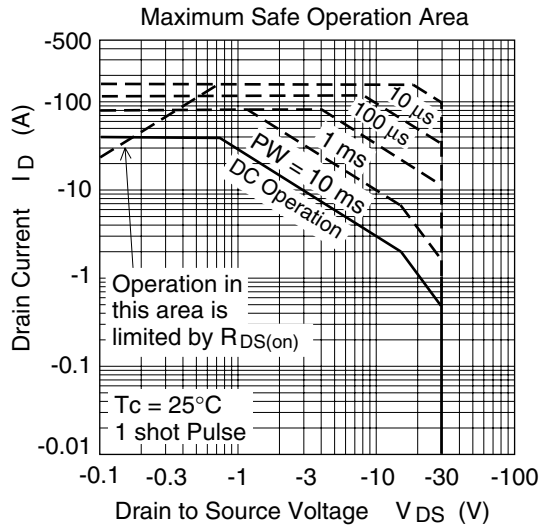
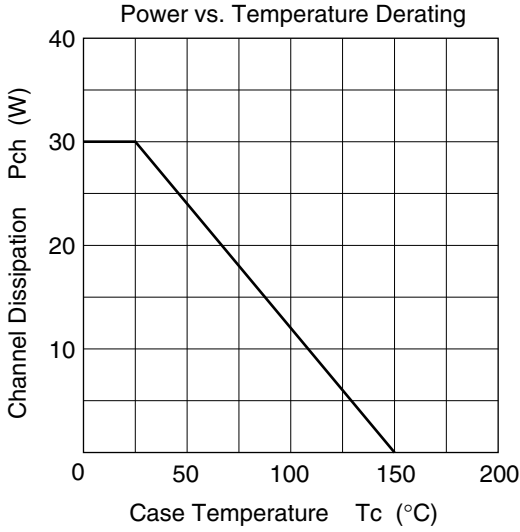

Drain to Source Saturation Voltage vs. Gate to Source Voltage

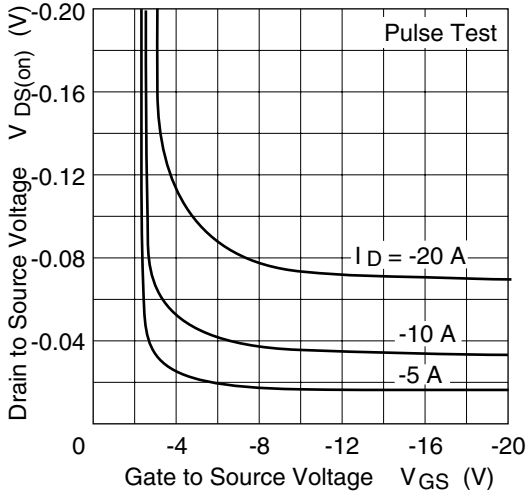

Static Drain to Source on State Resistance vs. Drain Current

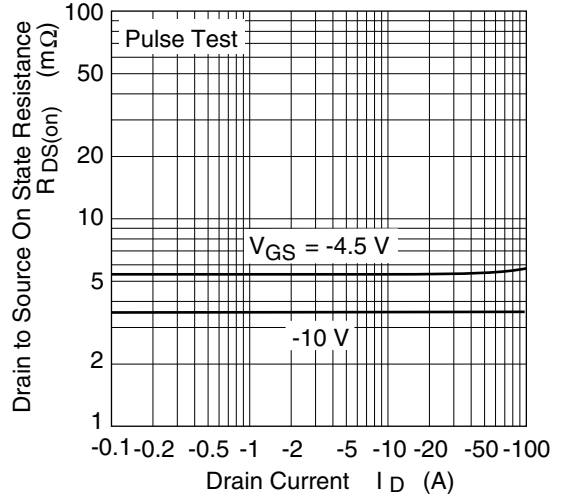

Static Drain to Source on State Resistance vs. Temperature

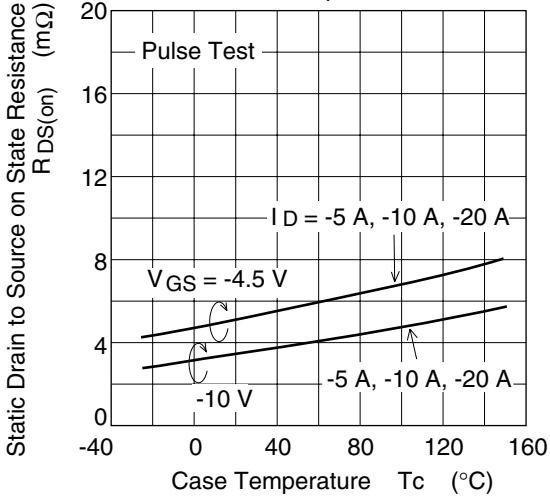

Forward Transfer Admittance vs. Drain Current

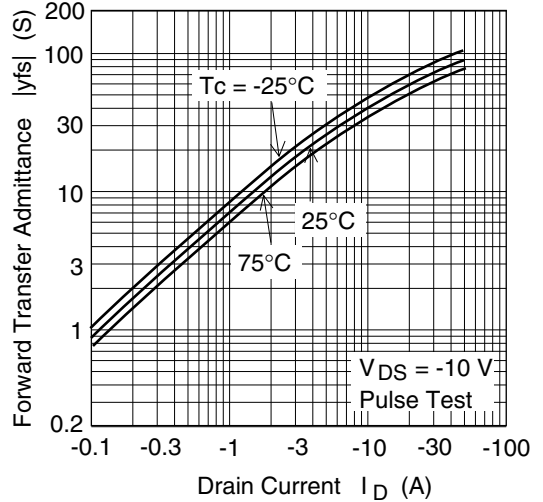

Body-Drain Diode Reverse Recovery Time

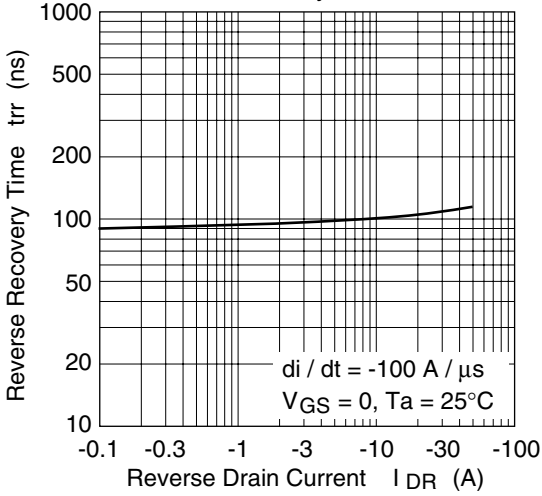

Typical Capacitance vs. Drain to Source Voltage

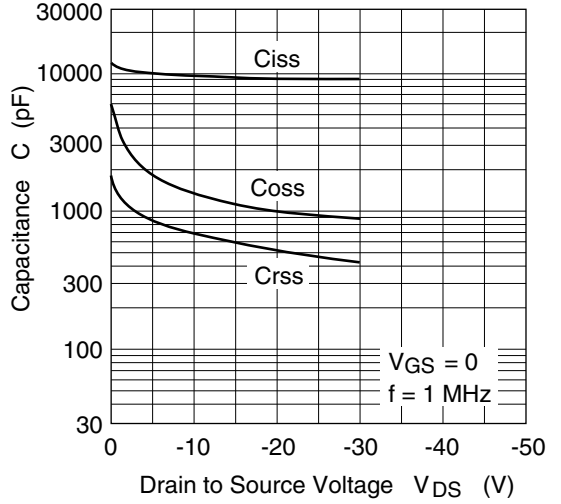

Dynamic Input Characteristics

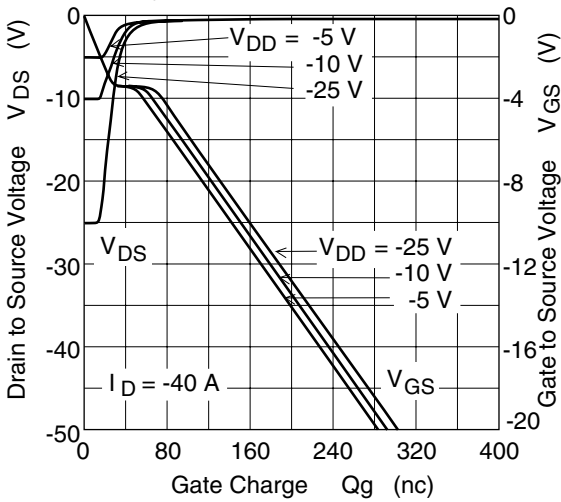

Switching Characteristics

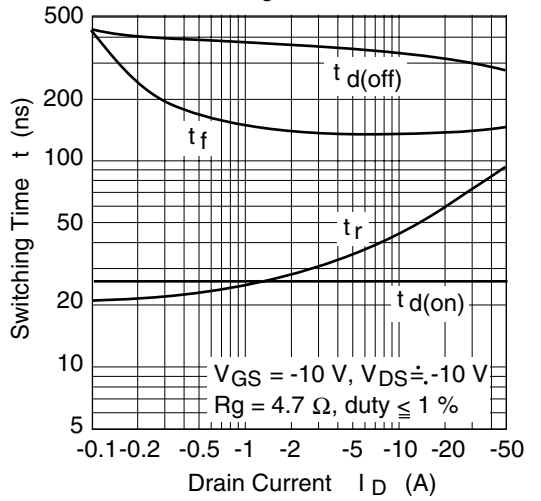

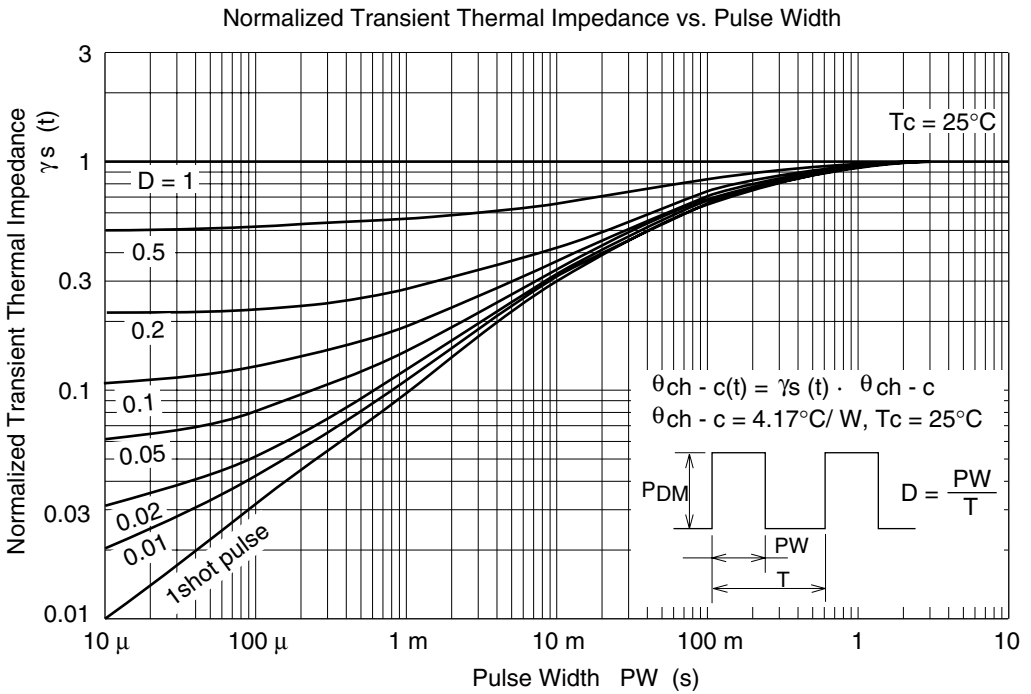
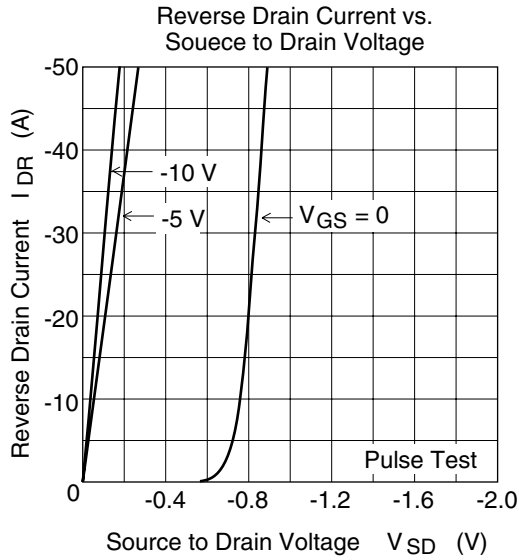

Switching Time Test Circuit

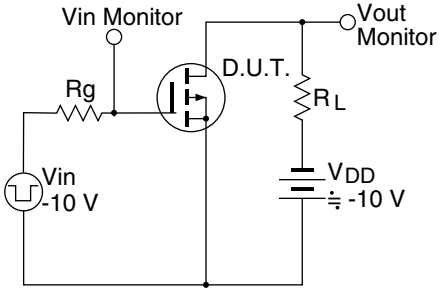

Switching Time Waveform

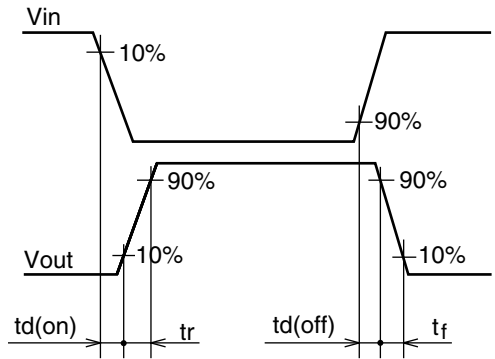



Package Dimensions

As of January, 2002

Unit: mm

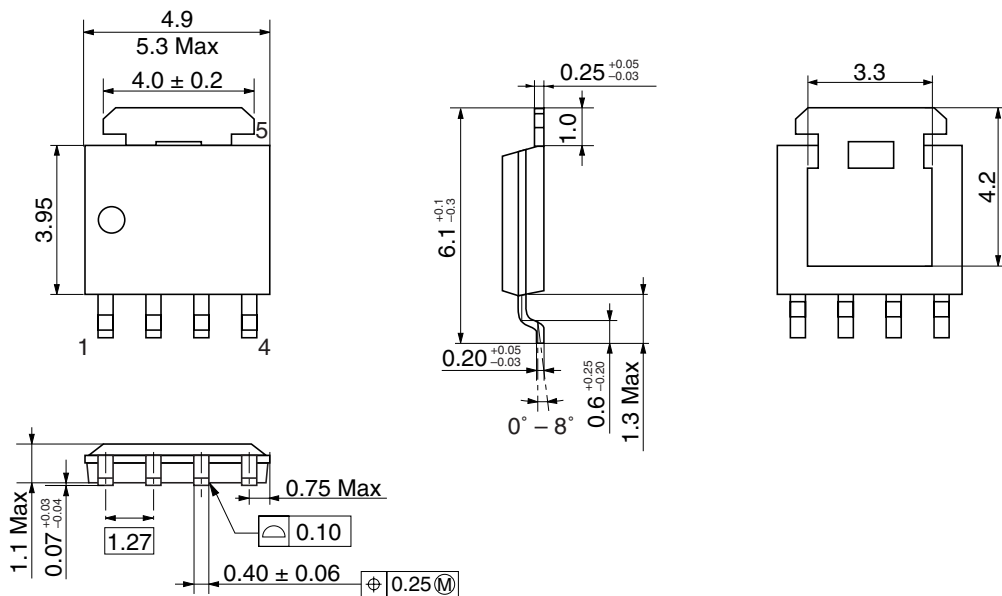

Hitachi Code	LFPAK
JEDEC	—
JEITA	—
Mass (reference value)	0.080 g

## Disclaimer

1. Hitachi neither warrants nor grants licenses of any rights of Hitachi's or any third party's patent, copyright, trademark, or other intellectual property rights for information contained in this document. Hitachi bears no responsibility for problems that may arise with third party's rights, including intellectual property rights, in connection with use of the information contained in this document.
2. Products and product specifications may be subject to change without notice. Confirm that you have received the latest product standards or specifications before final design, purchase or use.
3. Hitachi makes every attempt to ensure that its products are of high quality and reliability. However, contact Hitachi's sales office before using the product in an application that demands especially high quality and reliability or where its failure or malfunction may directly threaten human life or cause risk of bodily injury, such as aerospace, aeronautics, nuclear power, combustion control, transportation, traffic, safety equipment or medical equipment for life support.
4. Design your application so that the product is used within the ranges guaranteed by Hitachi particularly for maximum rating, operating supply voltage range, heat radiation characteristics, installation conditions and other characteristics. Hitachi bears no responsibility for failure or damage when used beyond the guaranteed ranges. Even within the guaranteed ranges, consider normally foreseeable failure rates or failure modes in semiconductor devices and employ systemic measures such as fail-safes, so that the equipment incorporating Hitachi product does not cause bodily injury, fire or other consequential damage due to operation of the Hitachi product.
5. This product is not designed to be radiation resistant.
6. No one is permitted to reproduce or duplicate, in any form, the whole or part of this document without written approval from Hitachi.
7. Contact Hitachi's sales office for any questions regarding this document or Hitachi semiconductor products.

## Sales Offices

# HITACHI

### Hitachi, Ltd.

Semiconductor & Integrated Circuits  
Nippon Bldg., 2-6-2, Ohte-machi, Chiyoda-ku, Tokyo 100-0004, Japan  
Tel: (03) 3270-2111 Fax: (03) 3270-5109

URL      NorthAmerica      : <http://semiconductor.hitachi.com/>  
             Europe                : <http://www.hitachi-eu.com/hel/ecg>  
             Asia                        : <http://sicapac.hitachi-asia.com>  
             Japan                        : <http://www.hitachi.co.jp/Sicd/indx.htm>

### For further information write to:

Hitachi Semiconductor (America) Inc. 179 East Tasman Drive San Jose, CA 95134 Tel: <1>(408) 433-1990 Fax: <1>(408) 433-0223	Hitachi Europe Ltd. Electronic Components Group Whitebrook Park Lower Cookham Road Maidenhead Berkshire SL6 8YA, United Kingdom Tel: <44> (1628) 585000 Fax: <44> (1628) 585200
	Hitachi Europe GmbH Electronic Components Group Domacher StraÙe 3 D-85622 Feldkirchen, Munich Germany Tel: <49> (89) 9 9180-0 Fax: <49> (89) 9 29 30 00

Hitachi Asia Ltd.  
Hitachi Tower  
16 Collyer Quay #20-00  
Singapore 049318  
Tel : <65>-538-6533/538-8577  
Fax : <65>-538-6933/538-3877  
URL : <http://www.hitachi.com.sg>

Hitachi Asia Ltd.  
(Taipei Branch Office)  
4/F, No. 167, Tun Hwa North Road  
Hung-Kuo Building  
Taipei (105), Taiwan  
Tel : <886>-(2)-2718-3666  
Fax : <886>-(2)-2718-8180  
Telex : 23222 HAS-TP  
URL : <http://www.hitachi.com.tw>

Hitachi Asia (Hong Kong) Ltd.  
Group III (Electronic Components)  
7/F., North Tower  
World Finance Centre,  
Harbour City, Canton Road  
Tsim Sha Tsui, Kowloon  
Hong Kong  
Tel : <852>-(2)-735-9218  
Fax : <852>-(2)-730-0281  
URL : <http://semiconductor.hitachi.com.hk>

Copyright © Hitachi, Ltd., 2001. All rights reserved. Printed in Japan.  
Colophon 4.0