



EVERLIGHT ELECTRONICS CO.,LTD.

Device Number : DDD-516-004 REV: 1.3

0.5" Dual Digit Displays

MODEL NO : ELD-516EWA ECN : Page: 1/5

■ Features :

- Industrial standard size.
- Low power consumption.
- Categorized for luminous intensity.

■ Applications:

- Audio equipment
- Instrument panels
- Digital read out display

■ Descriptions :

- The ELD-516 series is a large 12.7mm (0.5")high seven segment display designed for viewing distances up to 7 meters.
- These displays provide excellent reliability in bright ambient light.
- These devices are made with white segments and gray surface.

PART NO	Chip		C.C. or C.A.
	Material	Emitted Color	
ELD-516EWA	GaAsP/GaP	Orange	C.A.

OFFICE : NO. 25,Lane 76,Sec.3, Chung Yang Rd., Tucheng 236, Taipei, Taiwan, R.O.C.

TEL : 886-2-2267-2000,2267-9936

FAX : 886-2-2267-6244,22676189,22676306

<http://www.everlight.com>



0.5" Dual Digit Displays

MODEL NO : ELD-516EWA ECN : _____ Page: 2/5

Package Dimensions:

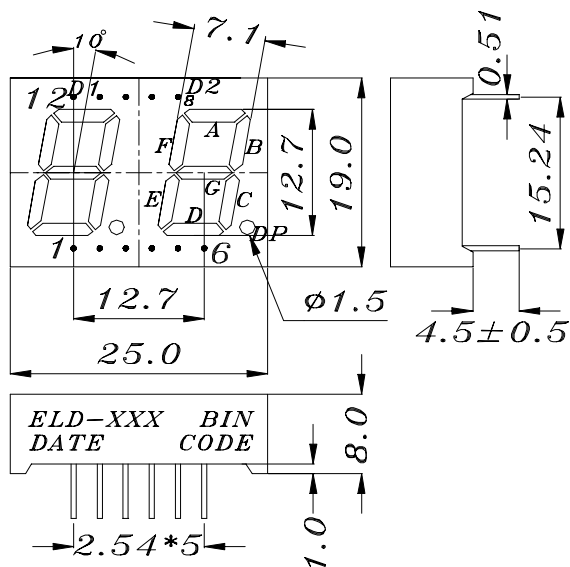

- COMMON ANODE**
- 1 CATHODE E
 - 2 CATHODE G
 - 3 COMMON ANODE DIG.1
 - 4 CATHODE DP1
 - 5 COMMON ANODE DIG.2
 - 6 CATHODE DP2
 - 7 NO PIN
 - 8 CATHODE A
 - 9 CATHODE D
 - 10 CATHODE B
 - 11 CATHODE C
 - 12 CATHODE F

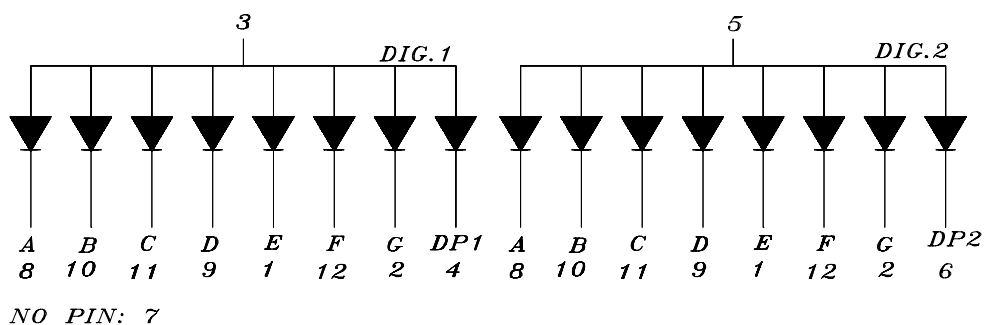

Notes:

1. All dimensions are in millimeters, tolerance is 0.25mm unless otherwise noted.
 2. Above specification may be changed without notice.
- Supplier will reserve authority on material change for above specification.

Device Number : DDD-516-004 REV: 1.3

0.5" Dual Digit Displays

MODEL NO : ELD-516EWA ECN : _____ Page: 3/5

■ Absolute maximum ratings at Ta = 25°C :

Parameter	Symbol	Rating	Unit
Reverse Voltage	Vr	5	V
Forward Current	If	30	mA
Operating Temperature	Topr	-40 to +85	°C
Storage Temperature	Tstg	-40 to +100	°C
Soldering Temperature	Tsol	260 ± 5	°C
Power Dissipation	Pd	100	mW
Peak Forward Current(Duty 1/10 @ 1KHZ)	If(Peak)	160	mA

■ Electronic optical characteristics :

Parameter		Symbol	MIN.	TYP.	MAX.	Unit	Condition
Luminous Intensity	Per segment	Iv	1.4	2.0	----	mcd	If=10mA
	Per decimal point		0.45	1.05	----	mcd	If=10mA
Peak Wavelength		λp	----	635	----	nm	If=20mA
Dominant Wavelength		λd	----	625	----	nm	If=20mA
Spectrum Radiation Bandwidth		$\Delta \lambda$	----	45	----	nm	If=20mA
Forward Voltage		Vf	1.7	2.0	2.4	V	If=20mA
Reverse Current		Ir	----	----	10	μA	Vr=5V



EVERLIGHT ELECTRONICS CO.,LTD.

Device Number : DDD-516-004 REV: 1.3

0.5" Dual Digit Displays

MODEL NO : ELD-516EWA ECN : _____ Page: 4/5

■ Reliability test items and conditions:					
NO	Item	Test Conditions	Test Hours/Cycle	Sample Size	Ac/Re
1	Solder Heat	TEMP : 260°C ± 5 °C	5 SEC	76 PCS	0/1
2	Temperature Cycle	H : +85°C 30min ∫ 5 min L : -55°C 30min	50 CYCLE	76 PCS	0/1
3	Thermal Shock	H : +100°C 5min ∫ 10 sec L : -10°C 5min	50 CYCLE	76 PCS	0/1
4	High Temperature Storage	TEMP : 100°C	1000 HRS	76 PCS	0/1
5	Low Temperature Storage	TEMP : -55°C	1000 HRS	76 PCS	0/1
6	DC Operating Life	If = 10 mA	1000 HRS	76 PCS	0/1
7	High Temperature / High Humidity	85°C / 85% RH	1000 HRS	76 PCS	0/1

