

PCF8563

Real-time clock/calendar

16 April 1999

Product specification

1. General description

The PCF8563 is a CMOS real-time clock/calendar optimized for low power consumption. A programmable clock output, interrupt output and voltage-low detector are also provided. All address and data are transferred serially via a two-line bidirectional I²C-bus. Maximum bus speed is 400 kbits/s. The built-in word address register is incremented automatically after each written or read data byte.

2. Features

- Provides year, month, day, weekday, hours, minutes and seconds based on 32.768 kHz quartz crystal
- Century flag
- Wide operating supply voltage range: 1.0 to 5.5 V
- Low back-up current; typical 0.25 μ A at $V_{DD} = 3.0$ V and $T_{amb} = 25$ °C
- 400 kHz two-wire I²C-bus interface (at $V_{DD} = 1.8$ to 5.5 V)
- Programmable clock output for peripheral devices: 32.768 kHz, 1024 Hz, 32 Hz and 1 Hz
- Alarm and timer functions
- Voltage-low detector
- Integrated oscillator capacitor
- Internal power-on reset
- I²C-bus slave address: read A3H; write A2H
- Open drain interrupt pin.

3. Applications

- Mobile telephones
- Portable instruments
- Fax machines
- Battery powered products.



PHILIPS

4. Quick reference data

Table 1: Quick reference data

Symbol	Parameter	Conditions	Min	Max	Unit
V _{DD}	supply voltage operating mode	I ² C-bus inactive; T _{amb} = 25 °C	1.0	5.5	V
		I ² C-bus active; f _{SCL} = 400 kHz; T _{amb} = -40 to +85 °C	1.8	5.5	V
I _{DD}	supply current; timer and CLKOUT disabled	f _{SCL} = 400 kHz	-	800	µA
		f _{SCL} = 100 kHz	-	200	µA
		f _{SCL} = 0 Hz; T _{amb} = 25 °C			
		V _{DD} = 5 V	-	550	nA
		V _{DD} = 2 V	-	450	nA
T _{amb}	operating ambient temperature		-40	+85	°C
T _{stg}	storage temperature		-65	+150	°C

5. Ordering information

Table 2: Ordering information

Type number	Package		Version
	Name	Description	
PCF8563P	DIP8	plastic dual in-line package; 8 leads (300 mil)	SOT97-1
PCF8563T	SO8	plastic small outline package; 8 leads; body width 3.9 mm	SOT96-1
PCF8563TS	TSSOP8	plastic thin shrink small outline package; 8 leads; body width 3.0 mm	SOT505-1

6. Block diagram

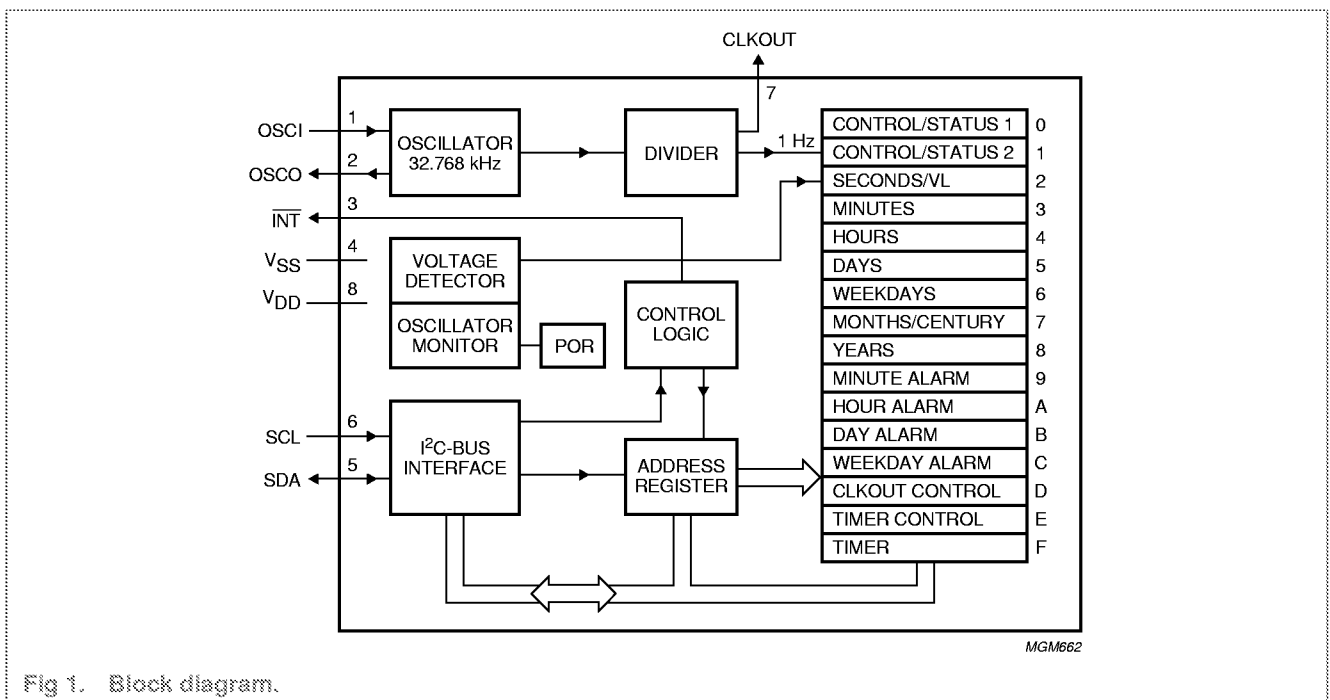
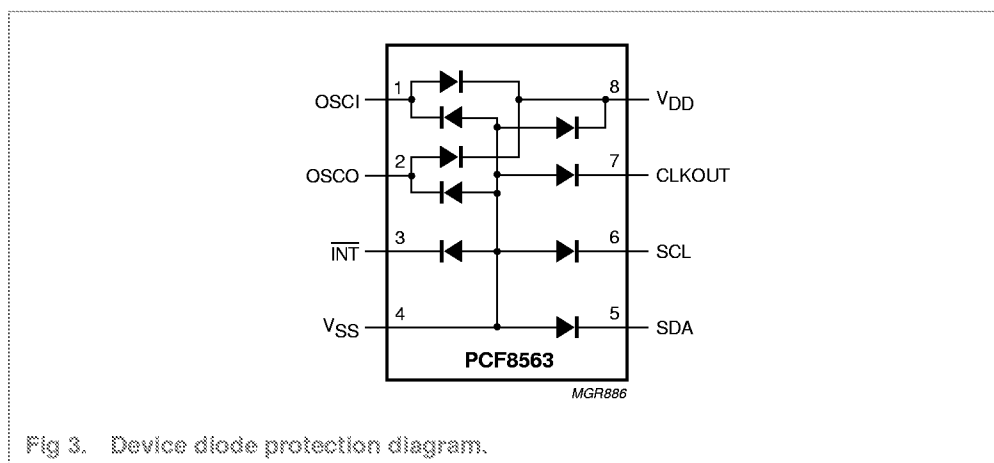
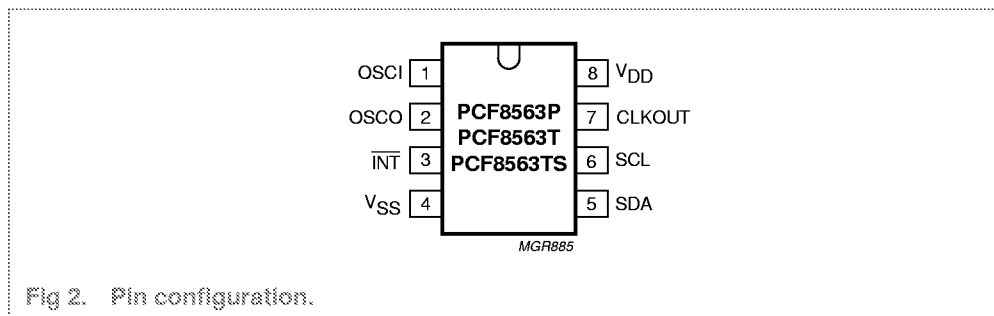

Fig 1. Block diagram.

7. Pinning information

7.1 Pinning



7.2 Pin description

Table 3: Pin description

Symbol	Pin	Description
OSCI	1	oscillator input
OSCO	2	oscillator output
$\overline{\text{INT}}$	3	interrupt output (open-drain; active LOW)
V _{SS}	4	ground
SDA	5	serial data I/O
SCL	6	serial clock input
CLKOUT	7	clock output (open-drain)
V _{DD}	8	positive supply

8. Functional description

The PCF8563 contains sixteen 8-bit registers with an auto-incrementing address register, an on-chip 32.768 kHz oscillator with an integrated capacitor, a frequency divider which provides the source clock for the Real-Time Clock (RTC), a programmable clock output, a timer, an alarm, a voltage-low detector and a 400 kHz I²C-bus interface.

All 16 registers are designed as addressable 8-bit parallel registers although not all bits are implemented. The first two registers (memory address 00H and 01H) are used as control and/or status registers. The memory addresses 02H through 08H are used as counters for the clock function (seconds up to year counters). Address locations 09H through 0CH contain alarm registers which define the conditions for an alarm. Address 0DH controls the CLKOUT output frequency. 0EH and 0FH are the timer control and timer registers, respectively.

The Seconds, Minutes, Hours, Days, Months, Years as well as the Minute alarm, Hour alarm and Day alarm registers are all coded in BCD format. The Weekdays and Weekday alarm register are not coded in BCD format.

When one of the RTC registers is read the contents of all counters are frozen. Therefore, faulty reading of the clock/calendar during a carry condition is prevented.

8.1 Alarm function modes

By clearing the MSB (bit AE = Alarm Enable) of one or more of the alarm registers, the corresponding alarm condition(s) will be active. In this way an alarm can be generated from once per minute up to once per week. The alarm condition sets the alarm flag, AF (bit 3 of Control/Status 2 register). The asserted AF can be used to generate an interrupt (\overline{INT}). Bit AF can only be cleared by software.

8.2 Timer

The 8-bit countdown timer (address 0FH) is controlled by the Timer Control register (address 0EH; see Table 25). The Timer Control register selects one of 4 source clock frequencies for the timer (4096, 64, 1, or $\frac{1}{60}$ Hz), and enables/disables the timer. The timer counts down from a software-loaded 8-bit binary value. At the end of every countdown, the timer sets the timer flag TF (see Table 7). The timer flag TF can only be cleared by software. The asserted timer flag TF can be used to generate an interrupt (\overline{INT}). The interrupt may be generated as a pulsed signal every countdown period or as a permanently active signal which follows the condition of TF. TI/TP (see Table 7) is used to control this mode selection. When reading the timer, the current countdown value is returned.

8.3 CLKOUT output

A programmable square wave is available at the CLKOUT pin. Operation is controlled by the CLKOUT frequency register (address 0DH; see Table 23). Frequencies of 32.768 kHz (default), 1024, 32 and 1 Hz can be generated for use as a system clock, microcontroller clock, input to a charge pump, or for calibration of the oscillator. CLKOUT is an open-drain output and enabled at power-on. If disabled it becomes high-impedance.

8.4 Reset

The PCF8563 includes an internal reset circuit which is active whenever the oscillator is stopped. In the reset state the I²C-bus logic is initialized and all registers, including the address pointer, are cleared with the exception of bits FE, VL, TD1, TD0, TESTC and AE which are set to logic 1.

8.5 Voltage-low detector and clock monitor

The PCF8563 has an on-chip voltage-low detector. When V_{DD} drops below V_{low} the VL bit (Voltage Low, bit 7 in the Seconds register) is set to indicate that reliable clock/calendar information is no longer guaranteed. The VL flag can only be cleared by software.

The VL bit is intended to detect the situation when V_{DD} is decreasing slowly for example under battery operation. Should V_{DD} reach V_{low} before power is re-asserted then the VL bit will be set. This will indicate that the time may be corrupted.

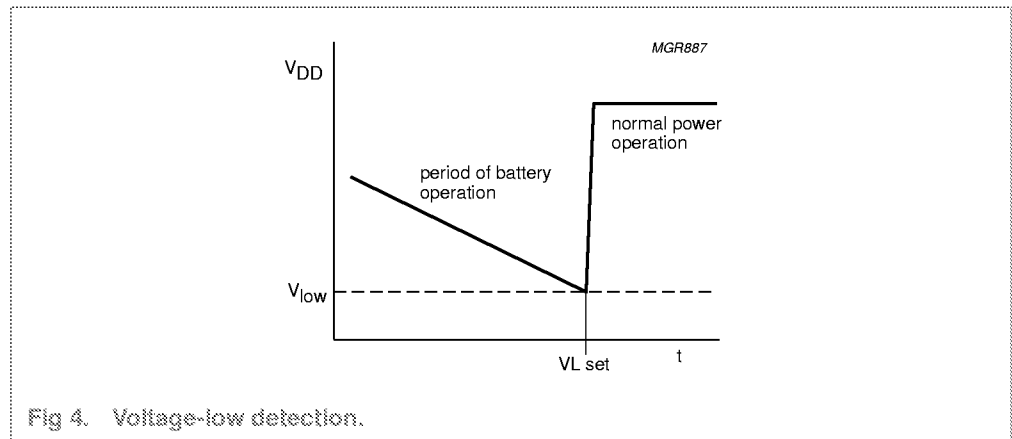

Fig 4. Voltage-low detection.

8.6 Register organization

Table 4: Registers overview

Bit positions labelled as '-' are not implemented; those labelled with '0' should always be written with logic 0.

Address	Register name	Bit 7	Bit 6	Bit 5	Bit 4	Bit 3	Bit 2	Bit 1	Bit 0
00H	Control/Status 1	TEST1	0	STOP	0	TESTC	0	0	0
01H	Control/Status 2	0	0	0	TI/TP	AF	TF	AIE	TIE
0DH	CLKOUT frequency	FE	-	-	-	-	-	FD1	FD0
0EH	Timer control	TE	-	-	-	-	-	TD1	TD0
0FH	Timer countdown value	<timer countdown value>							

Table 5: BCD formatted registers overview
 Bit positions labelled as '-' are not implemented.

Address	Register name	BCD format tens nibble				BCD format units nibble			
		Bit 7 2 ³	Bit 6 2 ²	Bit 5 2 ¹	Bit 4 2 ⁰	Bit 3 2 ³	Bit 2 2 ²	Bit 1 2 ¹	Bit 0 2 ⁰
02H	Seconds	VL				<seconds 00 to 59 coded in BCD>			
03H	Minutes	-				<minutes 00 to 59 coded in BCD>			
04H	Hours	-	-			<hours 00 to 23 coded in BCD>			
05H	Days	-	-			<days 01 to 31 coded in BCD>			
06H	Weekdays	-	-	-	-	-	<weekdays 0 to 6 > ^[1]		
07H	Months/Century	C	-	-		<months 01 to 12 coded in BCD>			
08H	Years					<years 00 to 99 coded in BCD>			
09H	Minute alarm	AE				<minute alarm 00 to 59 coded in BCD>			
0AH	Hour alarm	AE	-			<hour alarm 00 to 23 coded in BCD>			
0BH	Day alarm	AE	-			<day alarm 01 to 31 coded in BCD>			
0CH	Weekday alarm	AE	-	-	-	-	<weekday alarm 0 to 6 > ^[1]		

[1] Not coded in BCD.

8.6.1 Control/Status 1 register

Table 6: Control/Status 1 register bits description (address 00H)

Bit	Symbol	Description
7	TEST1	TEST1 = 0; normal mode. TEST1 = 1; EXT_CLK test mode; see Section 8.7.
5	STOP	STOP = 0; RTC source clock runs. STOP = 1; all RTC divider chain flip-flops are asynchronously set to logic 0; the RTC clock is stopped (CLKOUT at 32.768 kHz is still available).
3	TESTC	TESTC = 0; power-on reset override facility is disabled (set to logic 0 for normal operation). TESTC = 1; power-on reset override is enabled.
6, 4, 2 to 0	0	By default set to logic 0.

8.6.2 Control/Status 2 register

Table 7: Description of Control/Status 2 register bits description (address 01H)

Bit	Symbol	Description
7 to 5	0	By default set to logic 0.
4	TI/TP	TI/TP = 0: INT is active when TF is active (subject to the status of TIE). TI/TP = 1: INT pulses active according to Table 8 (subject to the status of TIE). Note that if AF and AIE are active then INT will be permanently active.
3	AF	When an alarm occurs, AF is set to logic 1. Similarly, at the end of a timer countdown, TF is set to logic 1. These bits maintain their value until overwritten by software. If both timer and alarm interrupts are required in the application, the source of the interrupt can be determined by reading these bits. To prevent one flag being overwritten while clearing another, a logic AND is performed during a write access. See Table 9 for the value descriptions of bits AF and TF.
2	TF	
1	AIE	Bits AIE and TIE activate or deactivate the generation of an interrupt when AF or TF is asserted, respectively. The interrupt is the logical OR of these two conditions when both AIE and TIE are set. AIE = 0: alarm interrupt disabled; AIE = 1: alarm interrupt enabled.
0	TIE	TIE = 0: timer interrupt disabled; TIE = 1: timer interrupt enabled.

Table 8: $\overline{\text{INT}}$ operation (bit TI/TP = 1)

Source clock (Hz)	$\overline{\text{INT}}$ [1] period (s)	
	n [2] = 1	n > 1
4 096	$\frac{1}{8192}$	$\frac{1}{4096}$
64	$\frac{1}{128}$	$\frac{1}{64}$
1	$\frac{1}{64}$	$\frac{1}{64}$
$\frac{1}{60}$	$\frac{1}{64}$	$\frac{1}{64}$

[1] TF and $\overline{\text{INT}}$ become active simultaneously.

[2] n = loaded countdown timer value. Timer stopped when n = 0.

Table 9: Value descriptions for bits AF and TF

R/W	Bit: AF		Bit: TF	
	Value	Description	Value	Description
Read	0	alarm flag inactive	0	timer flag inactive
	1	alarm flag active	1	timer flag active
Write	0	alarm flag is cleared	0	timer flag is cleared
	1	alarm flag remains unchanged	1	timer flag remains unchanged

8.6.3 Seconds, Minutes and Hours registers

Table 10: Seconds/VL register bits description (address 02H)

Bit	Symbol	Description
7	VL	VL = 0: reliable clock/calendar information is guaranteed; VL = 1: reliable clock/calendar information is no longer guaranteed.
6 to 0	<seconds>	These bits represent the current seconds value coded in BCD format; value = 00 to 59. Example: <seconds> = 101 1001, represents the value 59 s.

Table 11: Minutes register bits description (address 03H)

Bit	Symbol	Description
7	–	not implemented
6 to 0	<minutes>	These bits represent the current minutes value coded in BCD format; value = 00 to 59.

Table 12: Hours register bits description (address 04H)

Bit	Symbol	Description
7 to 6	–	not implemented
5 to 0	<hours>	These bits represent the current hours value coded in BCD format; value = 00 to 23.

8.6.4 Days, Weekdays, Months/Century and Years registers

Table 13: Days register bits description (address 05H)

Bit	Symbol	Description
7 to 6	–	not implemented
5 to 0	<days>	These bits represent the current day value coded in BCD format; value = 01 to 31. The PCF8563 compensates for leap years by adding a 29th day to February if the year counter contains a value which is exactly divisible by 4, including the year '00'.

Table 14: Weekdays register bits description (address 06H)

Bit	Symbol	Description
7 to 3	–	not implemented
2 to 0	<weekdays>	These bits represent the current weekday value 0 to 6; see Table 15. These bits may be re-assigned by the user.

Table 15: Weekday assignments

Day	Bit 2	Bit 1	Bit 0
Sunday	0	0	0
Monday	0	0	1
Tuesday	0	1	0
Wednesday	0	1	1
Thursday	1	0	0
Friday	1	0	1
Saturday	1	1	0

Table 16: Months/Century register bits description (address 07H)

Bit	Symbol	Description
7	C	Century bit. C = 0; indicates the century is 20xx. C = 1; indicates the century is 19xx. 'xx' indicates the value held in the Years register; see Table 13. This bit is toggled when the Years register overflows from 99 to 00. These bits may be re-assigned by the user.
6 to 5	–	not implemented
4 to 0	<months>	These bits represents the current month value coded in BCD format; value = 01 to 12; see Table 17.

Table 17: Month assignments

Month	Bit 4	Bit 3	Bit 2	Bit 1	Bit 0
January	0	0	0	0	1
February	0	0	0	1	0
March	0	0	0	1	1
April	0	0	1	0	0
May	0	0	1	0	1
June	0	0	1	1	0
July	0	0	1	1	1
August	0	1	0	0	0
September	0	1	0	0	1
October	1	0	0	0	0
November	1	0	0	0	1
December	1	0	0	1	0

Table 18: Years register bits description (address 08H)

Bit	Symbol	Description
7 to 0	<years>	This register represents the current year value coded in BCD format; value = 00 to 99.

8.6.5 Alarm registers

When one or more of the alarm registers are loaded with a valid minute, hour, day or weekday and its corresponding AE (Alarm Enable) bit is a logic 0, then that information will be compared with the current minute, hour, day and weekday. When all enabled comparisons first match, the bit AF (Alarm Flag) is set.

AF will remain set until cleared by software. Once AF has been cleared it will only be set again when the time increments to match the alarm condition once more. Alarm registers which have their AE bit set at logic 1 will be ignored.

Table 19: Minute alarm register bits description (address 09H)

Bit	Symbol	Description
7	AE	AE = 0; minute alarm is enabled. AE = 1; minute alarm is disabled.
6 to 0	<minute alarm>	These bits represents the minute alarm information coded in BCD format; value = 00 to 59.

Table 20: Hour alarm register bits description (address 0AH)

Bit	Symbol	Description
7	AE	AE = 0; hour alarm is enabled. AE = 1; hour alarm is disabled.
6 to 0	<hour alarm>	These bits represents the hour alarm information coded in BCD format; value = 00 to 23.

Table 21: Day alarm register bits description (address 0BH)

Bit	Symbol	Description
7	AE	AE = 0; day alarm is enabled. AE = 1; day alarm is disabled.
6 to 0	<day alarm>	These bits represents the day alarm information coded in BCD format; value = 01 to 31.

Table 22: Weekday alarm register bits description (address 0CH)

Bit	Symbol	Description
7	AE	AE = 0; weekday alarm is enabled. AE = 1; weekday alarm is disabled.
6 to 0	<weekday alarm>	These bits represents the weekday alarm information value 0 to 6.

8.6.6 CLKOUT frequency register

Table 23: CLKOUT frequency register bits description (address 0DH)

Bit	Symbol	Description
7	FE	FE = 0; the CLKOUT output is inhibited and the CLKOUT output is set to high-impedance. FE = 1; the CLKOUT output is activated.
6 to 2	–	not implemented
1	FD1	These bits control the frequency output (f_{CLKOUT}) on the CLKOUT pin; see Table 24.
0	FD0	

Table 24: CLKOUT frequency selection

FD1	FD0	f_{CLKOUT}
0	0	32.768 kHz
0	1	1 024 Hz
1	0	32 Hz
1	1	1 Hz

8.6.7 Countdown timer registers

The Timer register is an 8-bit binary countdown timer. It is enabled and disabled via the Timer control register bit TE. The source clock for the timer is also selected by the Timer control register. Other timer properties, e.g. interrupt generation, are controlled via the Control/status 2 register. For accurate read back of the countdown value, the I²C-bus clock SCL must be operating at a frequency of at least twice the selected timer clock.

Table 25: Timer control register bits description (address 0EH)

Bit	Symbol	Description
7	TE	TE = 0; timer is disabled. TE = 1; timer is enabled.
6 to 2	–	not implemented
1	TD1	Timer source clock frequency selection bits. These bits determine the source clock for the countdown timer, see Table 26. When not in use, TD1 and TD0 should be set to '11' ($\frac{1}{60}$ Hz) for power saving.
0	TD0	

Table 26: Timer source clock frequency selection

TD1	TD0	Timer source clock frequency (Hz)
0	0	4096
0	1	64
1	0	1
1	1	$\frac{1}{60}$

Table 27: Timer countdown value register bits description (address 0FH)

Bit	Symbol	Description
7 to 0	<timer countdown value>	This register holds the loaded countdown value 'n'.

$$\text{Countdown period} = \frac{n}{\text{Source clock frequency}}$$

8.7 EXT_CLK test mode

A test mode is available which allows for on-board testing. In this mode it is possible to set up test conditions and control the operation of the RTC.

The test mode is entered by setting bit TEST1 in the Control/Status1 register. The CLKOUT pin then becomes an input. The test mode replaces the internal 64 Hz signal with the signal that is applied to the CLKOUT pin. Every 64 positive edges applied to CLKOUT will then generate an increment of one second.

The signal applied to the CLKOUT pin should have a minimum pulse width of 300 ns and a minimum period of 1 000 ns. The internal 64 Hz clock, now sourced from CLKOUT, is divided down to 1 Hz by a 2⁶ divide chain called a pre-scaler. The pre-scaler can be set into a known state by using the STOP bit. When the STOP bit is set, the pre-scaler is reset to 0. STOP must be cleared before the pre-scaler can operate again. From a STOP condition, the first 1 s increment will take place after 32 positive edges on CLKOUT. Thereafter, every 64 positive edges will cause a 1 s increment.

Remark: Entry into EXT_CLK test mode is not synchronized to the internal 64 Hz clock. When entering the test mode, no assumption as to the state of the pre-scaler can be made.

8.7.1 Operation example

1. Enter the EXT_CLK test mode; set bit 7 of Control/Status 1 register (TEST = 1)
2. Set bit 5 of Control/Status 1 register (STOP = 1)
3. Clear bit 5 of Control/Status 1 register (STOP = 0)
4. Set time registers (Seconds, Minutes, Hours, Days, Weekdays, Months/Century and Years) to desired value
5. Apply 32 clock pulses to CLKOUT
6. Read time registers to see the first change
7. Apply 64 clock pulses to CLKOUT
8. Read time registers to see the second change.

Repeat steps 7 and 8 for additional increments.

8.8 Power-On Reset (POR) override mode

The POR duration is directly related to the crystal oscillator start-up time. Due to the long start-up times experienced by these types of circuits, a mechanism has been built in to disable the POR and hence speed up on-board test of the device. The setting of this mode requires that the I²C-bus pins, SDA and SCL, be toggled in a specific order as shown in Figure 5. All timing values are required minimum.

Once the override mode has been entered, the chip immediately stops being reset and normal operation starts i.e. entry into the EXT_CLK test mode via I²C-bus access. The override mode is cleared by writing a logic 0 to bit TESTC. Re-entry into the override mode is only possible after TESTC is set to logic 1. Setting TESTC to logic 0 during normal operation has no effect except to prevent entry into the POR override mode.

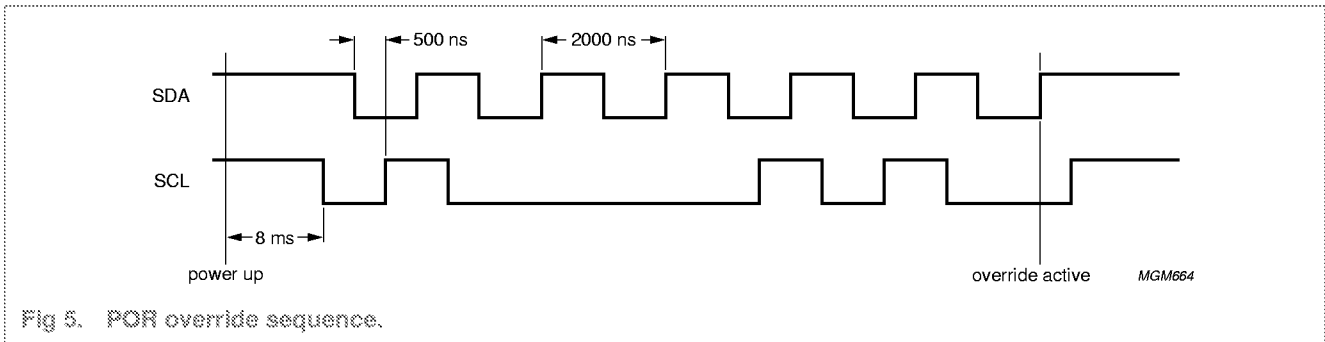

Fig 5. POR override sequence.

8.9 Serial interface

The serial interface of the PCF8563 is the I²C-bus. A detailed description of the I²C-bus specification, including applications, is given in the brochure: *The I²C-bus and how to use it*, order no. 9398 393 40011 or *I²C Peripherals Data Handbook IC12*.

8.9.1 Characteristics of the I²C-bus

The I²C-bus is for bidirectional, two-line communication between different ICs or modules. The two lines are a serial data line (SDA) and a serial clock line (SCL). Both lines must be connected to a positive supply via a pull-up resistor. Data transfer may be initiated only when the bus is not busy.

The I²C-bus system configuration is shown in Figure 6. A device generating a message is a 'transmitter', a device receiving a message is the 'receiver'. The device that controls the message is the 'master' and the devices which are controlled by the master are the 'slaves'.

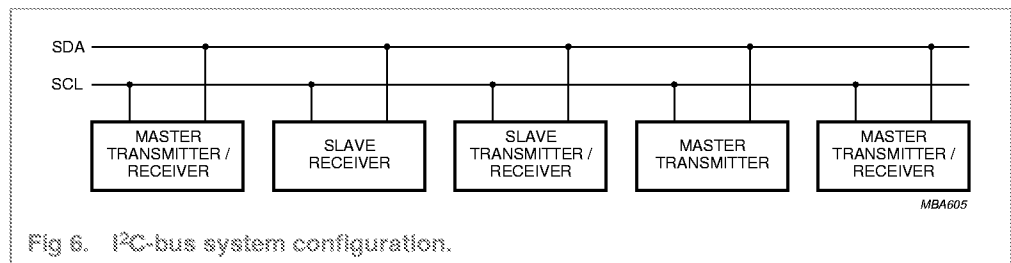

Fig 6. I²C-bus system configuration.

8.9.2 START and STOP conditions

Both data and clock lines remain HIGH when the bus is not busy. A HIGH-to-LOW transition of the data line, while the clock is HIGH is defined as the start condition (S). A LOW-to-HIGH transition of the data line while the clock is HIGH is defined as the stop condition (P); see Figure 7.

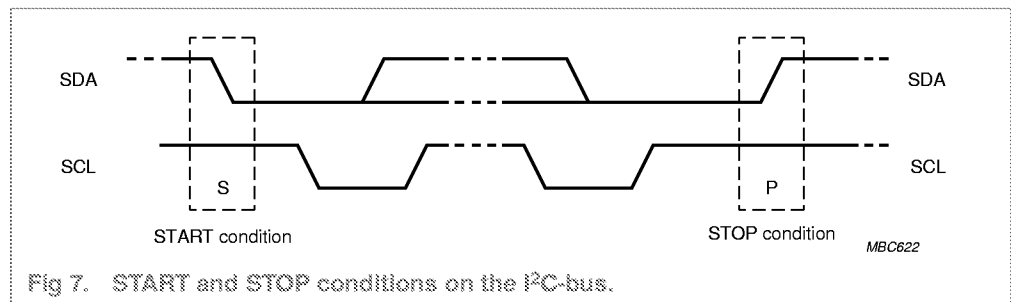

Fig 7. START and STOP conditions on the I²C-bus.

8.9.3 Bit transfer

One data bit is transferred during each clock pulse. The data on the SDA line must remain stable during the HIGH period of the clock pulse as changes in the data line at this time will be interpreted as a control signal; see Figure 8.

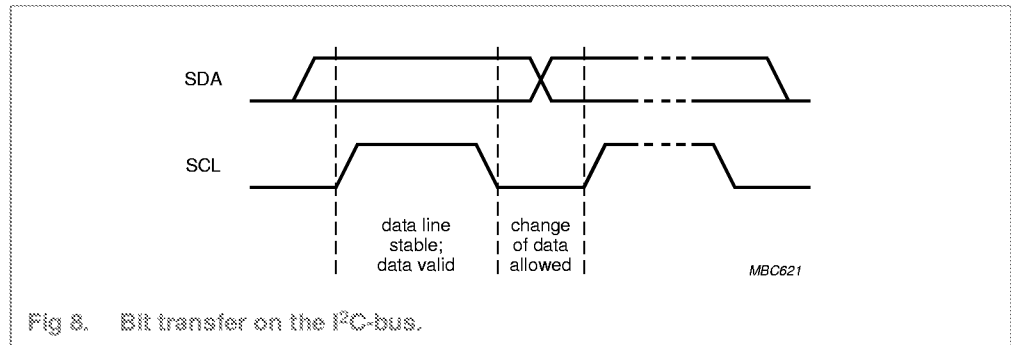

Fig 8. Bit transfer on the I²C-bus.

8.9.4 Acknowledge

The number of data bytes transferred between the START and STOP conditions from transmitter to receiver is unlimited. Each byte of eight bits is followed by an acknowledge bit. The acknowledge bit is a HIGH level signal put on the bus by the transmitter during which time the master generates an extra acknowledge related clock pulse.

A slave receiver which is addressed must generate an acknowledge after the reception of each byte. Also a master receiver must generate an acknowledge after the reception of each byte that has been clocked out of the slave transmitter.

The device that acknowledges must pull down the SDA line during the acknowledge clock pulse, so that the SDA line is stable LOW during the HIGH period of the acknowledge related clock pulse (set-up and hold times must be taken into consideration).

A master receiver must signal an end of data to the transmitter by not generating an acknowledge on the last byte that has been clocked out of the slave. In this event the transmitter must leave the data line HIGH to enable the master to generate a STOP condition.

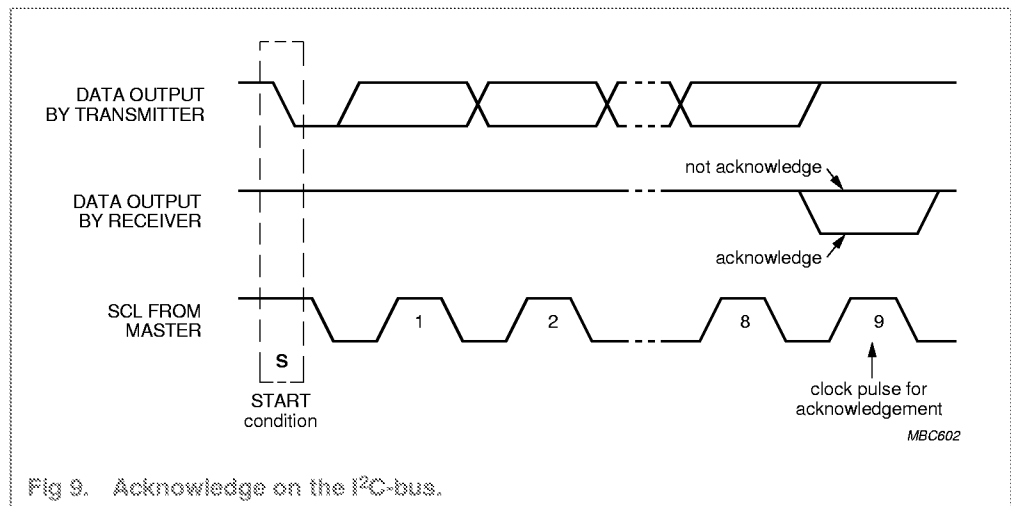

Fig 9. Acknowledge on the I²C-bus.

8.9.5 I²C-bus protocol

Addressing: Before any data is transmitted on the I²C-bus, the device which should respond is addressed first. The addressing is always carried out with the first byte transmitted after the start procedure.

The PCF8563 acts as a slave receiver or slave transmitter. Therefore the clock signal SCL is only an input signal, but the data signal SDA is a bidirectional line.

The PCF8563 slave address is shown in Figure 10.

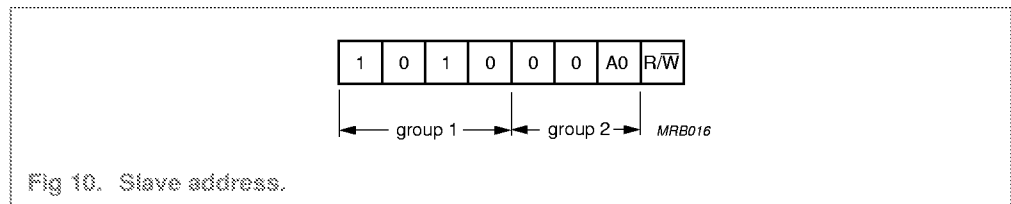

Fig 10. Slave address.

Clock/calendar read/write cycles: The I²C-bus configuration for the different PCF8563 read and write cycles are shown in Figure 11, 12 and 13. The word address is a four bit value that defines which register is to be accessed next. The upper four bits of the word address are not used.

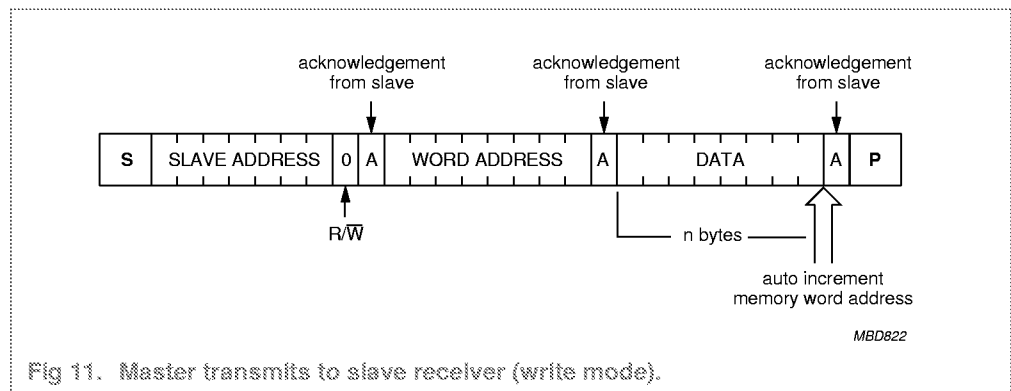

Fig 11. Master transmits to slave receiver (write mode).

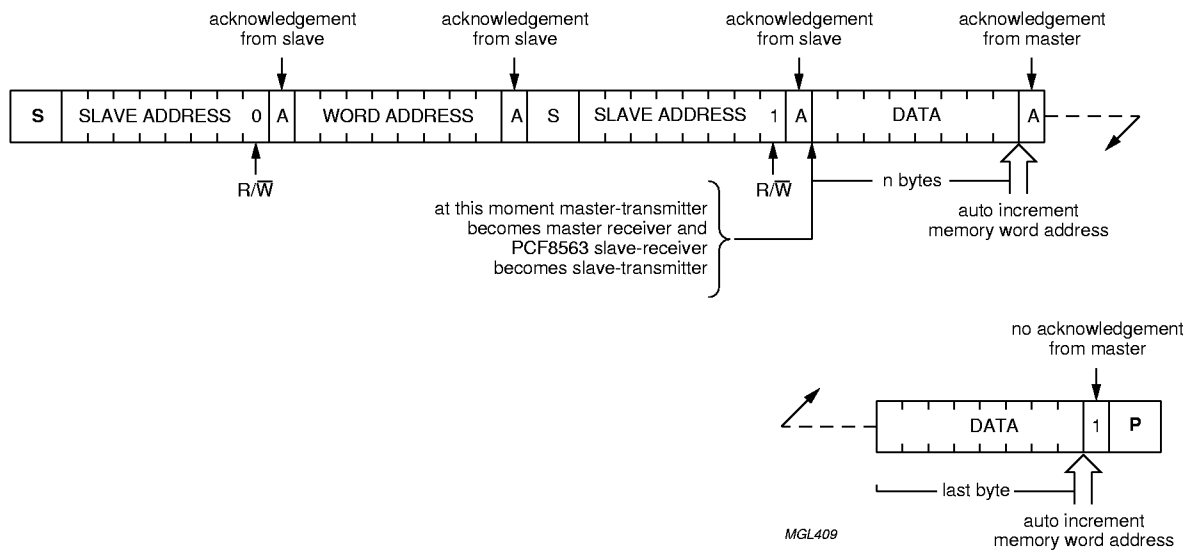

Fig 12. Master reads after setting word address (write word address; read data).

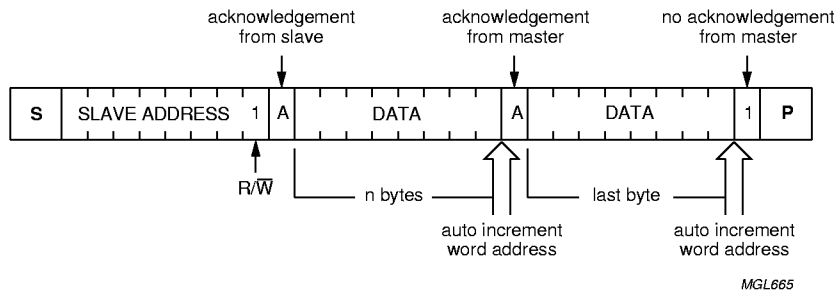

Fig 13. Master reads slave immediately after first byte (read mode).

9. Limiting values

Table 28: Limiting values

In accordance with the Absolute Maximum Rating System (IEC 60134).

Symbol	Parameter	Conditions	Min	Max	Unit
V _{DD}	supply voltage		-0.5	+6.5	V
I _{DD}	supply current		-50	+50	mA
V _I	input voltage on inputs SCL and SDA		-0.5	6.5	V
	input voltage on input OSC1		-0.5	V _{DD} + 0.5	V
V _O	output voltage on outputs CLKOUT and $\overline{\text{INT}}$		-0.5	6.5	V
I _I	DC input current at any input		-10	+10	mA
I _O	DC output current at any output		-10	+10	mA
P _{tot}	total power dissipation		-	300	mW
T _{amb}	operating ambient temperature		-40	+85	°C
T _{stg}	storage temperature		-65	+150	°C

10. Static characteristics

Table 29: Static characteristics

$V_{DD} = 1.8$ to 5.5 V; $V_{SS} = 0$ V; $T_{amb} = -40$ to 85 °C; $f_{OSC} = 32.768$ kHz; quartz $R_s = 40$ k Ω ; $C_L = 8$ pF; unless otherwise specified.

Symbol	Parameter	Conditions	Min	Typ	Max	Unit	
Supplies							
V_{DD}	supply voltage	I ² C-bus inactive; $T_{amb} = 25$ °C	1.0 ^[1]	–	5.5	V	
		I ² C-bus active; $f_{SCL} = 400$ kHz	1.8 ^[1]	–	5.5	V	
	supply voltage for reliable clock/calendar information	$T_{amb} = 25$ °C	V_{low}	–	5.5	V	
I_{DD1}	supply current; CLKOUT disabled (FE = 0)	$f_{SCL} = 400$ kHz	^[2] –	–	800	μ A	
		$f_{SCL} = 100$ kHz	–	–	200	μ A	
		$f_{SCL} = 0$ Hz; $T_{amb} = 25$ °C	^[2] –	–	–	–	–
		$V_{DD} = 5$ V	–	275	550	nA	
		$V_{DD} = 3$ V	–	250	500	nA	
		$V_{DD} = 2$ V	–	225	450	nA	
		$f_{SCL} = 0$ Hz	^[2] –	–	–	–	–
		$V_{DD} = 5$ V	–	500	750	nA	
		$V_{DD} = 3$ V	–	400	650	nA	
I_{DD2}	supply current; CLKOUT enabled ($f_{CLKOUT} = 32$ kHz; FE = 1)	$f_{SCL} = 0$ Hz; $T_{amb} = 25$ °C	^[2] –	–	–	–	
		$V_{DD} = 5$ V	–	825	1600	nA	
		$V_{DD} = 3$ V	–	550	1000	nA	
		$V_{DD} = 2$ V	–	425	800	nA	
		$f_{SCL} = 0$ Hz	^[2] –	–	–	–	–
		$V_{DD} = 5$ V	–	950	1700	nA	
		$V_{DD} = 3$ V	–	650	1100	nA	
		$V_{DD} = 2$ V	–	500	900	nA	
		–	–	–	–	–	–
Inputs							
V_{IL}	LOW-level input voltage		V_{SS}	–	$0.3V_{DD}$	V	
V_{IH}	HIGH-level input voltage		$0.7V_{DD}$	–	V_{DD}	V	
I_{LI}	input leakage current	$V_I = V_{DD}$ or V_{SS}	–1	–	+1	μ A	
C_i	input capacitance		^[3] –	–	7	pF	
Outputs							
$I_{OL(SDA)}$	LOW-level output current; pin SDA	$V_{OL} = 0.4$ V; $V_{DD} = 5$ V	–3	–	–	mA	
$I_{OL(INT)}$	LOW-level output current; pin \overline{INT}		–1	–	–	mA	
$I_{OL(CLKOUT)}$	LOW-level output current; pin CLKOUT		–1	–	–	mA	

Table 29: Static characteristics...continued

$V_{DD} = 1.8$ to 5.5 V; $V_{SS} = 0$ V; $T_{amb} = -40$ to 85 °C; $f_{OSC} = 32.768$ kHz; quartz $R_s = 40$ k Ω ; $C_L = 8$ pF; unless otherwise specified.

Symbol	Parameter	Conditions	Min	Typ	Max	Unit
$I_{OH(CLKOUT)}$	HIGH-level output current; pin CLKOUT	$V_{OH} = 4.6$ V; $V_{DD} = 5$ V	1	–	–	mA
I_{LO}	output leakage current	$V_O = V_{DD}$ or V_{SS}	–1	–	+1	μ A
Voltage detector						
V_{low}	voltage-low detection level	$T_{amb} = 25$ °C	–	0.9	1.0	V

- [1] For reliable oscillator start-up at power-up: $V_{DD(min)power-up} = V_{DD(min)} + 0.3$ V.
- [2] Timer source clock = $1/60$ Hz; SCL and SDA = V_{DD} .
- [3] Tested on sample basis.

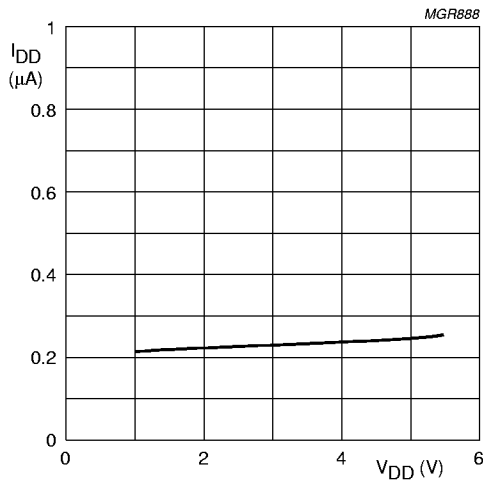

$T_{amb} = 25$ °C; Timer = 1 minute.

Fig 14. I_{DD} as a function of V_{DD} ; CLKOUT disabled.

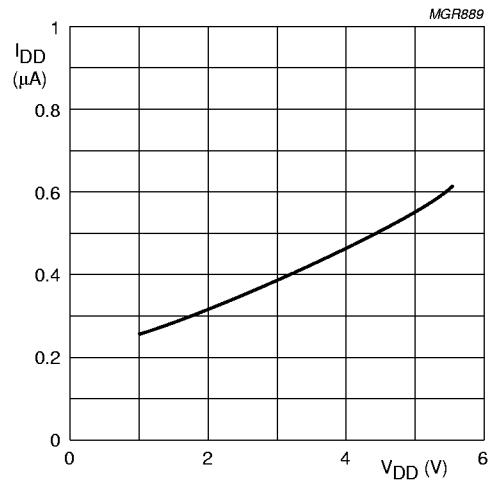

$T_{amb} = 25$ °C; Timer = 1 minute.

Fig 15. I_{DD} as a function of V_{DD} ; CLKOUT = 32 kHz.

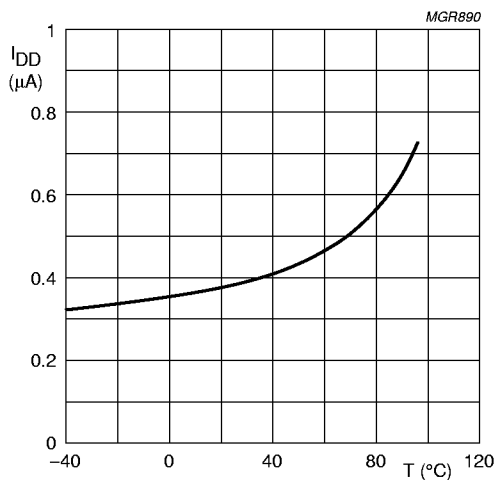

$V_{DD} = 3$ V; Timer = 1 minute.

Fig 16. I_{DD} as a function of T_{amb} ; CLKOUT = 32 kHz.

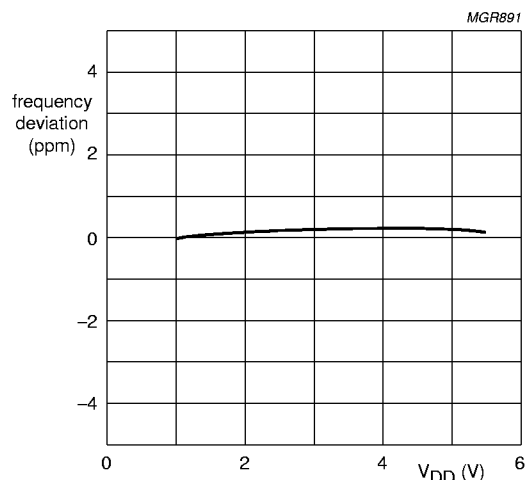

$T_{amb} = 25$ °C; normalized to $V_{DD} = 3$ V.

Fig 17. Frequency deviation as function of V_{DD} .

11. Dynamic characteristics

Table 30: Dynamic characteristics

$V_{DD} = 1.8$ to 5.5 V; $V_{SS} = 0$ V; $T_{amb} = -40$ to $+85$ °C; $f_{OSC} = 32.768$ kHz; quartz $R_s = 40$ k Ω ; $C_L = 8$ pF; unless otherwise specified.

Symbol	Parameter	Conditions	Min	Typ	Max	Unit
Oscillator						
$C_{L(integrated)}$	integrated load capacitance		15	25	35	pF
$\Delta f_{osc}/f_{osc}$	oscillator stability	$\Delta V_{DD} = 200$ mV; $T_{amb} = 25$ °C	–	2×10^{-7}	–	
Quartz crystal parameters ($f_{OSC} = 32.768$ kHz)						
R_s	series resistance		–	–	40	k Ω
C_L	parallel load capacitance		–	10	–	pF
C_T	trimmer capacitance		5	–	25	pF
CLKOUT output						
δ_{CLKOUT}	CLKOUT duty factor		[1] –	50	–	%
I²C-bus timing characteristics [2]						
f_{SCL}	SCL clock frequency		[3] –	–	400	kHz
$t_{HD;STA}$	START condition hold time		0.6	–	–	μ s
$t_{SU;STA}$	set-up time for a repeated START condition		0.6	–	–	μ s
t_{LOW}	SCL LOW time		1.3	–	–	μ s
t_{HIGH}	SCL HIGH time		0.6	–	–	μ s
t_r	SCL and SDA rise time		–	–	0.3	μ s
t_f	SCL and SDA fall time		–	–	0.3	μ s
C_b	capacitive bus line load		–	–	400	pF
$t_{SU;DAT}$	data set-up time		100	–	–	ns
$t_{HD;DAT}$	data hold time		0	–	–	ns
$t_{SU;STO}$	set-up time for STOP condition		4.0	–	–	μ s
t_{SW}	tolerable spike width on bus		–	–	50	ns

[1] Unspecified for $f_{CLKOUT} = 32.768$ kHz.

[2] All timing values are valid within the operating supply voltage range at T_{amb} and referenced to V_{IL} and V_{IH} with an input voltage swing of V_{SS} to V_{DD} .

[3] I²C-bus access time between two STARTs or between a START and a STOP condition to this device must be less than one second.

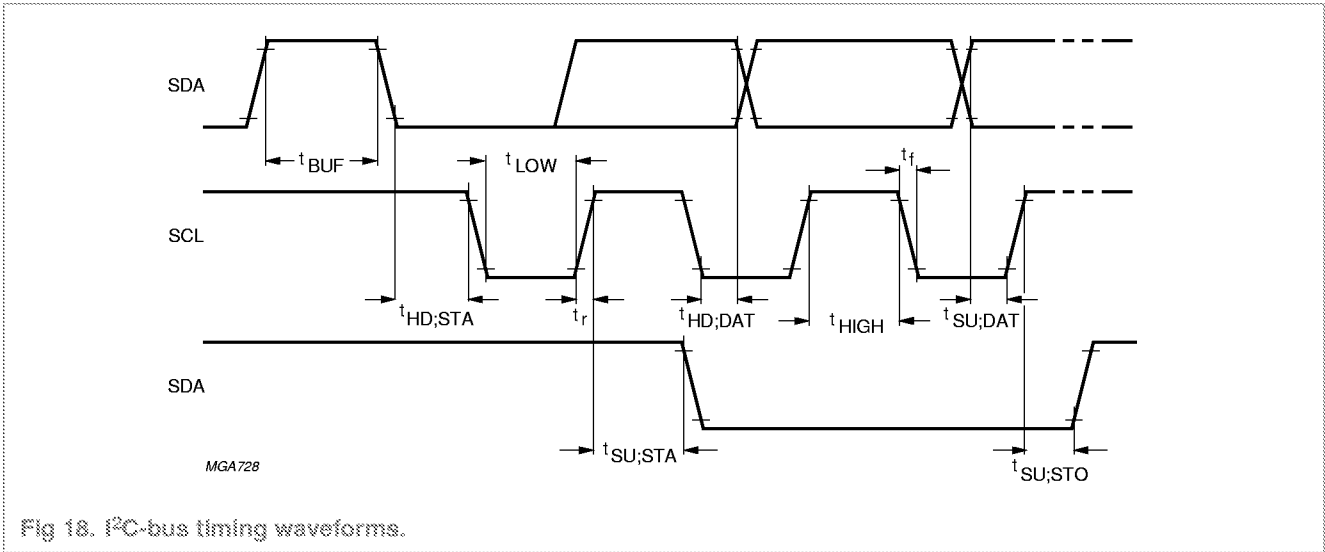

Fig 18. I2C-bus timing waveforms.

12. Application information

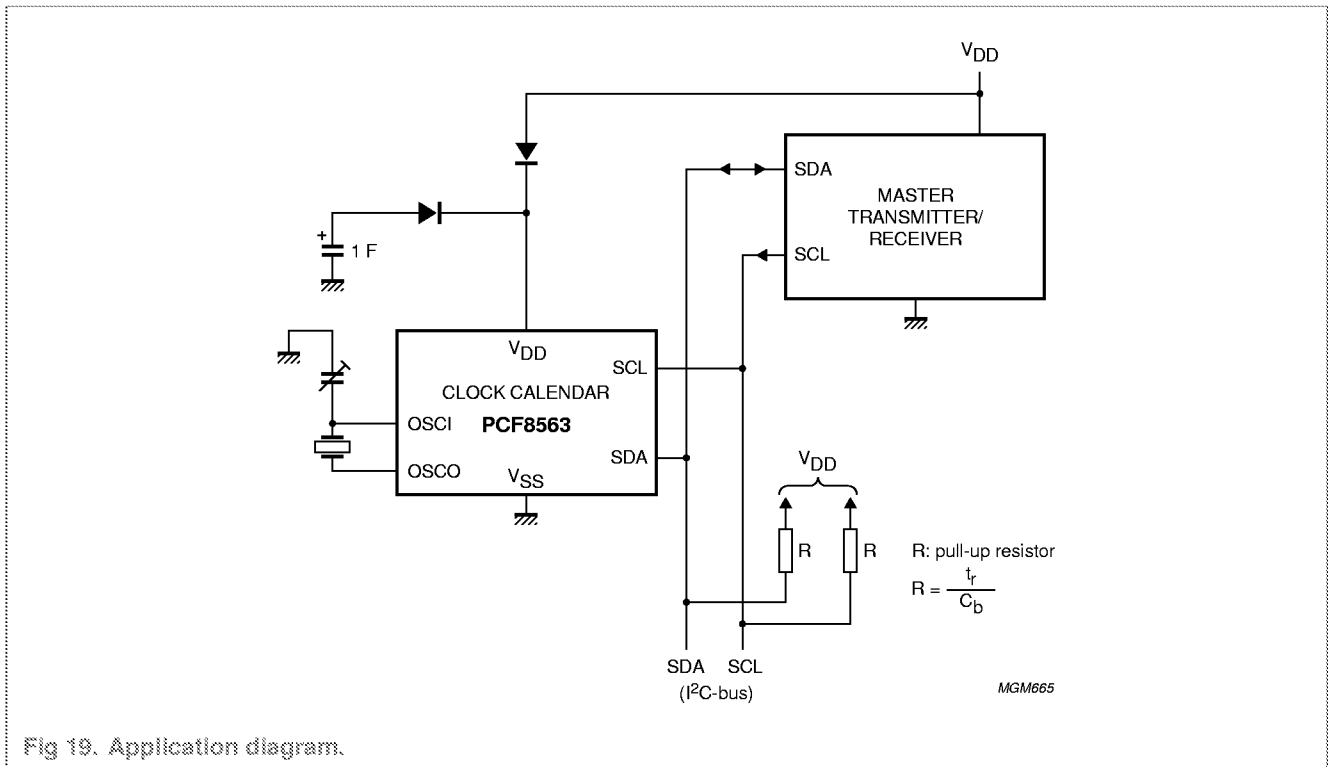

Fig 19. Application diagram.

12.1 Quartz crystal frequency adjustment

Method 1: Fixed OSCI capacitor — By evaluating the average capacitance necessary for the application layout a fixed capacitor can be used. The frequency is best measured via the 32.768 kHz signal available after power-on at the CLKOUT pin. The frequency tolerance depends on the quartz crystal tolerance, the capacitor tolerance and the device-to-device tolerance (on average $\pm 5 \times 10^{-6}$).

Average deviations of ± 5 minutes per year can be easily achieved.

Method 2: OSCI trimmer — The oscillator is tuned to the required accuracy by adjusting a trimmer capacitor on pin OSCI and measuring the 32.768 kHz signal available after power-on at the CLKOUT pin.

Method 3: OSCO output — Direct output measurement on pin OSCO (accounting for test probe capacitance).

13. Package outline

S08: plastic small outline package; 8 leads; body width 3.9 mm

SOT96-1

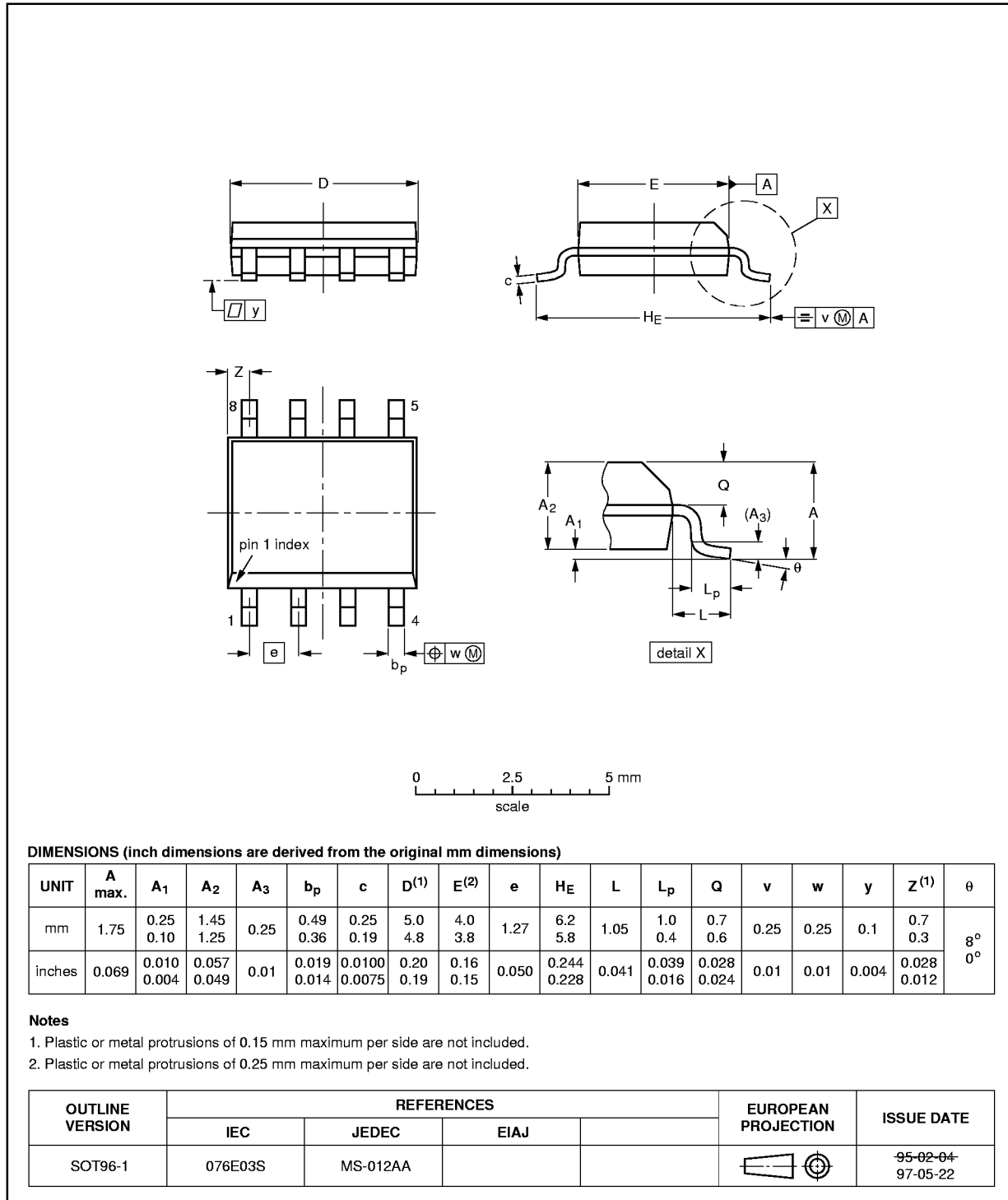

Fig 20. SOT96-1.

DIP8: plastic dual in-line package; 8 leads (300 mil)

SOT97-1

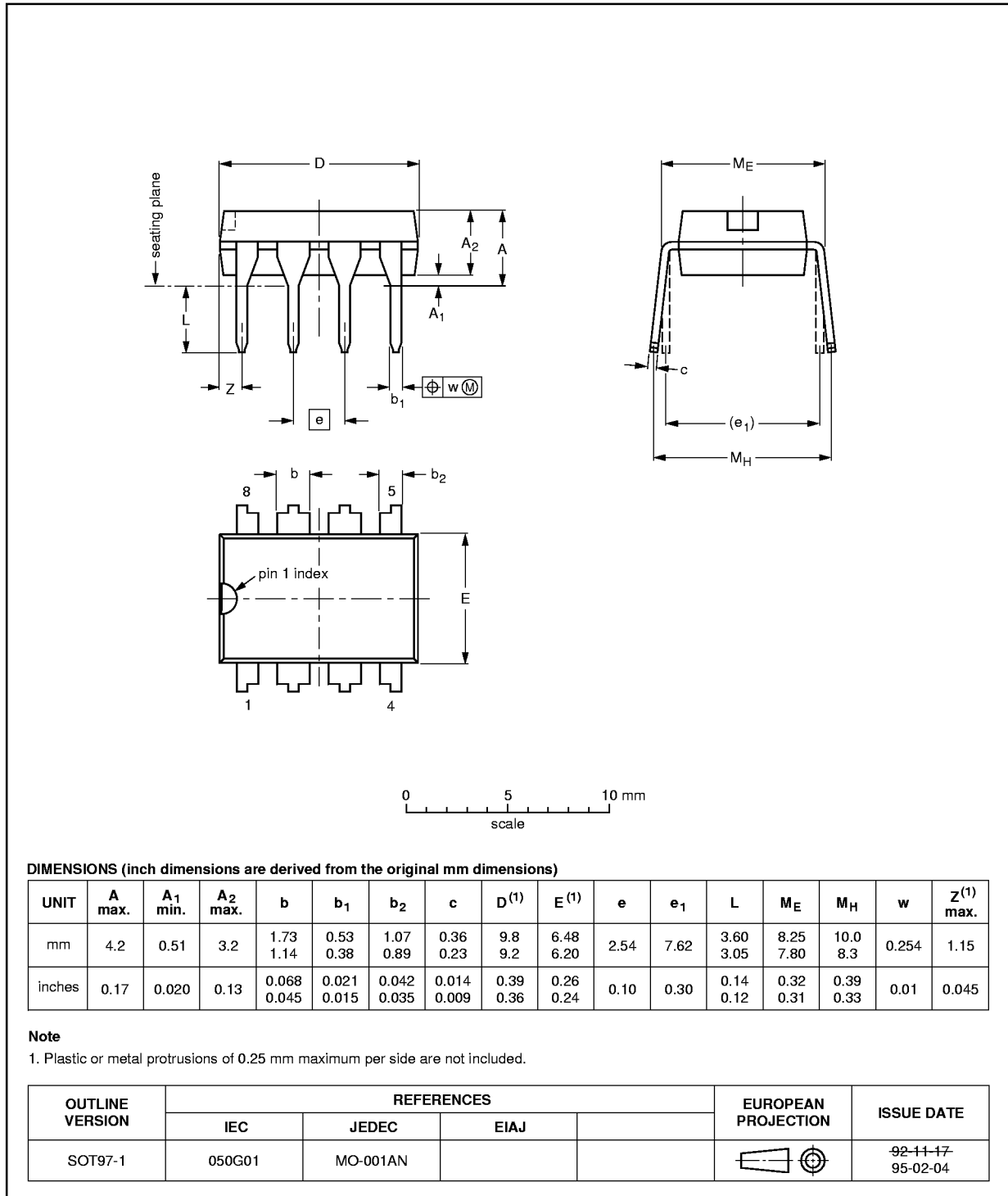

Fig 21. SOT97-1.

TSSOP8: plastic thin shrink small outline package; 8 leads; body width 3 mm

SOT505-1

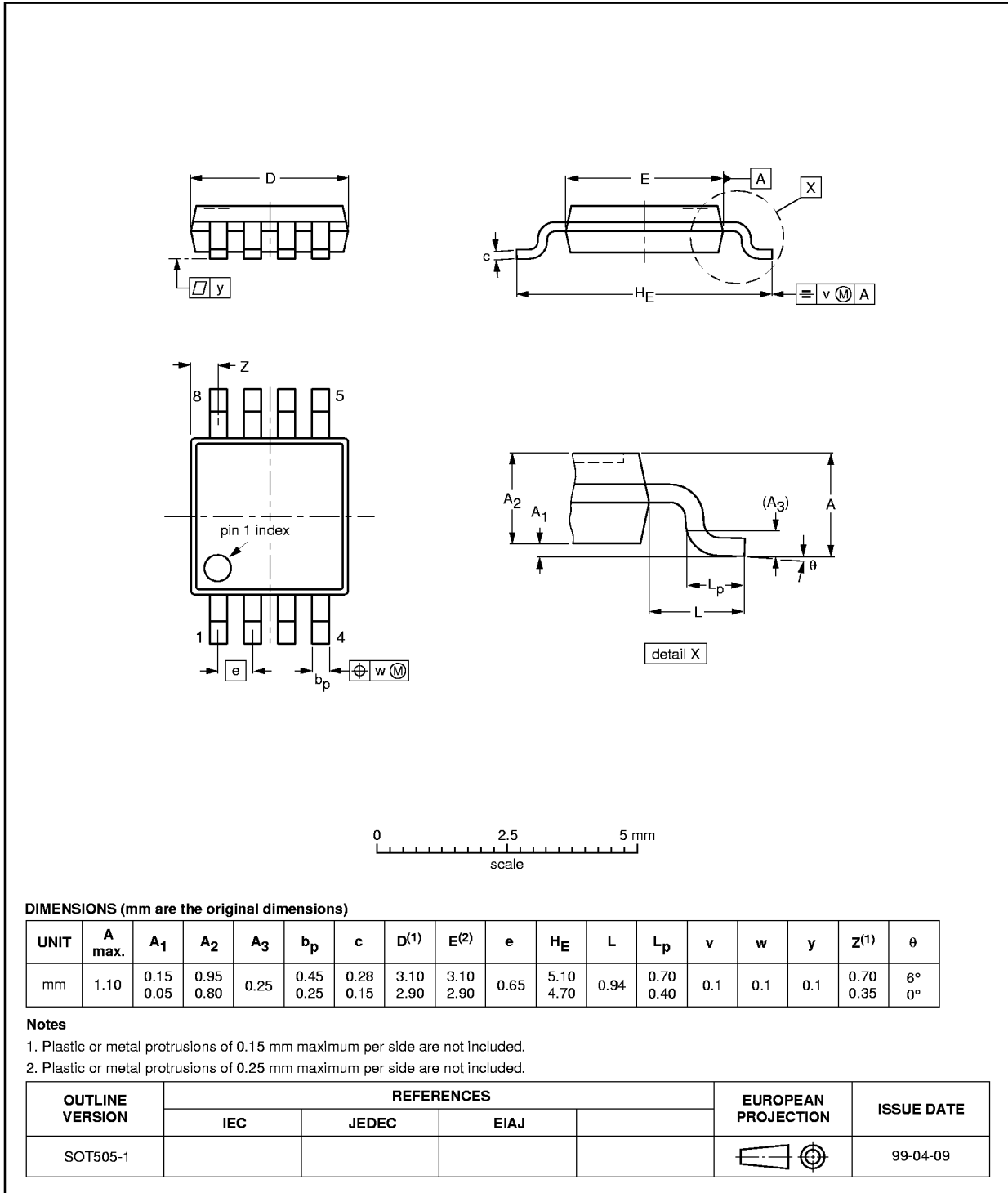

Fig 22. SOT505-1.

14. Soldering

14.1 Introduction

This text gives a very brief insight to a complex technology. A more in-depth account of soldering ICs can be found in our *Data Handbook IC26; Integrated Circuit Packages* (document order number 9398 652 90011).

There is no soldering method that is ideal for all IC packages. Wave soldering is often preferred when through-hole and surface mount components are mixed on one printed-circuit board. However, wave soldering is not always suitable for surface mount ICs, or for printed-circuit boards with high population densities. In these situations reflow soldering is often used.

14.2 Surface mount packages

14.2.1 Reflow soldering

Reflow soldering requires solder paste (a suspension of fine solder particles, flux and binding agent) to be applied to the printed-circuit board by screen printing, stencilling or pressure-syringe dispensing before package placement.

Several methods exist for reflowing; for example, infrared/convection heating in a conveyor type oven. Throughput times (preheating, soldering and cooling) vary between 100 and 200 seconds depending on heating method.

Typical reflow peak temperatures range from 215 to 250 °C. The top-surface temperature of the packages should preferably be kept below 230 °C.

14.2.2 Wave soldering

Conventional single wave soldering is not recommended for surface mount devices (SMDs) or printed-circuit boards with a high component density, as solder bridging and non-wetting can present major problems.

To overcome these problems the double-wave soldering method was specifically developed.

If wave soldering is used the following conditions must be observed for optimal results:

- Use a double-wave soldering method comprising a turbulent wave with high upward pressure followed by a smooth laminar wave.
- For packages with leads on two sides and a pitch (e):
 - larger than or equal to 1.27 mm, the footprint longitudinal axis is **preferred** to be parallel to the transport direction of the printed-circuit board;
 - smaller than 1.27 mm, the footprint longitudinal axis **must** be parallel to the transport direction of the printed-circuit board.

The footprint must incorporate solder thieves at the downstream end.

- For packages with leads on four sides, the footprint must be placed at a 45° angle to the transport direction of the printed-circuit board. The footprint must incorporate solder thieves downstream and at the side corners.

During placement and before soldering, the package must be fixed with a droplet of adhesive. The adhesive can be applied by screen printing, pin transfer or syringe dispensing. The package can be soldered after the adhesive is cured.

Typical dwell time is 4 seconds at 250 °C. A mildly-activated flux will eliminate the need for removal of corrosive residues in most applications.

14.2.3 Manual soldering

Fix the component by first soldering two diagonally-opposite end leads. Use a low voltage (24 V or less) soldering iron applied to the flat part of the lead. Contact time must be limited to 10 seconds at up to 300 °C.

When using a dedicated tool, all other leads can be soldered in one operation within 2 to 5 seconds between 270 and 320 °C.

14.3 Through-hole mount packages

14.3.1 Soldering by dipping or by solder wave

The maximum permissible temperature of the solder is 260 °C; solder at this temperature must not be in contact with the joints for more than 5 seconds. The total contact time of successive solder waves must not exceed 5 seconds.

The device may be mounted up to the seating plane, but the temperature of the plastic body must not exceed the specified maximum storage temperature ($T_{stg(max)}$). If the printed-circuit board has been pre-heated, forced cooling may be necessary immediately after soldering to keep the temperature within the permissible limit.

14.3.2 Manual soldering

Apply the soldering iron (24 V or less) to the lead(s) of the package, either below the seating plane or not more than 2 mm above it. If the temperature of the soldering iron bit is less than 300 °C it may remain in contact for up to 10 seconds. If the bit temperature is between 300 and 400 °C, contact may be up to 5 seconds.

14.4 Package related soldering information

Table 31: Suitability of IC packages for wave, reflow and dipping soldering methods

Mounting	Package	Soldering method		
		Wave	Reflow ^[1]	Dipping
Through-hole mount	DBS, DIP, HDIP, SDIP, SIL	suitable ^[2]	–	suitable
Surface mount	BGA, SQFP	not suitable	suitable	–
	HLQFP, HSQFP, HSOP, HTSSOP, SMS	not suitable ^[3]	suitable	–
	PLCC ^[4] , SO, SOJ	suitable	suitable	–
	LQFP, QFP, TQFP	not recommended ^[4] ^[5]	suitable	–
	SSOP, TSSOP, VSO	not recommended ^[6]	suitable	–

- [1] All surface mount (SMD) packages are moisture sensitive. Depending upon the moisture content, the maximum temperature (with respect to time) and body size of the package, there is a risk that internal or external package cracks may occur due to vaporization of the moisture in them (the so called popcorn effect). For details, refer to the Drypack information in the *Data Handbook IC26; Integrated Circuit Packages; Section: Packing Methods*.
- [2] For SDIP packages, the longitudinal axis must be parallel to the transport direction of the printed-circuit board.
- [3] These packages are not suitable for wave soldering as a solder joint between the printed-circuit board and heatsink (at bottom version) can not be achieved, and as solder may stick to the heatsink (on top version).
- [4] If wave soldering is considered, then the package must be placed at a 45° angle to the solder wave direction. The package footprint must incorporate solder thieves downstream and at the side corners.
- [5] Wave soldering is only suitable for LQFP, QFP and TQFP packages with a pitch (e) equal to or larger than 0.8 mm; it is definitely not suitable for packages with a pitch (e) equal to or smaller than 0.65 mm.
- [6] Wave soldering is only suitable for SSOP and TSSOP packages with a pitch (e) equal to or larger than 0.65 mm; it is definitely not suitable for packages with a pitch (e) equal to or smaller than 0.5 mm.

15. Revision history

Rev	Date	CPCN	Description
01	990416	-	<p>This data sheet supersedes the version of 1998 Mar 25 (9397 750 03282):</p> <ul style="list-style-type: none"> • The format of this specification has been redesigned to comply with Philips Semiconductors' new presentation and information standard • Added Figure 3 "Device diode protection diagram." on page 3 • Added Figure 4 "Voltage-low detection." on page 5 • Added paragraph in Section 8.5 "Voltage-low detector and clock monitor" on page 5 • Added Figure 14 to 17 on page 18 in Section 10.

16. Data sheet status

Datasheet status	Product status	Definition ^[1]
Objective specification	Development	This data sheet contains the design target or goal specifications for product development. Specification may change in any manner without notice.
Preliminary specification	Qualification	This data sheet contains preliminary data, and supplementary data will be published at a later date. Philips Semiconductors reserves the right to make changes at any time without notice in order to improve design and supply the best possible product.
Product specification	Production	This data sheet contains final specifications. Philips Semiconductors reserves the right to make changes at any time without notice in order to improve design and supply the best possible product.

[1] Please consult the most recently issued data sheet before initiating or completing a design.

17. Definitions

Short-form specification — The data in a short-form specification is extracted from a full data sheet with the same type number and title. For detailed information see the relevant data sheet or data handbook.

Limiting values definition — Limiting values given are in accordance with the Absolute Maximum Rating System (IEC 60134). Stress above one or more of the limiting values may cause permanent damage to the device. These are stress ratings only and operation of the device at these or at any other conditions above those given in the Characteristics sections of the specification is not implied. Exposure to limiting values for extended periods may affect device reliability.

Application information — Applications that are described herein for any of these products are for illustrative purposes only. Philips Semiconductors make no representation or warranty that such applications will be suitable for the specified use without further testing or modification.

18. Disclaimers

Life support — These products are not designed for use in life support appliances, devices, or systems where malfunction of these products can reasonably be expected to result in personal injury. Philips Semiconductors

customers using or selling these products for use in such applications do so at their own risk and agree to fully indemnify Philips Semiconductors for any damages resulting from such application.

Right to make changes — Philips Semiconductors reserves the right to make changes, without notice, in the products, including circuits, standard cells, and/or software, described or contained herein in order to improve design and/or performance. Philips Semiconductors assumes no responsibility or liability for the use of any of these products, conveys no licence or title under any patent, copyright, or mask work right to these products, and makes no representations or warranties that these products are free from patent, copyright, or mask work right infringement, unless otherwise specified.

19. Licenses

Purchase of Philips I²C components



Purchase of Philips I²C components conveys a license under the Philips' I²C patent to use the components in the I²C system provided the system conforms to the I²C specification defined by Philips. This specification can be ordered using the code 9398 393 40011.

Philips Semiconductors - a worldwide company

Argentina: see South America

Australia: Tel. +61 29 805 4455, Fax. +61 29 805 4466

Austria: Tel. +43 160 101, Fax. +43 160 101 1210

Belarus: Tel. +375 17 220 0733, Fax. +375 17 220 0773

Belgium: see The Netherlands

Brazil: see South America

Bulgaria: Tel. +359 268 9211, Fax. +359 268 9102

Canada: Tel. +1 800 234 7381

China/Hong Kong: Tel. +852 2 319 7888, Fax. +852 2 319 7700

Colombia: see South America

Czech Republic: see Austria

Denmark: Tel. +45 3 288 2636, Fax. +45 3 157 0044

Finland: Tel. +358 961 5800, Fax. +358 96 158 0920

France: Tel. +33 14 099 6161, Fax. +33 14 099 6427

Germany: Tel. +49 40 23 5360, Fax. +49 402 353 6300

Hungary: see Austria

India: Tel. +91 22 493 8541, Fax. +91 22 493 8722

Indonesia: see Singapore

Ireland: Tel. +353 17 64 0000, Fax. +353 17 64 0200

Israel: Tel. +972 36 45 0444, Fax. +972 36 49 1007

Italy: Tel. +39 26 752 2531, Fax. +39 26 752 2557

Japan: Tel. +81 33 740 5130, Fax. +81 33 740 5077

Korea: Tel. +82 27 09 1412, Fax. +82 27 09 1415

Malaysia: Tel. +60 37 50 5214, Fax. +60 37 57 4880

Mexico: Tel. +9-5 800 234 7381

Middle East: see Italy

Netherlands: Tel. +31 40 278 2785, Fax. +31 40 278 8399

New Zealand: Tel. +64 98 49 4160, Fax. +64 98 49 7811

Norway: Tel. +47 22 74 8000, Fax. +47 22 74 8341

Philippines: Tel. +63 28 16 6380, Fax. +63 28 17 3474

Poland: Tel. +48 22 612 2831, Fax. +48 22 612 2327

Portugal: see Spain

Romania: see Italy

Russia: Tel. +7 095 755 6918, Fax. +7 095 755 6919

Singapore: Tel. +65 350 2538, Fax. +65 251 6500

Slovakia: see Austria

Slovenia: see Italy

South Africa: Tel. +27 11 470 5911, Fax. +27 11 470 5494

South America: Tel. +55 11 821 2333, Fax. +55 11 829 1849

Spain: Tel. +34 33 01 6312, Fax. +34 33 01 4107

Sweden: Tel. +46 86 32 2000, Fax. +46 86 32 2745

Switzerland: Tel. +41 14 88 2686, Fax. +41 14 81 7730

Taiwan: Tel. +886 22 134 2865, Fax. +886 22 134 2874

Thailand: Tel. +66 27 45 4090, Fax. +66 23 98 0793

Turkey: Tel. +90 212 279 2770, Fax. +90 212 282 6707

Ukraine: Tel. +380 44 264 2776, Fax. +380 44 268 0461

United Kingdom: Tel. +44 181 730 5000, Fax. +44 181 754 8421

United States: Tel. +1 800 234 7381

Uruguay: see South America

Vietnam: see Singapore

Yugoslavia: Tel. +381 11 62 5344, Fax. +381 11 63 5777

For all other countries apply to: Philips Semiconductors,
Marketing & Sales Communications,
Building BE, P.O. Box 218, 5600 MD EINDHOVEN,
The Netherlands, Fax. +31 40 272 4825

Internet: <http://www.semiconductors.philips.com>

Contents

1	General description	1	16	Data sheet status	28
2	Features	1	17	Definitions	28
3	Applications	1	18	Disclaimers	28
4	Quick reference data	2	19	Licenses	28
5	Ordering information	2			
6	Block diagram	2			
7	Pinning information	3			
7.1	Pinning	3			
7.2	Pin description	3			
8	Functional description	4			
8.1	Alarm function modes	4			
8.2	Timer	4			
8.3	CLKOUT output	4			
8.4	Reset	5			
8.5	Voltage-low detector and clock monitor . .	5			
8.6	Register organization	5			
8.6.1	Control/Status 1 register	6			
8.6.2	Control/Status 2 register	7			
8.6.3	Seconds, Minutes and Hours registers	8			
8.6.4	Days, Weekdays, Months/Century and Years registers	8			
8.6.5	Alarm registers	10			
8.6.6	CLKOUT frequency register	11			
8.6.7	Countdown timer registers	11			
8.7	EXT_CLK test mode	12			
8.7.1	Operation example	12			
8.8	Power-On Reset (POR) override mode . .	12			
8.9	Serial interface	13			
8.9.1	Characteristics of the I ² C-bus	13			
8.9.2	START and STOP conditions	13			
8.9.3	Bit transfer	14			
8.9.4	Acknowledge	14			
8.9.5	I ² C-bus protocol	15			
9	Limiting values	16			
10	Static characteristics	17			
11	Dynamic characteristics	19			
12	Application information	21			
12.1	Quartz crystal frequency adjustment . . .	21			
13	Package outline	22			
14	Soldering	25			
14.1	Introduction	25			
14.2	Surface mount packages	25			
14.2.1	Reflow soldering	25			
14.2.2	Wave soldering	25			
14.2.3	Manual soldering	26			
14.3	Through-hole mount packages	26			
14.3.1	Soldering by dipping or by solder wave . .	26			
14.3.2	Manual soldering	26			
14.4	Package related soldering information . .	27			
15	Revision history	27			



PHILIPS

Let's make things better.