

- ◆ **CMOS Low Power Consumption**
- ◆ **Operating Voltage : 0.9V~10.0V**
- ◆ **Output Voltage Range: 2.0V~7.0V**
- ◆ **Output Voltage Accuracy: ±2.5%**
- ◆ **Oscillator Frequency: 30kHz**

■ Applications

- Cellular phones, pagers
- Palmtops
- Cameras, video recorders
- Portable equipment

■ General Description

The XC6373 is a group of PWM controlled step-up DC/DC converter ICs. The XC6373 series employs CMOS process and laser trimming technologies so as to attain low power and high accuracy. The implementation of a new phase compensation circuit and a slow start function ensure excellent transient response and improved performance. The series is particularly suited for use with pager applications because of their low power consumption and low noise characteristics. Output voltage can be selected from 2.0V to 7.0V in 0.1V increments (accuracy; ±2.5%). Oscillator frequency is set at 30kHz (±20%) so as to attain the lowest consumption current possible. A step-up converter circuit can be configured using the XC6373 IC with a coil, a diode, and a capacitor. 5-pin packages, which are provided with either a CE (Chip enable) function that reduces power consumption during shut-down mode, or a V_{DD} pin (separated power and voltage detect pins) are available. SOT-89 small package.

■ Features

- Operating (start-up) voltage range:** 0.9V~10V
- Output voltage range:** 2.0V~7.0V in 0.1V increments
- Highly accurate:** Set-up voltage ±2.5%
- Oscillator frequency:** 30kHz (±20%)
- Maximum output current (Tr. Built-In) :** 50mA (TYP.)
at V_{IN}=3.0V, V_{OUT}=5.0V Note (1)
- Highly efficient (Tr. Built-In):** 82% (TYP.)
at V_{IN}=3.0V, V_{OUT}=5.0V Note (1)
- Either chip enable or independent V_{OUT} pin option is selectable for 5-pin package units.**
- Phase compensation and slow start-up circuits included.**
- Small Package:** SOT-89 mini-power mold (3-pin, 5-pin)

Note (1): Performance depends on external components and PCB layout.

■ Selection Guide

PART TYPE	OPERATION MODE	PACKAGE	SWITCHING	ADDITIONAL FUNCTION	FEATURES
XC6373A	PWM	SOT-89-3	Built-in Transistor "Lx" lead		Switching transistor incorporated standard type. Low ripple and highly efficient from low current to high current.
XC6373C	PWM	SOT-89-5	Built-in Transistor "Lx" lead	Chip Enable(CE) Function	Stand-by (CE) capability added version to the XC6373A. Stand-by current; 0.50μA max.
XC6373E	PWM	SOT-89-5	Built-in Transistor "Lx" lead	Separatated "V _{DD} " and "V _{OUT} "	Individual power supply and set-up voltage sensing leads are available.

Pin Configuration

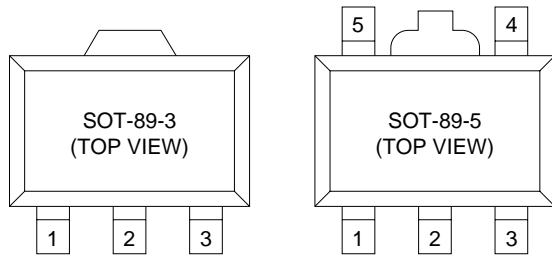

Pin Assignment

(XC6373A)

PIN NUMBER	PIN NAME	FUNCTION
1	V _{SS}	Ground
2	V _{OUT}	Output voltage monitor, IC internal power supply
3	L _x	Switch

(XC6373C)

PIN NUMBER	PIN NAME	FUNCTION
5	V _{SS}	Ground
2	V _{OUT}	Output voltage monitor, IC internal power supply
4	L _x	Switch
3	CE	Chip enable
1	NC	No connection

(XC6373E)

PIN NUMBER	PIN NAME	FUNCTION
5	V _{SS}	Ground
2	V _{DD}	IC internal power supply
4	L _x	Switch
3	V _{OUT}	Output voltage monitor
1	NC	No connection

Block Diagram

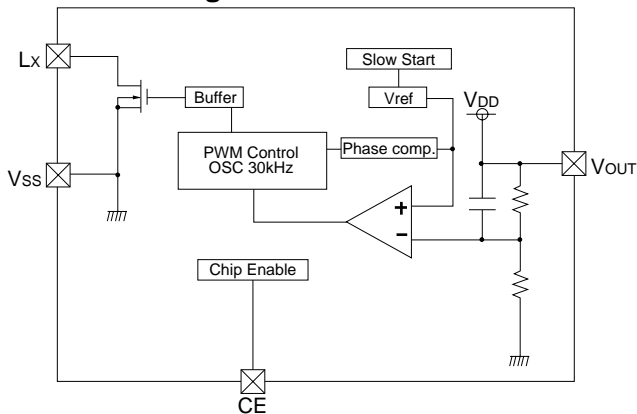

Note: The CE pin is only used with the XC6373C.

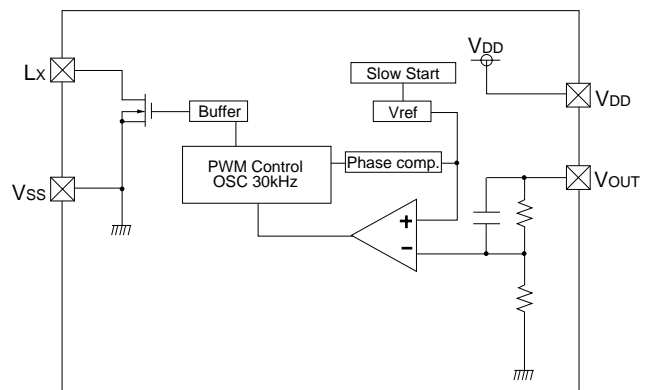

Note: The V_{DD} pin is only used with the XC6373E.

Absolute Maximum Ratings

Ta=25°C

PARAMETER	SYMBOL	CONDITIONS	UNIT
V _{OUT} Input Voltage	V _{OUT}	12	V
Lx Pin Voltage	V _{Lx}	12	V
Lx Pin Current	I _{Lx}	400	mA
Continuous Total Power Dissipation	P _d	500	mW
Operating Ambient temperature	T _{opr}	-30 ~ +80	°C
Storage Temperature	T _{stg}	-40 ~ +125	°C

Electrical Characteristics

XC6373A300PR V_{OUT}=3.0V, F_{OSC}=30kHz

Ta=25°C

PARAMETER	SYMBOL	CONDITIONS	MIN	TYP	MAX	UNIT
Output Voltage	V _{OUT}		2.925	3.000	3.075	V
Maximum Input Voltage	V _{IN}		10			V
Operation Start-up Voltage	V _{ST1}	External Components Connected. I _{OUT} =1mA.			0.90	V
Oscillation Start-up Voltage	V _{ST2}	No external components. Apply voltage to V _{OUT} . Lx :10kΩ pull-up to 5V.			0.80	V
Supply Current 1	I _{DD1}	Same as V _{ST2} . Apply output voltage X 0.95 to V _{OUT} .		13.1	21.9	μA
Supply Current 2	I _{DD2}	Same as V _{ST2} . Apply output voltage X 1.1 to V _{OUT} .		3.9	7.9	μA
Lx Switch-On Resistance	R _{SWON}	Same as I _{DD1} . V _{Lx} =0.4V.		3.4	5.7	Ω
Lx Leak Current	I _{LXL}	No external components. V _{OUT} =V _{Lx} =10V.			1.0	μA
Oscillator Frequency	F _{OSC}	Same as I _{DD1} . Measuring of Lx waveform.	24	30	36	kHz
Maximum Duty Ratio	MAXDTY	Same as I _{DD1} . Measuring of Lx waveform.	80	87	92	%
Efficiency	EFFI			77		%
Slow-Start Time	T _{SS}		4.0	10.0	20.0	mS

Measuring conditions: Unless otherwise specified, V_{IN}=V_{OUT} X 0.6, I_{OUT}=15mA. See Typical Application Circuits, Fig.1.

XC6373A330PR V_{OUT}=3.3V, F_{OSC}=30kHz

Ta=25°C

PARAMETER	SYMBOL	CONDITIONS	MIN	TYP	MAX	UNIT
Output Voltage	V _{OUT}		3.128	3.300	3.383	V
Maximum Input Voltage	V _{IN}		10			V
Operation Start-up Voltage	V _{ST1}	External Components Connected. I _{OUT} =1mA.			0.90	V
Oscillation Start-up Voltage	V _{ST2}	No external components. Apply voltage to V _{OUT} . Lx 10kΩ pull-up to 5V.			0.80	V
Supply Current 1	I _{DD1}	Same as V _{ST2} . Apply output voltage X 0.95 to V _{OUT} .		14.1	23.5	μA
Supply Current 2	I _{DD2}	Same as V _{ST2} . Apply output voltage X 1.1 to V _{OUT} .		4.0	8.1	μA
Lx Switch-On Resistance	R _{SWON}	Same as I _{DD1} . V _{Lx} =0.4V.		3.4	5.7	Ω
Lx Leak Current	I _{LXL}	No external components. V _{OUT} =V _{Lx} =10V.			1.0	μA
Oscillator Frequency	F _{OSC}	Same as I _{DD1} . Measuring of Lx waveform.	24	30	36	kHz
Maximum Duty Ratio	MAXDTY	Same as I _{DD1} . Measuring of Lx waveform.	80	87	92	%
Efficiency	EFFI			77		%
Slow-Start Time	T _{SS}		4.0	10.0	20.0	mS

Measuring conditions: Unless otherwise specified, V_{IN}=V_{OUT} X 0.6, I_{OUT}=16.5mA. See Typical Application Circuits, Fig.1.

Typical Application Circuits

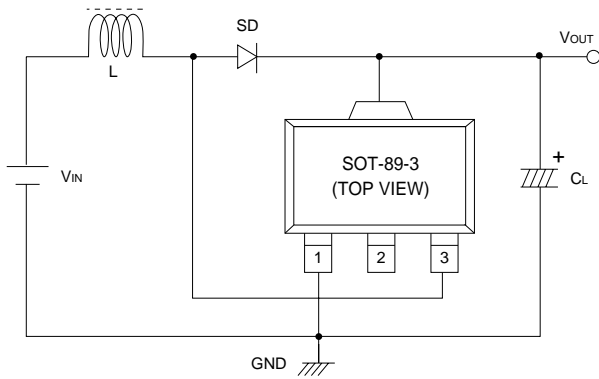

- L: 100 μ H (SUMIDA, CD-54)
- SD: MA735 (Schottky diode; MATSUSHITA)
- CL: 16V 47 μ F (Tantalum capacitor; NICHICON, F93)

Fig.1 XC6373A Application

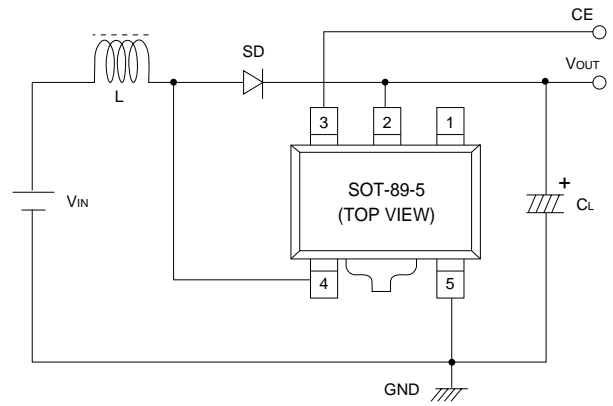

- L: 100 μ H (SUMIDA, CD-54)
- SD: MA735 (Schottky diode; MATSUSHITA)
- CL: 16V 47 μ F (Tantalum capacitor; NICHICON, F93)

Fig.3 XC6373C Application

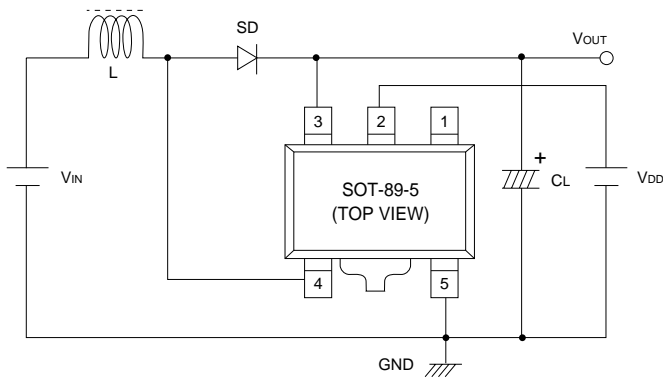

- L: 100 μ H (SUMIDA, CD-54)
- SD: MA735 (Schottky diode; MATSUSHITA)
- CL: 16V 47 μ F (Tantalum capacitor; NICHICON, F93)

Fig.5 XC6373E Application

3

Electrical Characteristics

(1) OUTPUT VOLTAGE vs. OUTPUT CURRENT

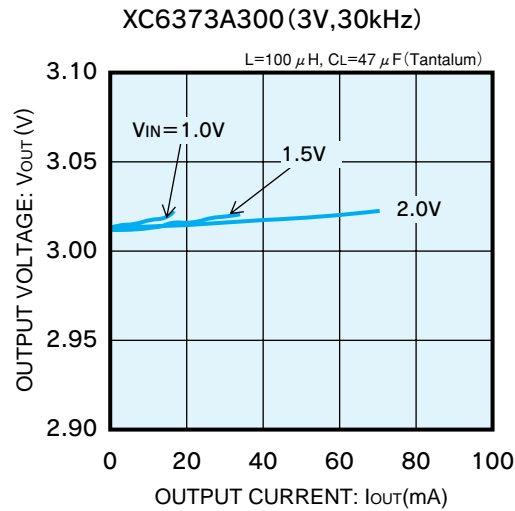

(2) EFFICIENCY vs. OUTPUT CURRENT

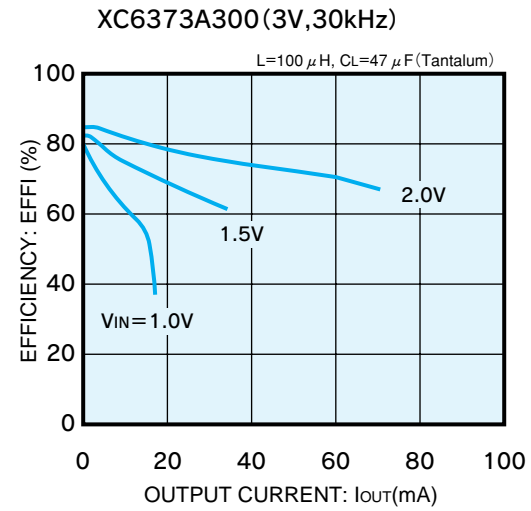

(3) NO LOAD INPUT CURRENT vs. INPUT VOLTAGE

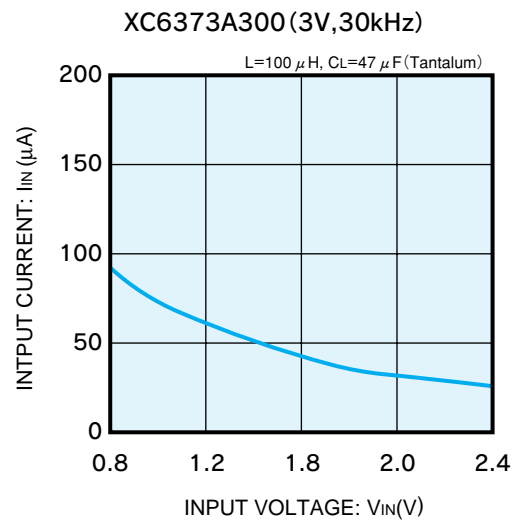

(4) RIPPLE VOLTAGE vs. OUTPUT CURRENT

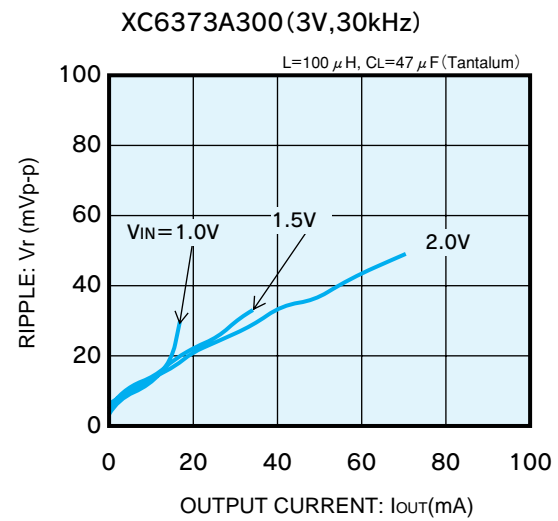

Note: Please refer to the XC6371 series application notes for more detailed information and data (www.torex.co.jp)