



### GENERAL DESCRIPTION

The ICS87004 is a highly versatile 1:4 Differential-to-LVCMOS/LVTTL Clock Generator and a member of the HiPerClockS™ family of High Performance Clock Solutions from ICS. The ICS87004 has two selectable clock inputs. The CLK0, nCLK0 and CLK1, nCLK1 pairs can accept most standard differential input levels. Internal bias on the nCLK0 and nCLK1 inputs allows the CLK0 and CLK1 inputs to accept LVCMOS/LVTTL. The ICS87004 has a fully integrated PLL and can be configured as zero delay buffer, multiplier or divider and has an input and output frequency range of 15.625MHz to 250MHz. The reference divider, feedback divider and output divider are each programmable, thereby allowing for the following output-to-input frequency ratios: 8:1, 4:1, 2:1, 1:1, 1:2, 1:4, 1:8. The external feedback allows the device to achieve “zero delay” between the input clock and the output clocks. The PLL\_SEL pin can be used to bypass the PLL for system test and debug purposes. In bypass mode, the reference clock is routed around the PLL and into the internal output dividers.

### FEATURES

- 4 LVCMOS/LVTTL outputs, 7Ω typical output impedance
- Selectable CLK0, nCLK0 or CLK1, nCLK1 clock inputs
- CLKx, nCLKx pairs can accept the following differential input levels: LVPECL, LVDS, LVHSTL, HCSL, SSTL
- Internal bias on nCLK0 and nCLK1 to support LVCMOS/LVTTL levels on CLK0 and CLK1 inputs
- Output frequency range: 15.625MHz to 250MHz
- Input frequency range: 15.625MHz to 250MHz
- VCO range: 250MHz to 500MHz
- External feedback for “zero delay” clock regeneration with configurable frequencies
- Programmable dividers allow for the following output-to-input frequency ratios: 8:1, 4:1, 2:1, 1:1, 1:2, 1:4, 1:8
- Fully integrated PLL
- Cycle-to-cycle jitter: 45ps (maximum)
- Output skew: 45ps (maximum)
- Static phase offset: 50 ± 125ps (3.3V ± 5%)
- Full 3.3V or 2.5V operating supply
- 5V tolerant inputs
- Lead-Free package fully RoHS compliant
- Industrial temperature information available upon request

### BLOCK DIAGRAM

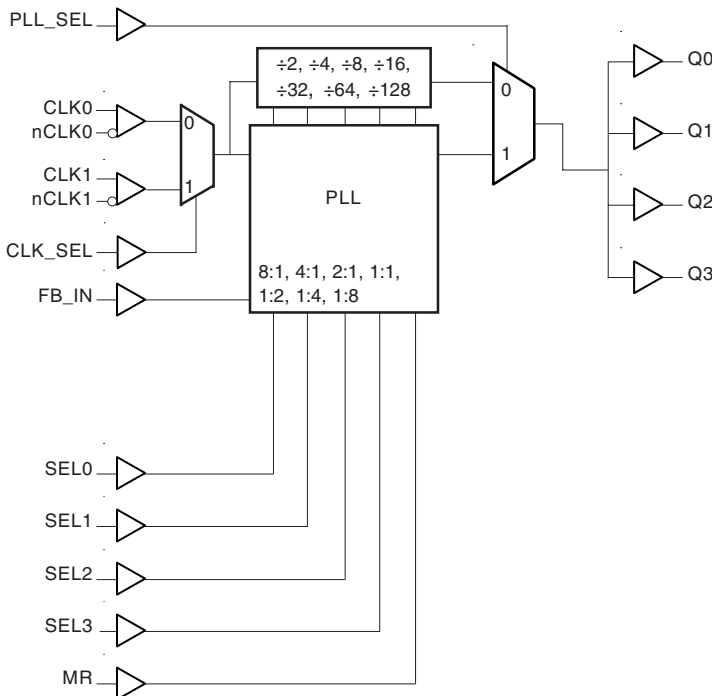

### PIN ASSIGNMENT

GND	1	24	Q1
Q0	2	23	VDDO
VDDO	3	22	Q2
SEL0	4	21	GND
SEL1	5	20	Q3
SEL2	6	19	VDDO
SEL3	7	18	MR
CLK_SEL	8	17	FB_IN
VDD	9	16	PLL_SEL
CLK0	10	15	CLK1
nCLK0	11	14	nCLK1
GND	12	13	VDDA

**24-Lead TSSOP**  
4.40mm x 7.8mm x 0.92mm  
**G Package**  
Top View



**TABLE 1. PIN DESCRIPTIONS**

Number	Name	Type		Description
1, 12, 21	GND	Power		Power supply ground.
2, 20, 22, 24	Q0, Q3, Q2, Q1	Output		Clock outputs. 7Ω typical output impedance. LVCMOS/LVTTL interface levels.
3, 19, 23	V <sub>DDO</sub>	Power		Output supply pins.
4, 5, 6, 7	SEL0, SEL1, SEL2, SEL3	Input	Pulldown	Determines output divider values in Table 3. LVCMOS/LVTTL interface levels.
8	CLK_SEL	Input	Pulldown	Clock select input. When HIGH, selects differential CLK1, nCLK1. When LOW, selects differential CLK0, nCLK0. LVCMOS/LVTTL interface levels.
9	V <sub>DD</sub>	Power		Core supply pin.
10	CLK0	Input	Pulldown	Non-inverting differential clock input.
11	nCLK0	Input	Pullup/ Pulldown	Inverting differential clock input. V <sub>DD</sub> /2 default when left floating.
13	V <sub>DDA</sub>	Power		Analog supply pin.
14	nCLK1	Input	Pullup/ Pulldown	Inverting differential clock input. V <sub>DD</sub> /2 default when left floating.
15	CLK1	Input	Pulldown	Non-inverting differential clock input.
16	PLL_SEL	Input	Pullup	Selects between the PLL and reference clock as input to the dividers. When LOW, selects the reference clock (PLL Bypass). When HIGH, selects PLL (PLL Enabled). LVCMOS/LVTTL interface levels.
17	FB_IN	Input	Pulldown	LVCMOS/LVTTL feedback input to phase detector for regenerating clocks with "zero delay". Connect to one of the outputs. LVCMOS/LVTTL interface levels.
18	MR	Input	Pulldown	Active HIGH Master Reset. When logic HIGH, the internal dividers are reset causing the outputs to go low. When logic LOW, the internal dividers and the outputs are enabled. LVCMOS/LVTTL interface levels.

NOTE: *Pullup* and *Pulldown* refer to internal input resistors. See Table 2, Pin Characteristics, for typical values.

**TABLE 2. PIN CHARACTERISTICS**

Symbol	Parameter	Test Conditions	Minimum	Typical	Maximum	Units
C <sub>IN</sub>	Input Capacitance			4		pF
R <sub>PULLUP</sub>	Input Pullup Resistor			51		kΩ
R <sub>PULLDOWN</sub>	Input Pulldown Resistor			51		kΩ
C <sub>PD</sub>	Power Dissipation Capacitance (per output)	V <sub>DD</sub> , V <sub>DDA</sub> , V <sub>DDO</sub> = 3.465V			23	pF
		V <sub>DD</sub> , V <sub>DDA</sub> , V <sub>DDO</sub> = 2.625V			17	pF
R <sub>OUT</sub>	Output Impedance		5	7	12	Ω



**TABLE 3A. PLL ENABLE FUNCTION TABLE**

Inputs					Outputs PLL_SEL = 1 PLL Enable Mode
SEL3	SEL2	SEL1	SEL0	Reference Frequency Range (MHz)	Q0:Q3
0	0	0	0	125 - 250	÷ 1
0	0	0	1	62.5 - 125	÷ 1
0	0	1	0	31.25 - 62.5	÷ 1
0	0	1	1	15.625 - 31.25	÷ 1
0	1	0	0	125 - 250	÷ 2
0	1	0	1	62.5 - 125	÷ 2
0	1	1	0	31.25 - 62.5	÷ 2
0	1	1	1	125 - 250	÷ 4
1	0	0	0	62.5 - 125	÷ 4
1	0	0	1	125 - 250	÷ 8
1	0	1	0	62.5 - 125	x 2
1	0	1	1	31.25 - 62.5	x 2
1	1	0	0	15.625 - 31.25	x 2
1	1	0	1	31.25 - 62.5	x 4
1	1	1	0	15.625 - 31.25	x 4
1	1	1	1	15.625 - 31.25	x 8

**TABLE 3B. PLL BYPASS FUNCTION TABLE**

Inputs				Outputs PLL_SEL = 0 PLL Bypass Mode
SEL3	SEL2	SEL1	SEL0	Q0:Q3
0	0	0	0	÷ 8
0	0	0	1	÷ 8
0	0	1	0	÷ 8
0	0	1	1	÷ 16
0	1	0	0	÷ 16
0	1	0	1	÷ 16
0	1	1	0	÷ 32
0	1	1	1	÷ 32
1	0	0	0	÷ 64
1	0	0	1	÷ 128
1	0	1	0	÷ 4
1	0	1	1	÷ 4
1	1	0	0	÷ 8
1	1	0	1	÷ 2
1	1	1	0	÷ 4
1	1	1	1	÷ 2



#### ABSOLUTE MAXIMUM RATINGS

Supply Voltage, $V_{DD}$	4.6V
Inputs, $V_i$	-0.5V to $V_{DD} + 0.5V$
Outputs, $V_o$	-0.5V to $V_{DDO} + 0.5V$
Package Thermal Impedance, $\theta_{JA}$	70°C/W (0 lfpm)
Storage Temperature, $T_{STG}$	-65°C to 150°C

NOTE: Stresses beyond those listed under Absolute Maximum Ratings may cause permanent damage to the device. These ratings are stress specifications only. Functional operation of product at these conditions or any conditions beyond those listed in the *DC Characteristics* or *AC Characteristics* is not implied. Exposure to absolute maximum rating conditions for extended periods may affect product reliability.

**TABLE 4A. POWER SUPPLY DC CHARACTERISTICS,  $V_{DD} = V_{DDA} = V_{DDO} = 3.3V \pm 5\%$ ,  $T_A = 0^\circ C$  TO  $70^\circ C$**

Symbol	Parameter	Test Conditions	Minimum	Typical	Maximum	Units
$V_{DD}$	Core Supply Voltage		3.135	3.3	3.465	V
$V_{DDA}$	Analog Supply Voltage		3.135	3.3	3.465	V
$V_{DDO}$	Output Supply Voltage		3.135	3.3	3.465	V
$I_{DD}$	Power Supply Current				100	mA
$I_{DDA}$	Analog Supply Current				16	mA
$I_{DDO}$	Output Supply Current				6	mA

**TABLE 4B. LVCMOS / LVTTL DC CHARACTERISTICS,  $V_{DD} = V_{DDA} = V_{DDO} = 3.3V \pm 5\%$  OR  $2.5V \pm 5\%$ ,  $T_A = 0^\circ C$  TO  $70^\circ C$**

Symbol	Parameter	Test Conditions	Minimum	Typical	Maximum	Units
$V_{IH}$	Input High Voltage	PLL_SEL, CLK_SEL, SEL0, SEL1, SEL2, SEL3, FB_IN, MR	2		$V_{DD} + 0.3$	V
$V_{IL}$	Input Low Voltage	PLL_SEL, CLK_SEL, SEL0, SEL1, SEL2, SEL3, FB_IN, MR	-0.3		0.8	V
$I_{IH}$	Input High Current	CLK_SEL, MR, FB_IN, SEL0, SEL1, SEL2, SEL3	$V_{DD} = V_{IN} = 3.465V$ $V_{DD} = V_{IN} = 2.625V$		150	$\mu A$
		PLL_SEL	$V_{DD} = V_{IN} = 3.465V$ $V_{DD} = V_{IN} = 2.625V$		5	$\mu A$
$I_{IL}$	Input Low Current	CLK_SEL, MR, FB_IN, SEL0, SEL1, SEL2, SEL3	$V_{DD} = 3.465V, V_{IN} = 0V$ $V_{DD} = 2.625V, V_{IN} = 0V$	-5		$\mu A$
		PLL_SEL	$V_{DD} = 3.465V, V_{IN} = 0V$ $V_{DD} = 2.625V, V_{IN} = 0V$	-150		$\mu A$
$V_{OH}$	Output High Voltage; NOTE 1	$V_{DDO} = 3.465V$	2.6			V
		$V_{DDO} = 2.625V$	1.8			V
$V_{OL}$	Output Low Voltage; NOTE 1	$V_{DDO} = 3.465V$ or $2.625V$			0.5	V

NOTE 1: Outputs terminated with  $50\Omega$  to  $V_{DDO}/2$ . In the Parameter Measurement Information Section, see *Output Load Test Circuit Diagrams*.



**TABLE 4C. DIFFERENTIAL DC CHARACTERISTICS,  $V_{DD} = V_{DDA} = V_{DDO} = 3.3V \pm 5\%$  OR  $2.5V \pm 5\%$ ,  $T_A = 0^\circ\text{C}$  TO  $70^\circ\text{C}$**

Symbol	Parameter	Test Conditions	Minimum	Typical	Maximum	Units
$I_{IH}$	Input High Current	CLK0, CLK1 $V_{DD} = V_{IN} = 3.465V$ , $V_{DD} = V_{IN} = 2.625V$			150	$\mu\text{A}$
		nCLK0, nCLK1 $V_{DD} = V_{IN} = 3.465V$ , $V_{DD} = V_{IN} = 2.625V$			150	$\mu\text{A}$
$I_{IL}$	Input Low Current	CLK0, CLK1 $V_{DD} = 3.465V, V_{IN} = 0V$ , $V_{DD} = 2.625V, V_{IN} = 0V$	-5			$\mu\text{A}$
		nCLK0, nCLK1 $V_{DD} = 3.465V, V_{IN} = 0V$ , $V_{DD} = 2.625V, V_{IN} = 0V$	-150			$\mu\text{A}$
$V_{PP}$	Peak-to-Peak Input Voltage		0.15		1.3	V
$V_{CMR}$	Common Mode Input Voltage; NOTE 1, 2		GND + 0.5		$V_{DD} - 0.85$	V

NOTE 1: Common mode voltage is defined as  $V_{IH}$ .

NOTE 2: For single ended applications, the maximum input voltage for CLK0, nCLK0 and CLK1, nCLK1 is  $V_{DD} + 0.3V$ .

**TABLE 4D. POWER SUPPLY DC CHARACTERISTICS,  $V_{DD} = V_{DDA} = V_{DDO} = 2.5V \pm 5\%$ ,  $T_A = 0^\circ\text{C}$  TO  $70^\circ\text{C}$**

Symbol	Parameter	Test Conditions	Minimum	Typical	Maximum	Units
$V_{DD}$	Core Supply Voltage		2.375	2.5	2.625	V
$V_{DDA}$	Analog Supply Voltage		2.375	2.5	2.625	V
$V_{DDO}$	Output Supply Voltage		2.375	2.5	2.625	V
$I_{DD}$	Power Supply Current				96	mA
$I_{DDA}$	Analog Supply Current				15	mA
$I_{DDO}$	Output Supply Current				6	mA



**TABLE 5A. AC CHARACTERISTICS,  $V_{DD} = V_{DDA} = V_{DDO} = 3.3V \pm 5\%$ ,  $T_A = 0^\circ C$  TO  $70^\circ C$**

Symbol	Parameter	Test Conditions	Minimum	Typical	Maximum	Units
$f_{MAX}$	Output Frequency		15.625		250	MHz
$t_{PD}$	Propagation Delay, NOTE 1	CLK0, nCLK0 CLK1, nCLK1 PLL_SEL = 0V $f \leq 250MHz, Q_x \div 2$	5		6	ns
$t(\theta)$	Static Phase Offset; NOTE 2, 4	CLK0, nCLK0 CLK1, nCLK1 PLL_SEL = 3.3V $f_{REF} \leq 167MHz, Q_x \div 1$	-75	50	175	ps
$t_{sk(o)}$	Output Skew; NOTE 3, 4	CLK0, nCLK0 CLK1, nCLK1 PLL_SEL = 0V		40	50	ps
$f_{jit(cc)}$	Cycle-to-Cycle Jitter; NOTE 4	$f_{OUT} > 40MHz$		30	45	ps
$t_L$	PLL Lock Time				1	ms
$t_R / t_F$	Output Rise/Fall Time	20% to 80%	400		800	ps
odc	Output Duty Cycle		40	50	60	%

NOTE 1: Measured from the differential input crossing point to the output at  $V_{DDO}/2$ .

NOTE 2: Defined as the time difference between the input reference clock and the average feedback input signal when the PLL is locked and the input reference frequency is stable.

NOTE 3: Defined as skew between outputs at the same supply voltages and with equal load conditions. Measured at  $V_{DDO}/2$ .

NOTE 4: This parameter is defined in accordance with JEDEC Standard 65.

**TABLE 5B. AC CHARACTERISTICS,  $V_{DD} = V_{DDA} = V_{DDO} = 2.5V \pm 5\%$ ,  $T_A = 0^\circ C$  TO  $70^\circ C$**

Symbol	Parameter	Test Conditions	Minimum	Typical	Maximum	Units
$f_{MAX}$	Output Frequency		15.625		250	MHz
$t_{PD}$	Propagation Delay, NOTE 1	CLK0, nCLK0 CLK1, nCLK1 PLL_SEL = 0V $f \leq 250MHz, Q_x \div 2$	5.3		6.7	ns
$t(\theta)$	Static Phase Offset; NOTE 2, 4	CLK0, nCLK0 CLK1, nCLK1 PLL_SEL = 2.5V $f_{REF} \leq 167MHz, Q_x \div 1$	-175	-25	125	ps
$t_{sk(o)}$	Output Skew; NOTE 3, 4	CLK0, nCLK0 CLK1, nCLK1 PLL_SEL = 0V		40	45	ps
$f_{jit(cc)}$	Cycle-to-Cycle Jitter; NOTE 4	$f_{OUT} > 40MHz$		35	45	ps
$t_L$	PLL Lock Time				1	ms
$t_R / t_F$	Output Rise/Fall Time	20% to 80%	400		700	ps
odc	Output Duty Cycle		44	50	56	%

NOTE 1: Measured from the differential input crossing point to the output at  $V_{DDO}/2$ .

NOTE 2: Defined as the time difference between the input reference clock and the average feedback input signal when the PLL is locked and the input reference frequency is stable.

NOTE 3: Defined as skew between outputs at the same supply voltages and with equal load conditions. Measured at  $V_{DDO}/2$ .

NOTE 4: This parameter is defined in accordance with JEDEC Standard 65.



**PARAMETER MEASUREMENT INFORMATION**

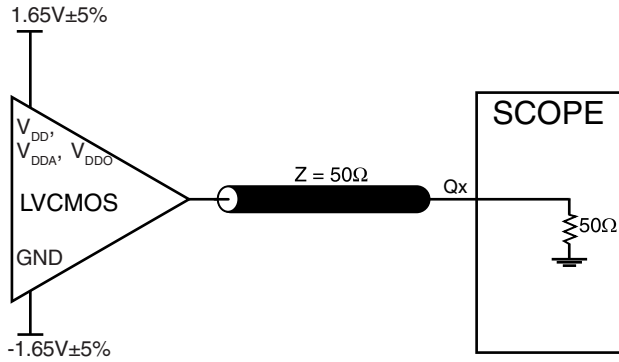

**3.3V OUTPUT LOAD AC TEST CIRCUIT**

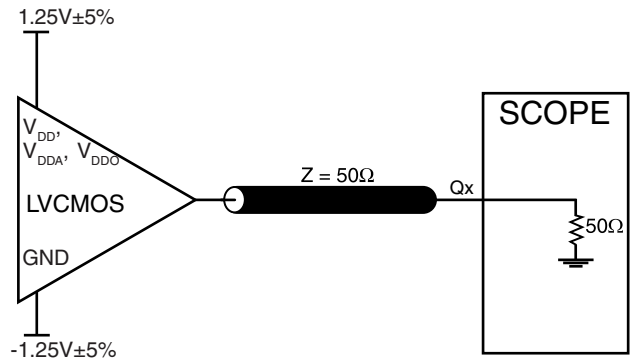

**2.5V OUTPUT LOAD AC TEST CIRCUIT**

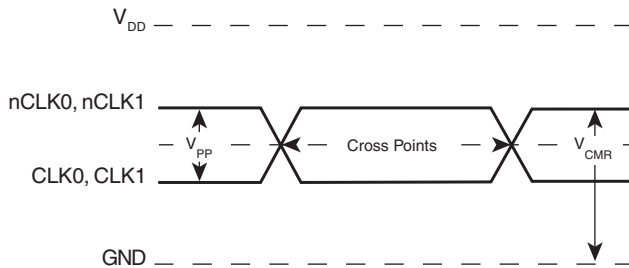

**DIFFERENTIAL INPUT LEVEL**

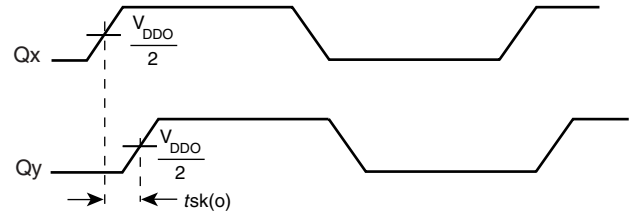

**OUTPUT SKEW**

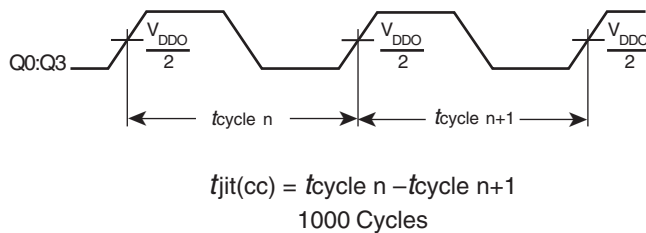

**CYCLE-TO-CYCLE JITTER**

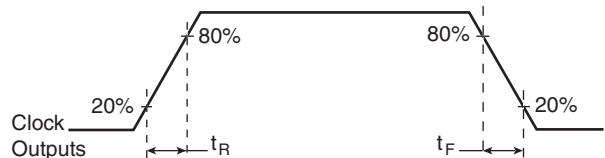

**OUTPUT RISE/FALL TIME**

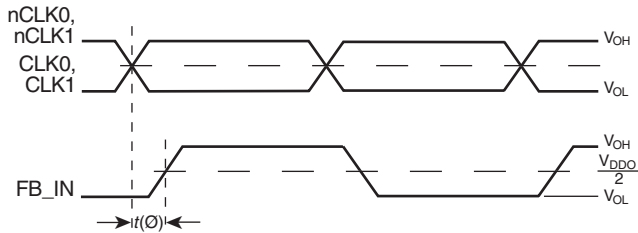
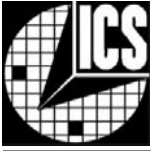

$t(\emptyset)$  mean = Static Phase Offset  
(where  $t(\emptyset)$  is any random sample, and  $t(\emptyset)$  mean is the average of the sampled cycles measured on controlled edges)

**STATIC PHASE OFFSET**

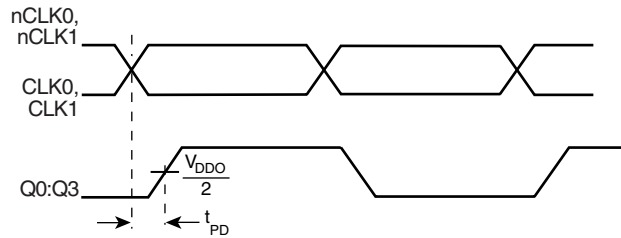

**PROPAGATION DELAY**

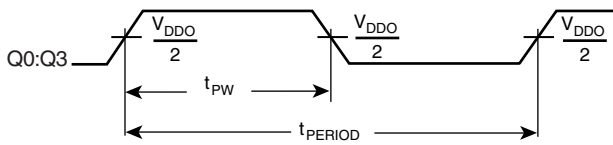

$$odc = \frac{t_{PW}}{t_{PERIOD}}$$

**OUTPUT DUTY CYCLE/PULSE WIDTH/PERIOD**





## APPLICATION INFORMATION

### POWER SUPPLY FILTERING TECHNIQUES

As in any high speed analog circuitry, the power supply pins are vulnerable to random noise. The ICS87004 provides separate power supplies to isolate any high switching noise from the outputs to the internal PLL.  $V_{DD}$ ,  $V_{DDA}$ , and  $V_{DDO}$  should be individually connected to the power supply plane through vias, and bypass capacitors should be used for each pin. To achieve optimum jitter performance, power supply isolation is required. *Figure 1* illustrates how a  $10\Omega$  resistor along with a  $10\mu\text{F}$  and a  $.01\mu\text{F}$  bypass capacitor should be connected to each  $V_{DDA}$ .

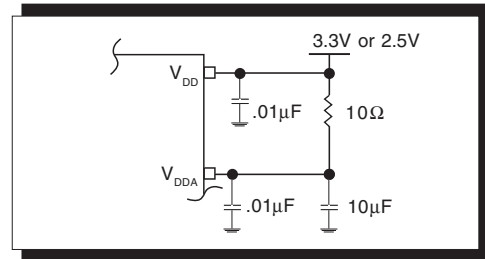

FIGURE 1. POWER SUPPLY FILTERING

### WIRING THE DIFFERENTIAL INPUT TO ACCEPT SINGLE ENDED LEVELS

*Figure 2* shows how the differential input can be wired to accept single ended levels. The reference voltage  $V_{REF} = V_{DD}/2$  is generated by the bias resistors  $R1$ ,  $R2$  and  $C1$ . This bias circuit should be located as close as possible to the input pin. The ratio

of  $R1$  and  $R2$  might need to be adjusted to position the  $V_{REF}$  in the center of the input voltage swing. For example, if the input clock swing is only 2.5V and  $V_{DD} = 3.3\text{V}$ ,  $V_{REF}$  should be 1.25V and  $R2/R1 = 0.609$ .

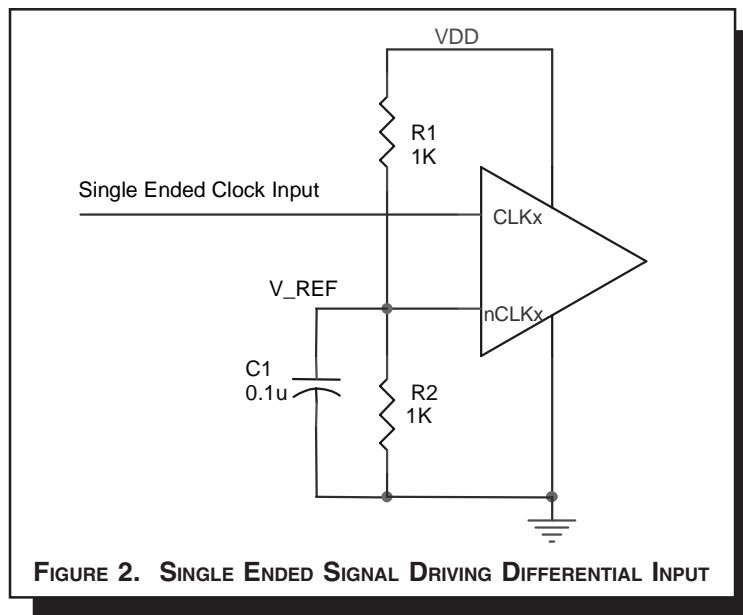

FIGURE 2. SINGLE ENDED SIGNAL DRIVING DIFFERENTIAL INPUT



### DIFFERENTIAL CLOCK INPUT INTERFACE

The CLK/nCLK accepts LVDS, LVPECL, LVHSTL, SSTL, HCSTL and other differential signals. Both  $V_{SWING}$  and  $V_{OH}$  must meet the  $V_{PP}$  and  $V_{CMR}$  input requirements. Figures 3A to 3D show interface examples for the HiPerClockS CLK/nCLK input driven by the most common driver types. The input interfaces suggested

here are examples only. Please consult with the vendor of the driver component to confirm the driver termination requirements. For example in *Figure 3A*, the input termination applies for ICS HiPerClockS LVHSTL drivers. If you are using an LVHSTL driver from another vendor, use their termination recommendation.

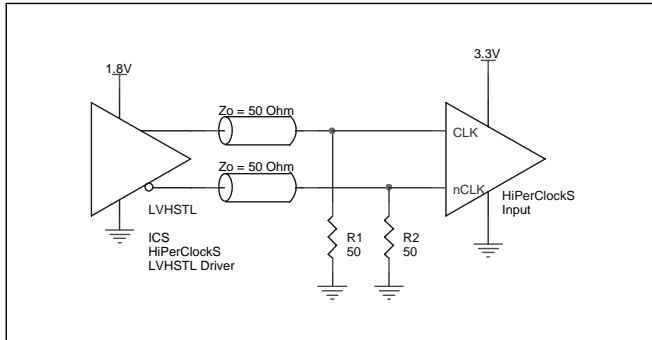

**FIGURE 3A. HiPerClockS CLK/nCLK INPUT DRIVEN BY ICS HiPerClockS LVHSTL DRIVER**

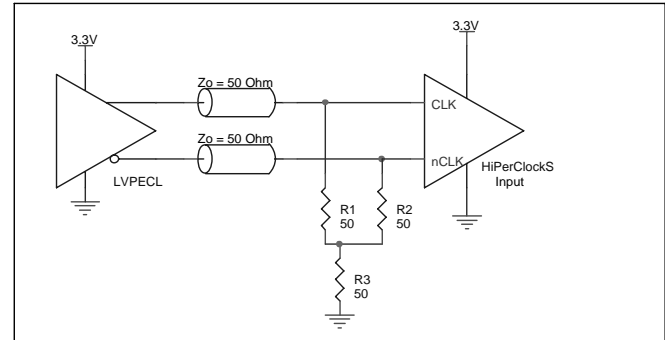

**FIGURE 3B. HiPerClockS CLK/nCLK INPUT DRIVEN BY 3.3V LVPECL DRIVER**

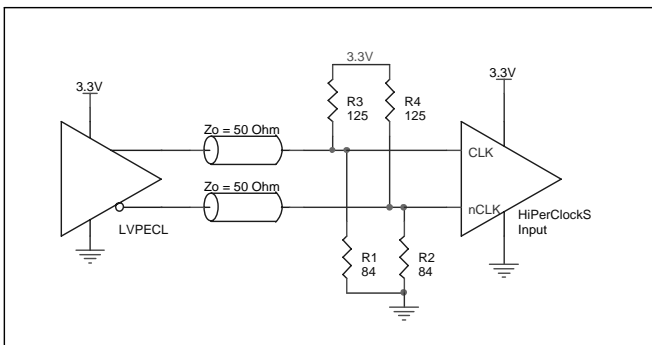

**FIGURE 3C. HiPerClockS CLK/nCLK INPUT DRIVEN BY 3.3V LVPECL DRIVER**

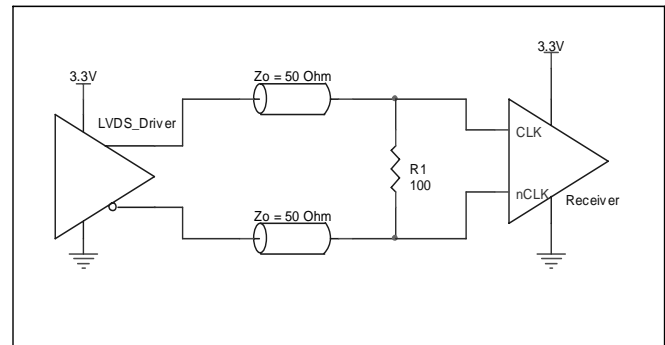

**FIGURE 3D. HiPerClockS CLK/nCLK INPUT DRIVEN BY 3.3V LVDS DRIVER**



## RELIABILITY INFORMATION

TABLE 6.  $\theta_{JA}$  vs. AIR FLOW TABLE FOR 24 LEAD TSSOP

$\theta_{JA}$ by Velocity (Linear Feet per Minute)			
	0	200	500
Multi-Layer PCB, JEDEC Standard Test Boards	70°C/W	63°C/W	60°C/W
<b>NOTE:</b> Most modern PCB designs use multi-layered boards. The data in the second row pertains to most designs.			

### TRANSISTOR COUNT

The transistor count for ICS87004 is: 2578



PACKAGE OUTLINE - G SUFFIX FOR 24 LEAD TSSOP

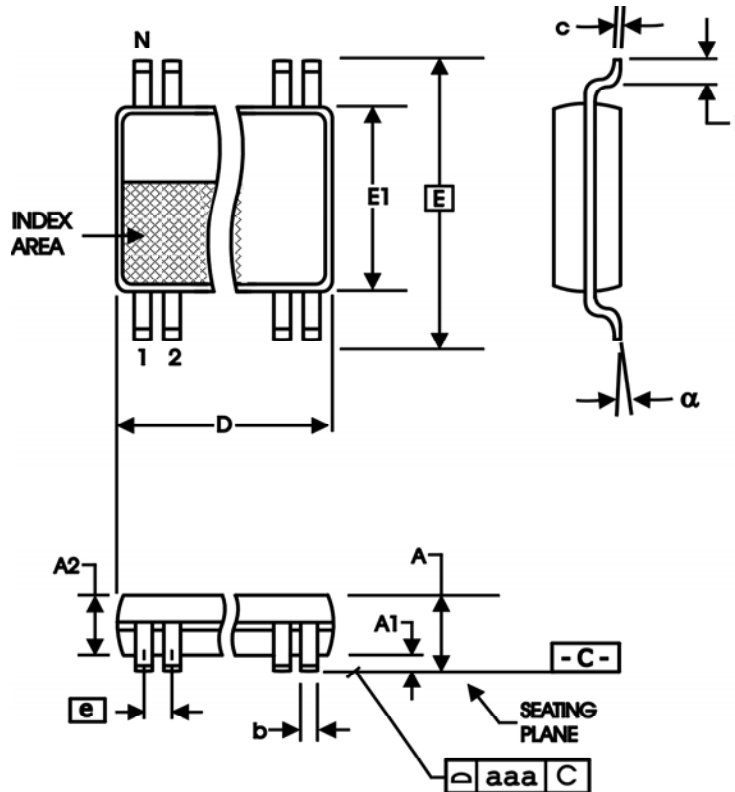

TABLE 7. PACKAGE DIMENSIONS

SYMBOL	Millimeters	
	Minimum	Maximum
N	24	
A	--	1.20
A1	0.05	0.15
A2	0.80	1.05
b	0.19	0.30
c	0.09	0.20
D	7.70	7.90
E	6.40 BASIC	
E1	4.30	4.50
e	0.65 BASIC	
L	0.45	0.75
α	0°	8°
aaa	--	0.10

Reference Document: JEDEC Publication 95, MO-153



Integrated  
Circuit  
Systems, Inc.

# ICS87004

## 1:4, DIFFERENTIAL-TO-LVCMOS/LVTTL

### ZERO DELAY CLOCK GENERATOR

**TABLE 8. ORDERING INFORMATION**

Part/Order Number	Marking	Package	Shipping Packaging	Temperature
ICS87004AG	ICS87004AG	24 Lead TSSOP	tube	0°C to 70°C
ICS87004AGT	ICS87004AG	24 Lead TSSOP	2500 tape & reel	0°C to 70°C
ICS87004AGLF	ICS87004AGLF	24 Lead "Lead Free" TSSOP	tube	0°C to 70°C
ICS87004AGLFT	ICS87004AGLF	24 Lead "Lead Free" TSSOP	2500 tape & reel	0°C to 70°C

NOTE: Parts that are ordered with an "LF" suffix to the part number are the Pb-Free configuration and are RoHS compliant.

The aforementioned trademark, HiPerClockS™ is a trademark of Integrated Circuit Systems, Inc. or its subsidiaries in the United States and/or other countries.

While the information presented herein has been checked for both accuracy and reliability, Integrated Circuit Systems, Incorporated (ICS) assumes no responsibility for either its use or for infringement of any patents or other rights of third parties, which would result from its use. No other circuits, patents, or licenses are implied. This product is intended for use in normal commercial applications. Any other applications such as those requiring extended temperature range, high reliability, or other extraordinary environmental requirements are not recommended without additional processing by ICS. ICS reserves the right to change any circuitry or specifications without notice. ICS does not authorize or warrant any ICS product for use in life support devices or critical medical instruments.



Integrated  
Circuit  
Systems, Inc.

**ICS87004**  
**1:4, DIFFERENTIAL-TO-LVCMOS/LVTTL**  
**ZERO DELAY CLOCK GENERATOR**

**REVISION HISTORY SHEET**

<b>Rev</b>	<b>Table</b>	<b>Page</b>	<b>Description of Change</b>	<b>Date</b>
A	T8	13	Ordering Information table - added "Lead-Free" part number.	6/16/04
A	T8	13	Ordering Information table - corrected "Lead-Free" part number. Added Lead-Free note.	5/17/05